



# INSTALLATION INSTRUCTIONS

Accessory  
**REAR TAILGATE DEFLECTOR**  
P/N 08F40-SCV-100

Application  
**2010 ELEMENT**

Publications No.  
**All 42687**  
Issue Date  
**SEPT 2009**

## PARTS LIST

Rear tailgate deflector

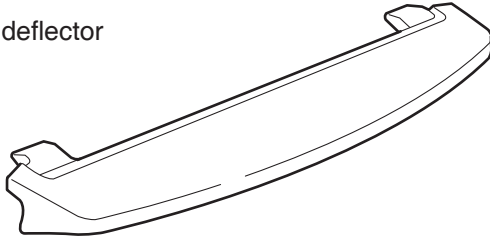

2 Cap nuts



2 Washer-bolts

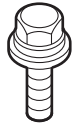

## TOOLS AND SUPPLIES REQUIRED

Eye protection (face shield, safety goggles, etc.)

Drill

3 mm and 8 mm Drill bits

10 mm Socket

Torque wrench

File

Center punch

Touch-up paint

Masking tape

## INSTALLATION

**Customer Information:** The information in this installation instruction is intended for use only by skilled technicians who have the proper tools, equipment, and training to correctly and safely add equipment to your vehicle. These procedures should not be attempted by "do-it-yourselfers."

**NOTE:** Be careful not to damage the finished surfaces of the body when installing the tailgate deflector.

1. Open the tailgate. Under the rubber protector, locate the identification marks on the upper tailgate. If necessary, remove the sealer from the tailgate in the area shown.

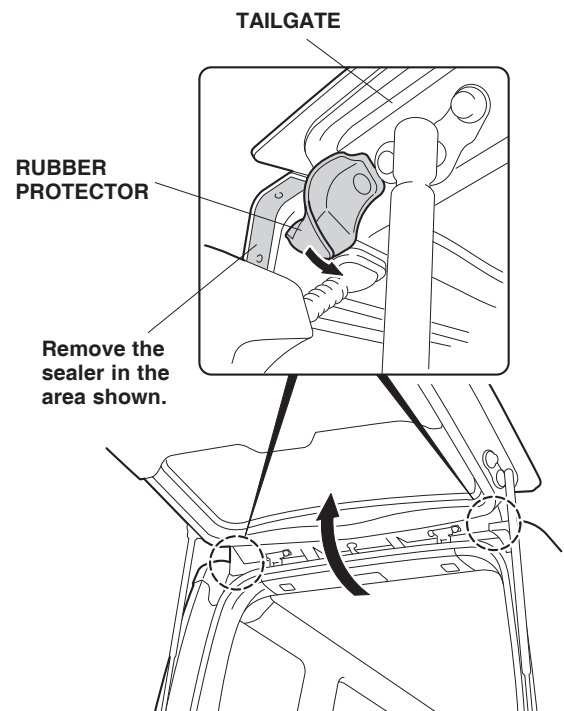

2. Center punch each identification mark.

3. While wearing eye protection, drill an 8 mm hole through the tailgate at each of the four center-punched marks:
  - To prevent damage to the roof panel, wrap masking tape around the drill bit at a point 10 mm (0.4 in.) away from the tip.
  - To prevent damage to the wire harness and the edge of the roof, move and secure the harness with tape, and apply tape to the edge of the roof panel.
  - First drill with a 3 mm bit, then finish with an 8 mm bit.
  - After drilling, remove any burrs from the edges of all holes and apply touch-up paint. Allow the touch-up paint to dry thoroughly before proceeding to the next step.

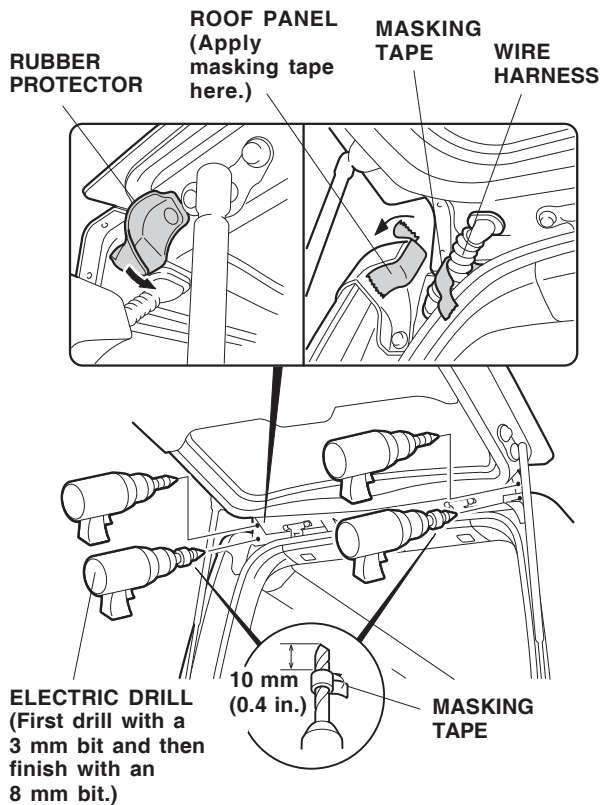

4. Position the rear tailgate deflector on the tailgate, and install the two cap nuts and two washer-bolts. Torque the washer-bolts and cap nuts to 7.0 N·m (5 to 7 lbf·ft) securely. Push the rubber protector back into position, if necessary.

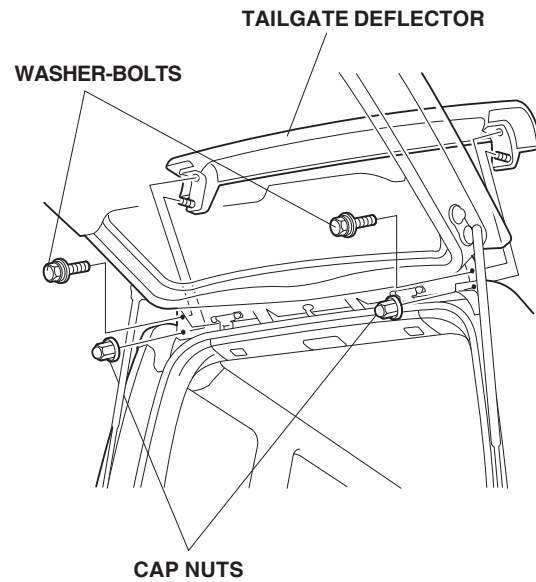

5. Remove all of the masking tape.