



INSTALLATION INSTRUCTIONS

Accessory
18" ALUMINUM WHEEL
P/N 08W18-SZA-100

Application
2010 PILOT

Publications No.
All 41672
Issue Date
MAY 2009

PARTS LIST

Aluminum wheel
(The illustration may differ from the actual wheel.)



Wheel center cap
(The illustration may differ from the actual center cap.)

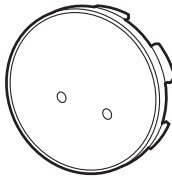

Center cap emblem

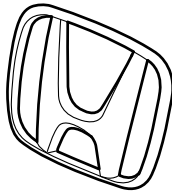

2 Push nuts



Tire pressure information label



TPMS Information
(Give this information to your customer.)

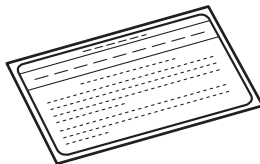

Wheel cleaning information
(Give this information to your customer.)

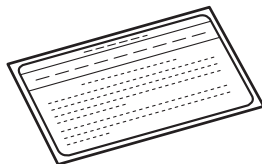

Parts for TPMS sensor assembly

Tire pressure sensor assembly

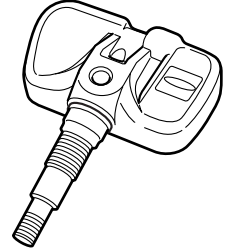

Washer



Valve nut



TOOLS AND SUPPLIES REQUIRED

- Ratchet wrench
- 11 mm Socket
- Torque wrench
- Isopropyl alcohol
- Shop towel
- HDS
- Snap-on TPMS sensor initialize tool

SPECIFICATIONS

Models not equipped with standard 18" wheels:

Rim size	18 x 7 1/2 J (offset 45)	
Tire size	245/60R18 104T	
Bolt hole PCD	120 (5 holes)	
Tire pressure	Front	220 kpa (2.3 kgf/cm ² , 32 psi)
	Rear	220 kpa (2.3 kgf/cm ² , 32 psi)

Models equipped with standard 18" wheels:

Refer to the owner's manual.

INSTALLATION

Customer Information: The information in this installation instruction is intended for use only by skilled technicians who have the proper tools, equipment, and training to correctly and safely add equipment to your vehicle. These procedures should not be attempted by “do-it-yourselfers.”

NOTE:

- This aluminum wheel is designed for use on TPMS (Tire Pressure Monitoring System) equipped vehicles.
- This aluminum wheel is equipped with the TPMS sensor. See the service manual for tire replacement procedure and TPMS sensor installation procedure.
- The illustrations of the aluminum wheels are shown for reference purposes only.
- Install the correct size tire.
- Do not overtighten the wheel nuts by placing your weight on the wrench or by using a pipe for added leverage.
Wheel nut torque: 127 N·m (95 lb·ft).
- Use a tire changer to install and remove the tires as described in the operation manual furnished with the tire changer. Do not use a tire lever to install and remove the tires as it may cause damage to the tire and aluminum wheel.
- Be careful not to damage the wheel center cap when installing the emblems.
- This center cap emblem should be installed only if the ambient air temperature is 15°C (60°F) or above.
- To allow the adhesive to cure, do not wash the vehicle for 24 hours.

1. Using isopropyl alcohol on a shop towel, clean the area where the center cap emblem will attach.

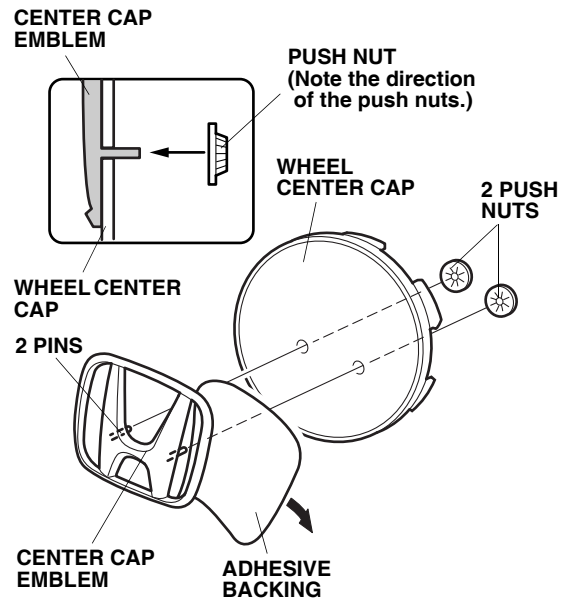

2. Remove the adhesive backing from the center cap emblem.
3. Attach the center cap emblem to the wheel center cap by aligning its pins with the holes in the wheel center cap. After attaching, hold the emblem firmly against the wheel center cap with the palm of your hand for 30 seconds.
4. Slide the two push nuts onto the two pins. Note the direction of the push nuts.

- Before installing the tire pressure sensor, clean the mating surface on the sensor and the aluminum wheel.

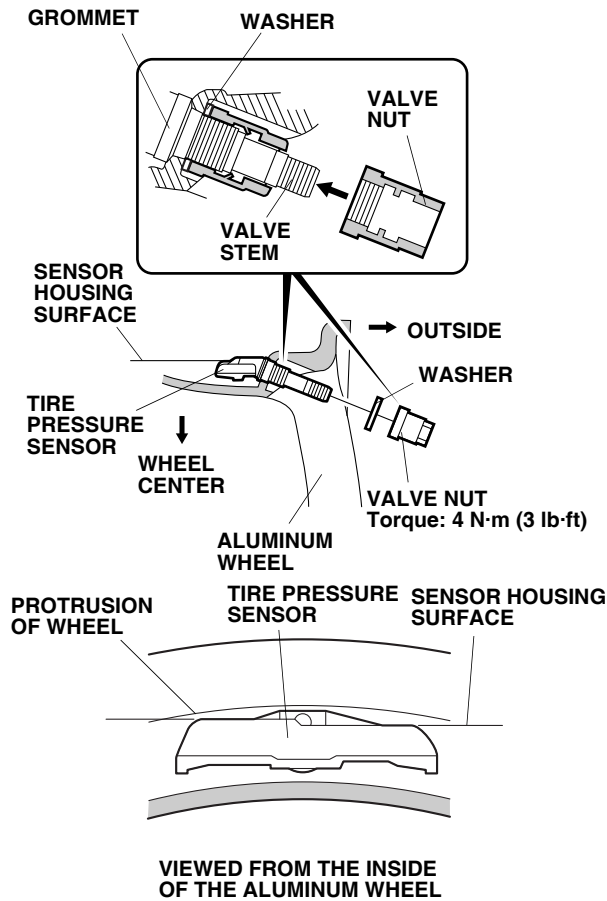

- Install the tire pressure sensor and the washer on the aluminum wheel, and tighten the valve nut finger tight. Make sure the pressure sensor is resting on the wheel.
- Torque the valve nut to 4 N·m (3 lb·ft) while holding the tire pressure sensor toward the wheel.

NOTE: Install the tire pressure sensor so that the sensor housing surface does not protrude into the bead area of the wheel to prevent the sensor housing from being caught on the bead of the tire when installing the tire.

NOTE:

- Do not reuse the valve nut that had been tightened, even one time, to the specified torque, as they are deformed inside.
 - Do not use pneumatic or electric tools on the valve nut.
 - Tightening the nut above the specified torque can damage the grommet.
- Install the tires according to the instructions in the service manual.
 - Install the wheels on the vehicle and torque the wheel nuts to 127 N·m (95 lbf·ft).

MEMORIZING THE TIRE PRESSURE SENSOR ID

- Using the HDS and Snap-on TPMS sensor initializer tool, memorize the tire pressure sensor ID according to the instructions in the service manual (Memorizing the Tire Pressure Sensor ID).

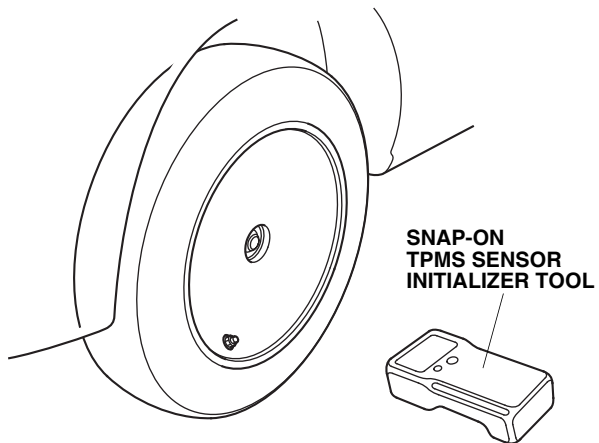
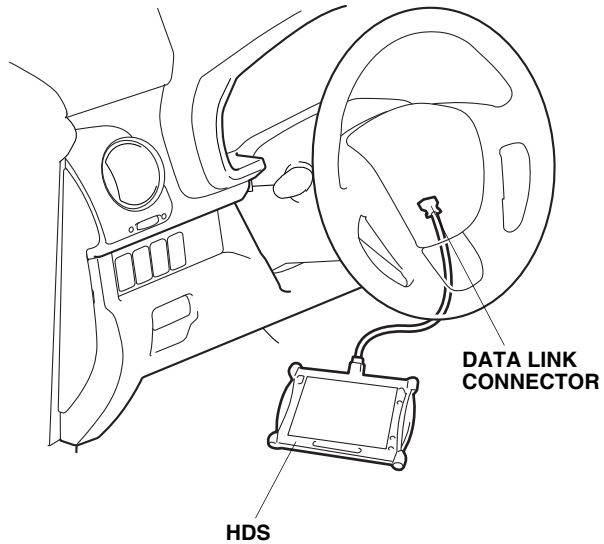

- Open the driver's door. Using isopropyl alcohol, thoroughly clean the area where the new tire pressure information label will attach. Remove the adhesive backing from the label, and apply it over the standard tire information label as shown.

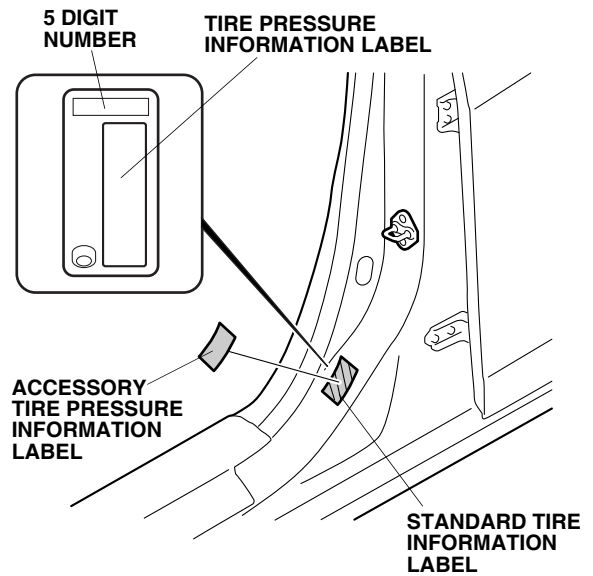

- Insert the Supplemental Information page included in this kit into the owner's manual.