



# INSTALLATION INSTRUCTIONS

Accessory  
**BUMPER TRIM**  
P/N 08F23-SJC-100A

Application  
**2010 RIDGELINE**

Publications No.  
**All 42128-45254**

Issue Date  
**OCT 2010**

## PARTS LIST

Left front bumper trim



Right front bumper trim



Left rear bumper trim

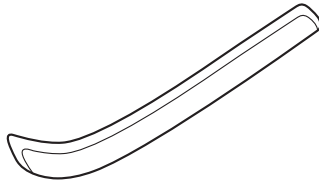

Right rear bumper trim

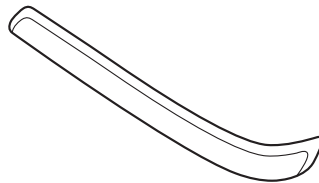

10 Brackets

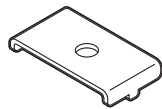

10 Self-tapping screws



## TOOL AND SUPPLIES REQUIRED

Phillips screwdriver

Flat-tip screwdriver

Ratchet

Socket

Torque wrench

Pliers

Drill

3 mm Drill bit

30 mm Hole saw

Pushpin

Plastic trim tool  
(T/N SILTRIMTL10)

Utility Knife

File

Shop towel

Masking tape

Eye protection (face shield, safety goggles, etc.)

Isopropyl alcohol

Scale

Blanket

## Illustration of the Bumper Trim on the Vehicle

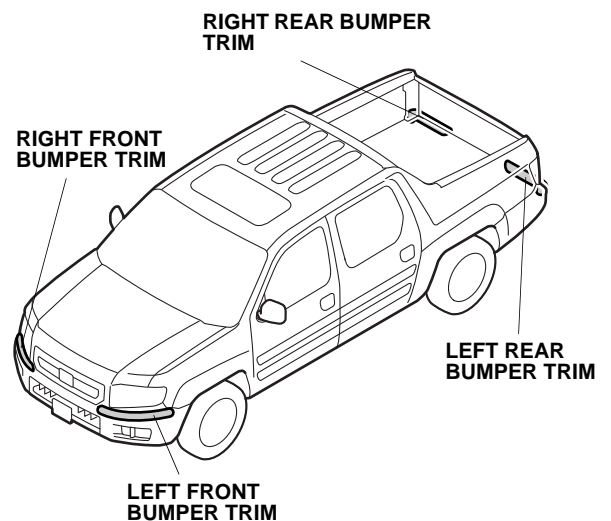

## INSTALLATION

**Customer Information:** The information in this installation instruction is intended for use only by skilled technicians who have the proper tools, equipment, and training to correctly and safely add equipment to your vehicle. These procedures should not be attempted by “do-it-yourselfers.”

### NOTE:

- Do not damage the body paint finish when removing and installing the bumper trim.
- This bumper trim kit should be installed only if the ambient air temperature is 15°C (60°F) or above.
- To allow the adhesive to cure, do not wash the vehicle for 24 hours. Please advise the customer.

### Installing the Front Bumper Trim

1. Remove the air intake duct and the front bulkhead cover (12 clips).

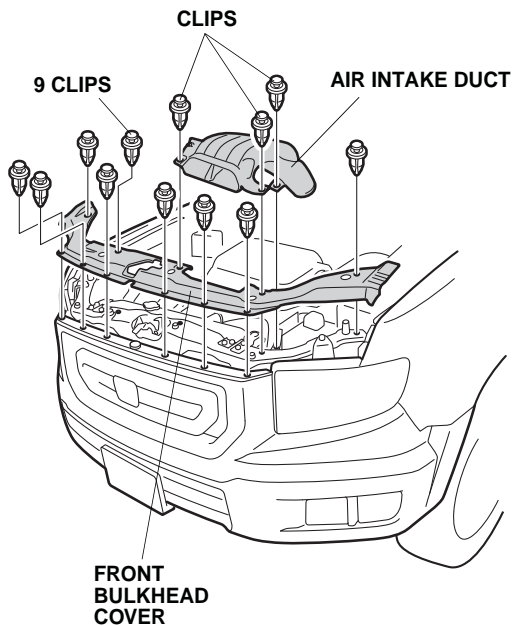

2. Remove the front bumper (1 clip, 4 bolts, 2 short step bolts, and 4 self-tapping screws). Have an assistant help you when removing and installing the front bumper. If the vehicle is equipped with fog lights, unplug the fog light connectors. Place the front bumper on a blanket.

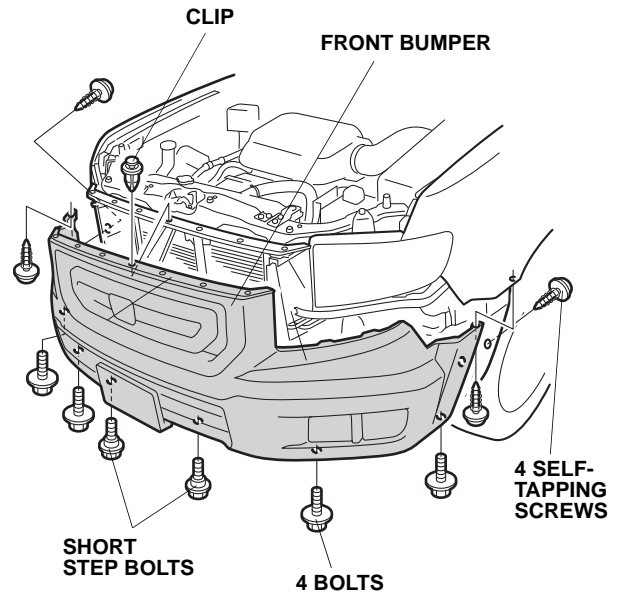

3. **With accessory fog lights** - Remove the left fog light (three self-tapping screws). Remove the right fog light.

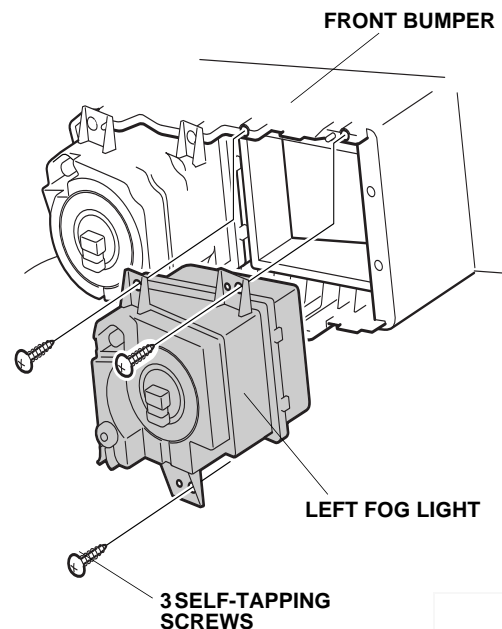

4. **Without accessory fog lights** - Remove the left cover from the front bumper (three retaining tabs). Remove the right cover.

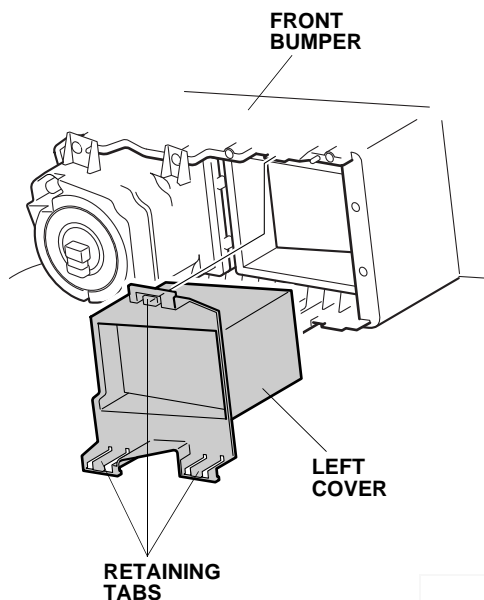

5. Remove the vehicle left DRL assembly (three self-tapping screws). Remove the right DRL assembly.

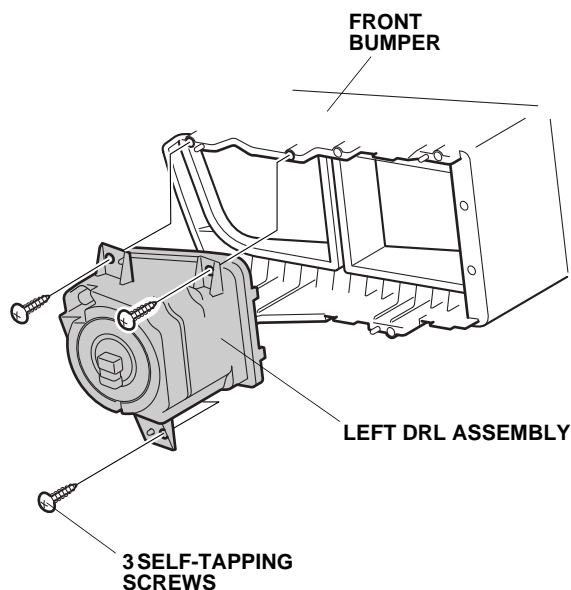

6. Using a pushpin, locate and pierce three scribe marks on the inside of the front bumper.

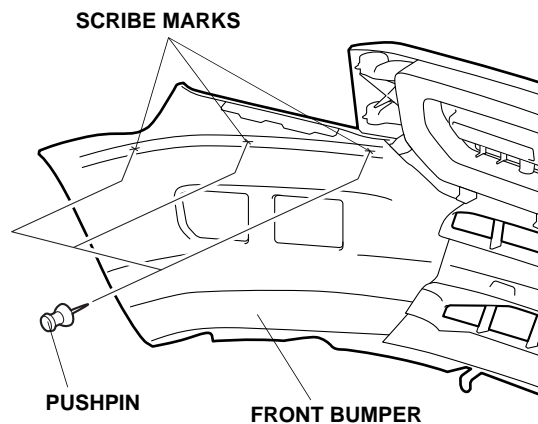

7. While wearing eye protection, drill 3 mm holes at the three marks made in step 6, then enlarge the holes with a 30 mm hole saw. Remove any burrs.

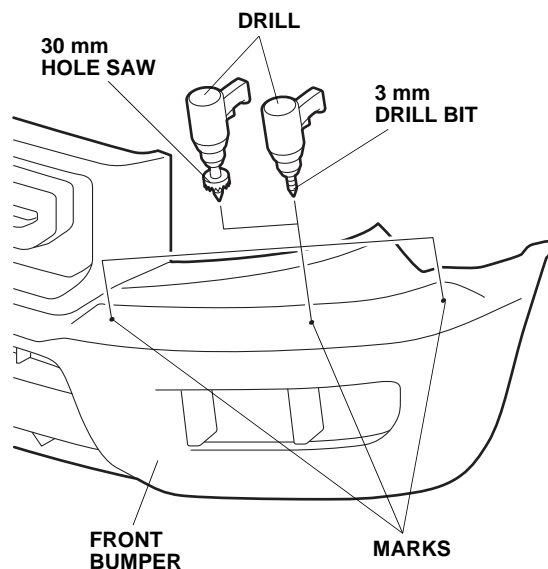

- Using isopropyl alcohol on a shop towel, thoroughly clean the area where the left front bumper trim will attach.

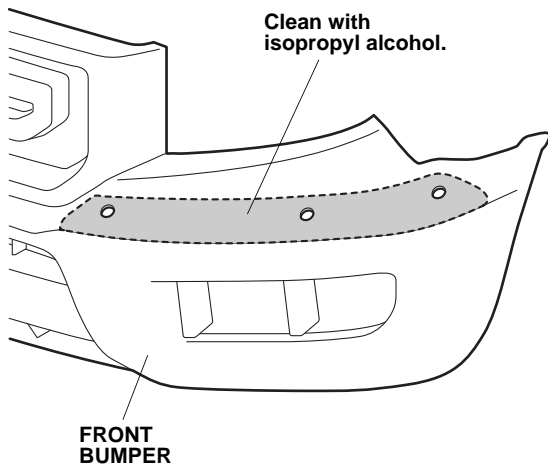

- Attach pieces of masking tape to the ends of the adhesive backings on the left front bumper trim. Peel the adhesive backings partway and attach them to the front surface of the left front bumper trim.

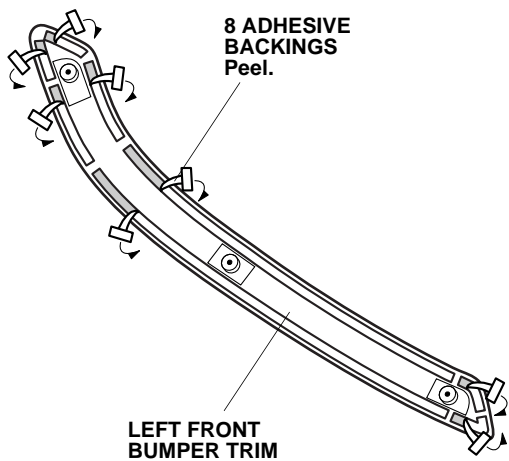

- Align the left front bumper trim to the front bumper and loosely secure it with three brackets and three self-tapping screws.

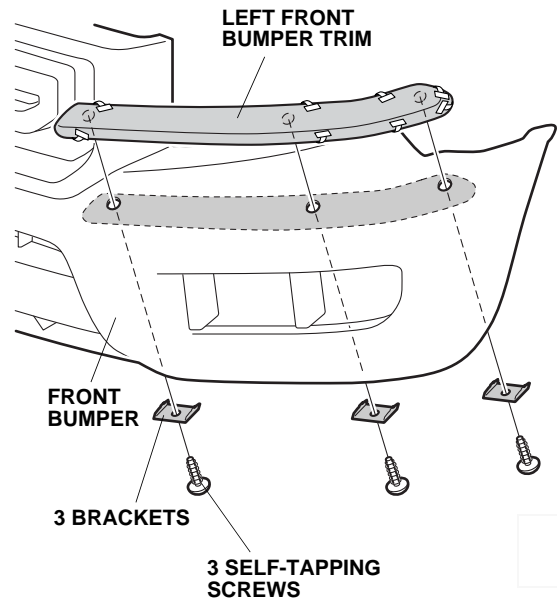

- While applying light pressure against the left front bumper trim, carefully remove the taped adhesive backings.

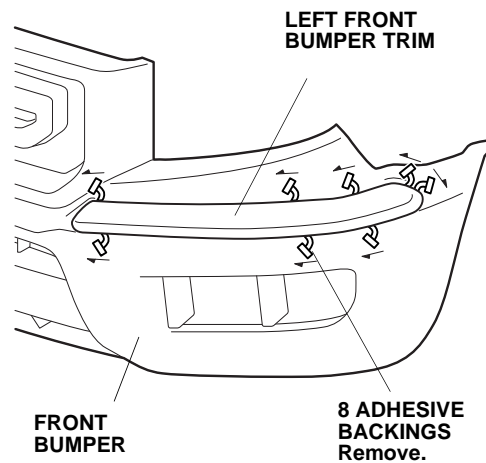

- Using the palm of your hand, firmly press the left front bumper trim against the front bumper.

- Using a pair of pliers, hold the brackets. Torque the self-tapping screws to 1.5 N·m (1.1 lbf·ft).

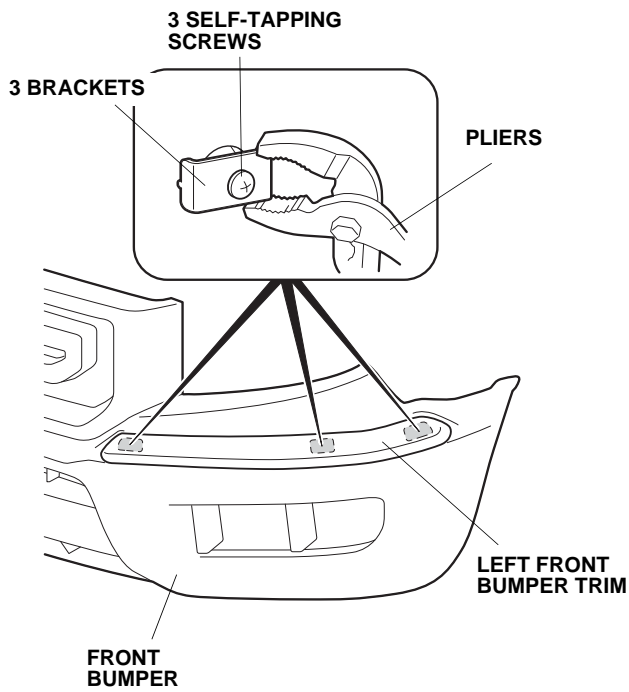

- Repeat steps 6 through 13 on the right side of the bumper.
- Reinstall all removed parts.

### Installing the Rear Bumper Trim

- Open the tailgate.
- Remove the left taillight (two bolts, two clips, release the vehicle connectors from the vehicle panel, and unplug the vehicle connector). Remove the right taillight.

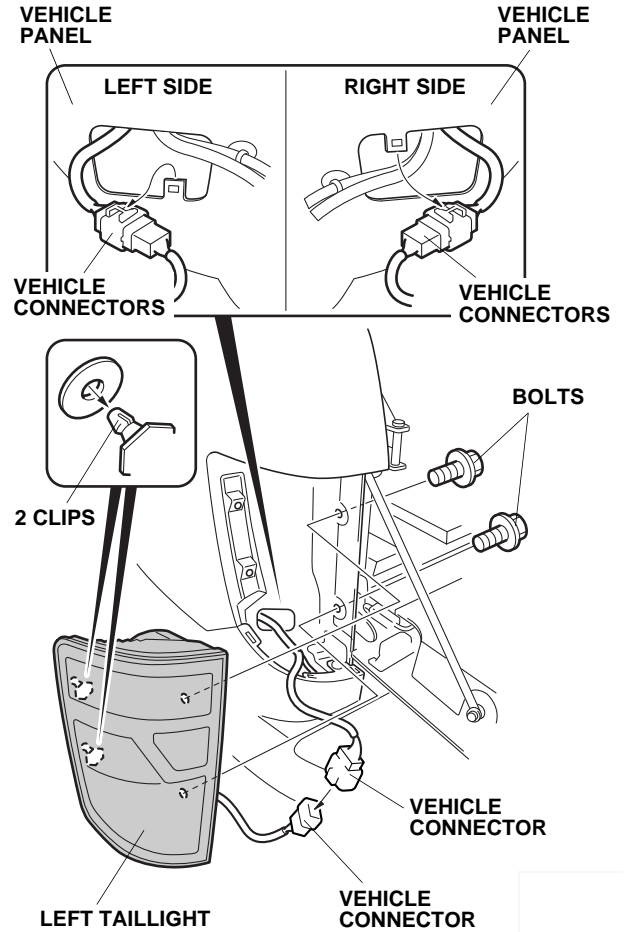

- Remove the right license plate light (three retaining tabs and unplug the vehicle connector). Remove the left license plate light.

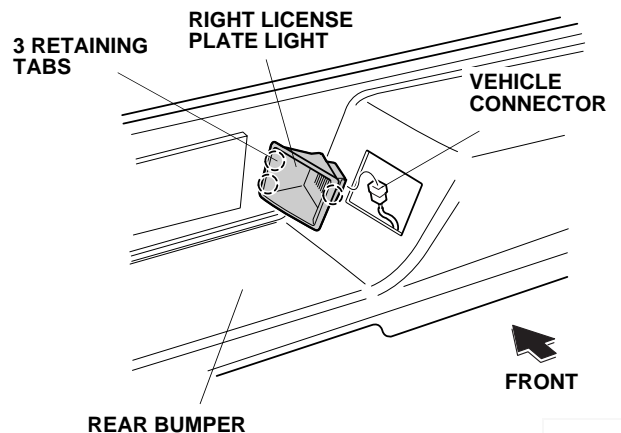

19. Remove the license plate from the rear bumper (two bolts).

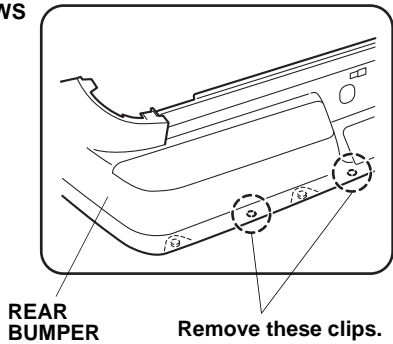
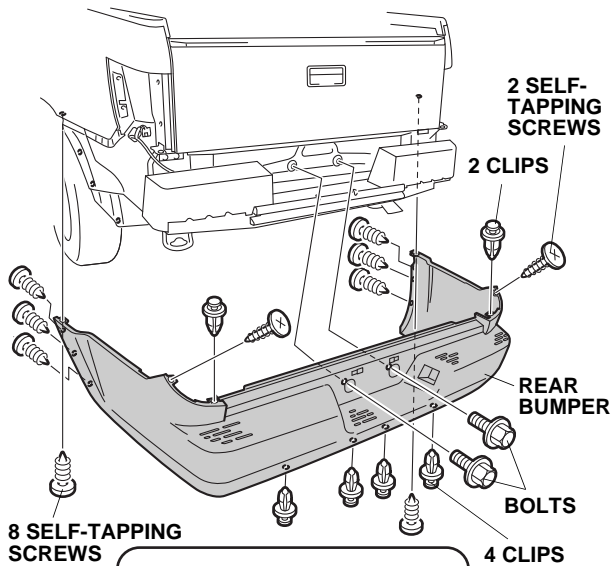
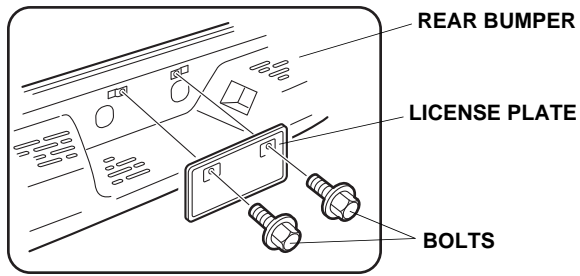

20. Remove the rear bumper (two bolts, ten self-tapping screws, and six clips). Have an assistant help you when removing and installing the rear bumper. Place the rear bumper on a blanket.

21. Using a pushpin, locate and pierce two scribe marks on the inside of the rear bumper. Make sure to pierce the correct scribe marks.

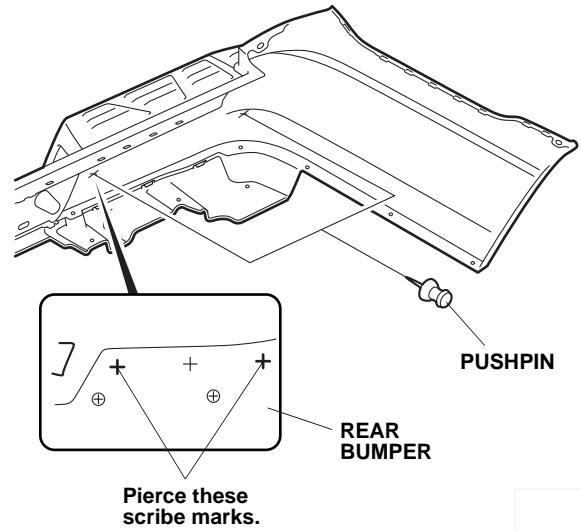

22. While wearing eye protection, drill 3 mm holes at the two marks made in step 21, then enlarge the holes with a 30 mm hole saw. Remove any burrs.

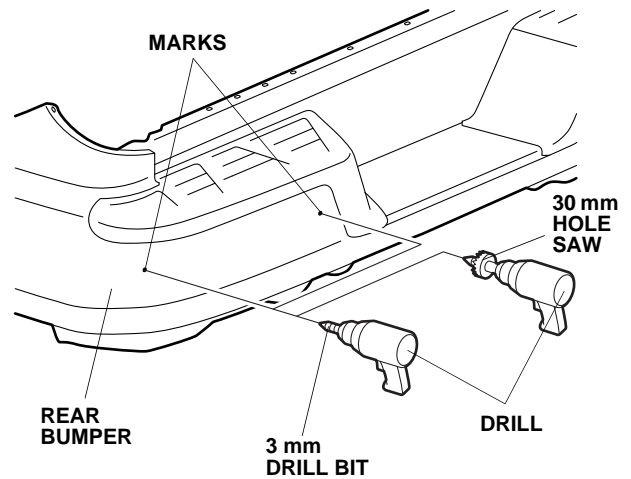

23. Using isopropyl alcohol on a shop towel, thoroughly clean the area where the left rear bumper trim will attach.

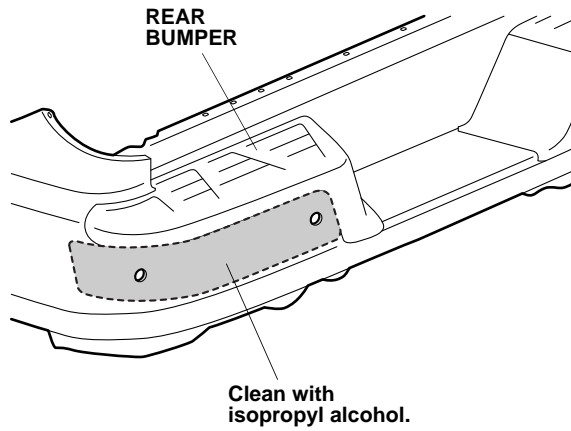

24. Attach pieces of masking tape to the ends of the adhesive backings on the left rear bumper trim. Peel the adhesive backings partway and attach them to the front surface of the left rear bumper trim.

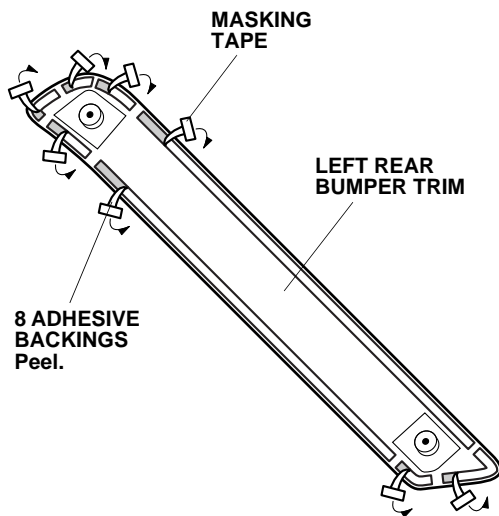

25. Align the left rear bumper trim to the rear bumper and loosely secure it with two brackets and two self-tapping screws.

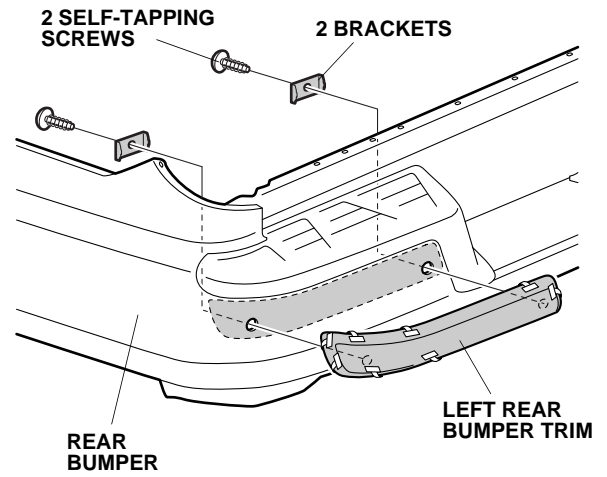

26. While applying light pressure against the left rear bumper trim, carefully remove the taped adhesive backings.

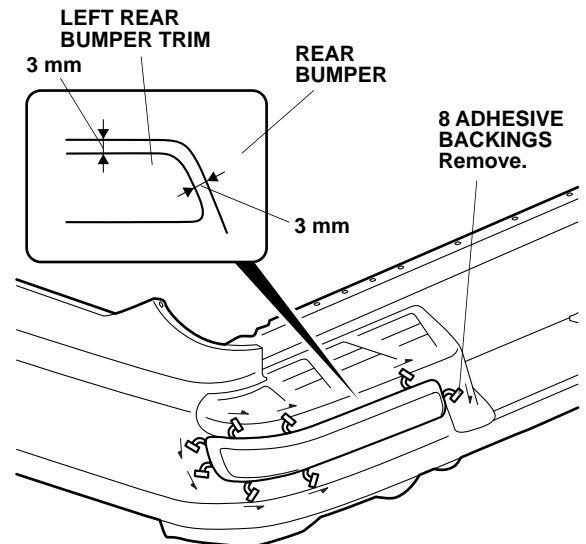

27. Using the palm of your hand, firmly press the left rear bumper trim against the bumper.

28. Using a pair of pliers, hold the brackets. Torque the self-tapping screws to 1.5 N·m (1.1 lbf·ft).

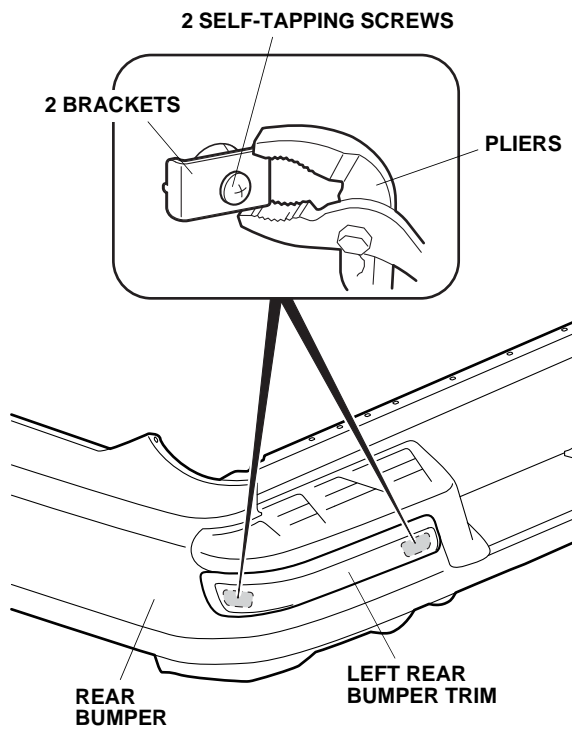

29. Repeat steps 21 through 28 on the right side of the bumper.
30. Reinstall all removed parts.