



INSTALLATION INSTRUCTIONS

Accessory

KAYAK ATTACHMENT
P/N 08L09-TA1-100

Application

2010 RIDGELINE

Publications No.

All 42142

Issue Date

AUG 2009

Put this information in the glove box with the vehicle owner's manual.

PARTS LIST

2 Saddles

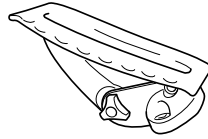

2 Hydro-glide assemblies

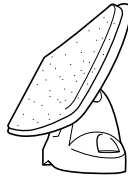

4 Brackets

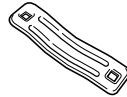

8 Bolts

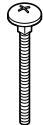

8 Knobs



2 Straps with buckle

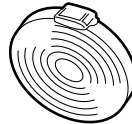

2 Buckle covers



2 Attachment straps



2 Ratchet hooks



2 Hooks



2 Pieces of rope

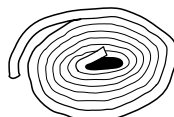

INSTALLATION

NOTE: Be careful not to damage the finished surfaces of the body when installing the kayak attachment.

1. Position the two saddles on the front crossbar. Loosely install the saddles using one bracket, two bolts, and two knobs for each saddle. The distance between the two assemblies should be the same width as the kayak.

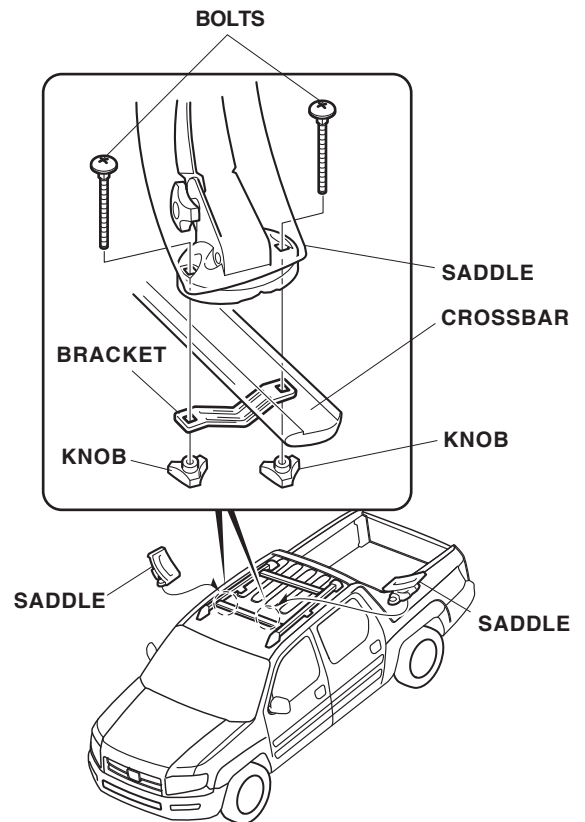

- Position the two hydro-glide assemblies on the rear crossbar. Loosely install the hydro-glide assemblies using one bracket, two bolts, and two knobs for each assembly. The distance between the two assemblies should be the same width as the kayak.

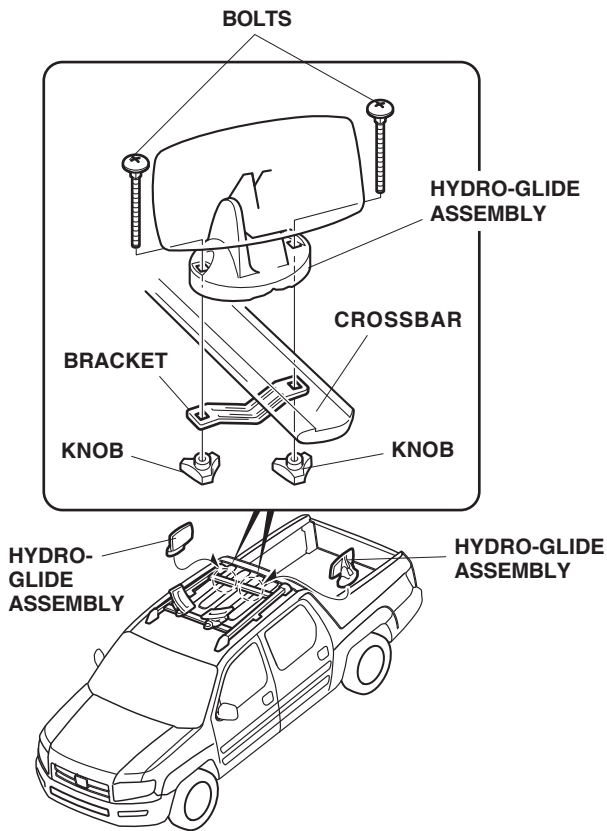

- Rest the front of the kayak on the hydro-glide assemblies. Standing behind or alongside the kayak, lift up the rear end portion of the kayak and push it forward, sliding on the hydro-glide assemblies and saddles. Make sure the kayak reaches the front saddles before you lower it.

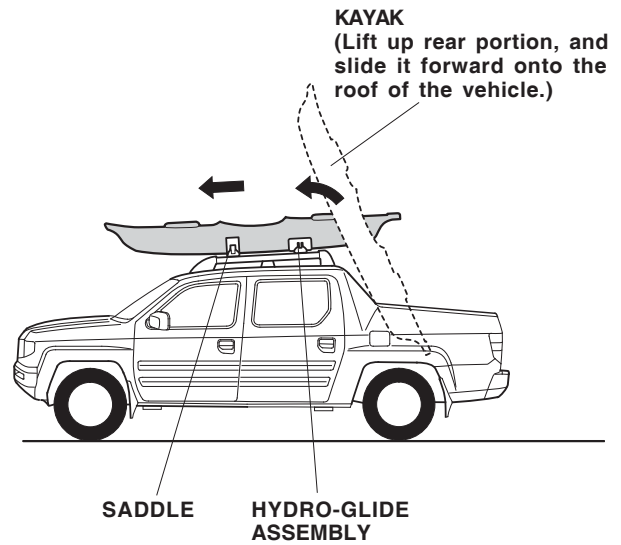

- Adjust the distance of the saddles and hydro-glide assemblies to the same width as the kayak, then secure the saddle and the hydro-glide assemblies by tightening the knobs you installed in steps 1 and 2.

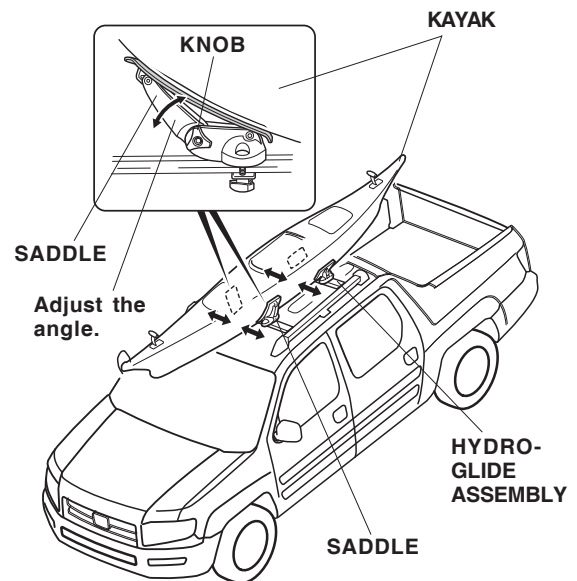

- Slide the kayak forward or backward until it's level with the roof. If necessary, loosen the knob on each saddle and adjust the saddle angle to fit snugly against the kayak. Tighten each knob securely.

- Route each strap with buckle through the buckle cover with the ribbed end facing up.

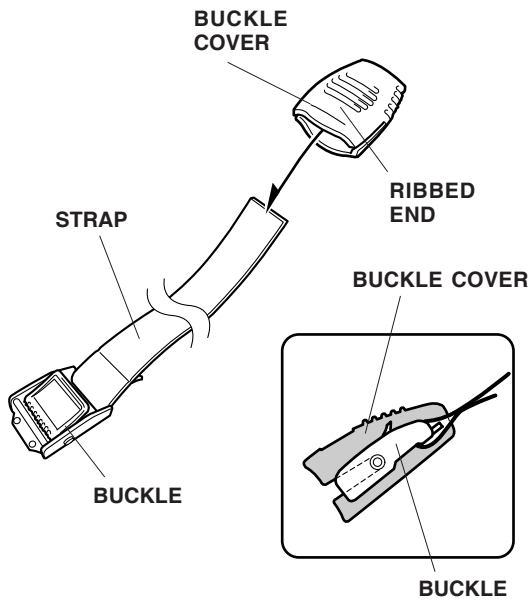

- Route the strap under the front crossbars, and around the kayak as shown. Slide the buckle cover away from the buckle, route the strap through the buckle, and tighten the strap. Slide the buckle cover back over the buckle.

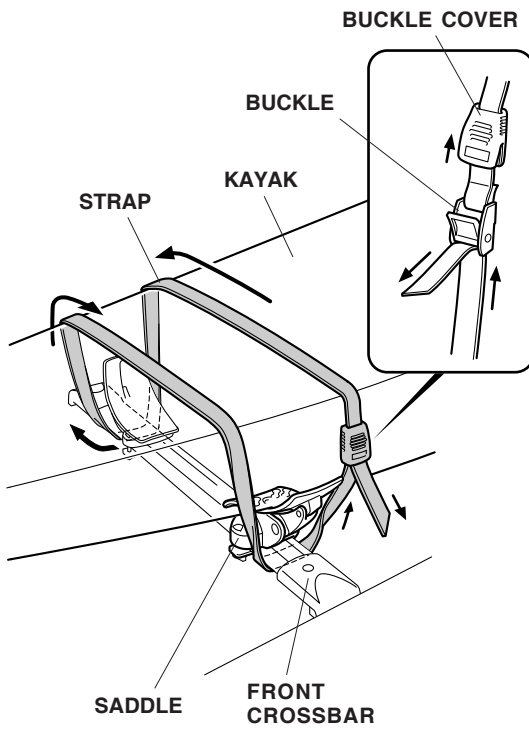

- Route the strap under the rear crossbars, and around the kayak as shown. Slide the buckle cover away from the buckle, route the strap through the buckle, and tighten the strap. Slide the buckle cover back over the buckle.

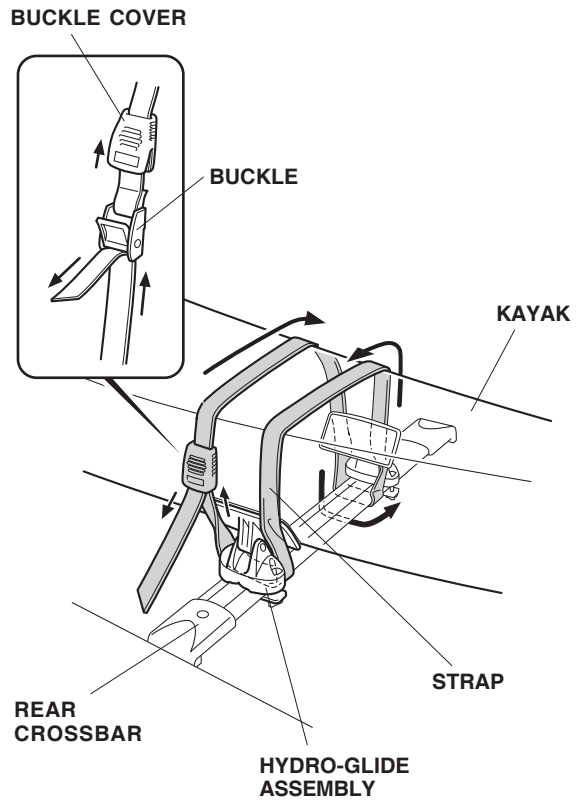

- Attach one piece of rope to the end of each hook. Tie a knot in the rope to secure the rope to the hook.

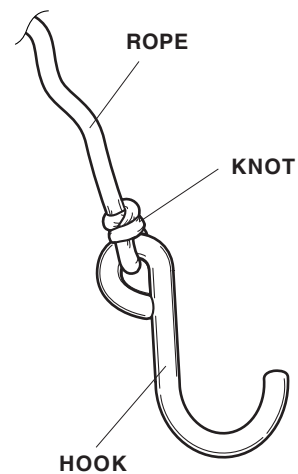

- Route the other end of the rope through the bottom of a ratchet hook in the direction shown, and turn the spool until the rope end comes out of the ratchet.

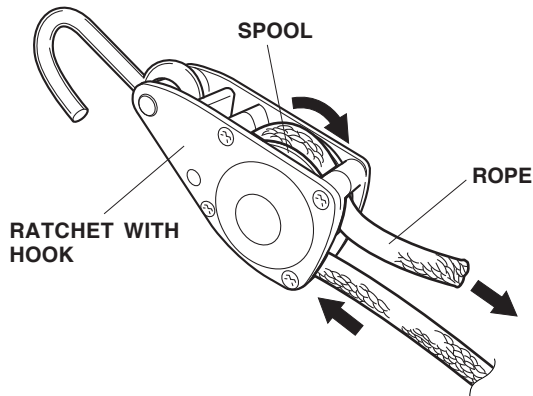

- Wrap the attachment straps around the handles at the front and at the rear of the kayak.

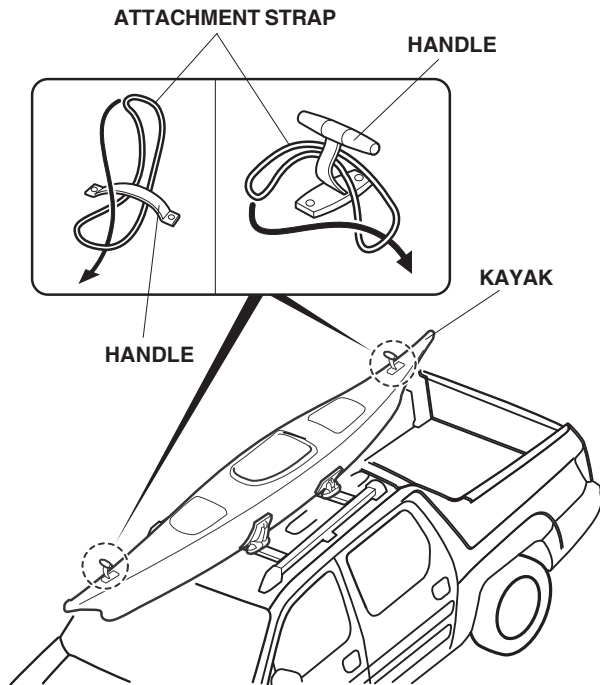

- Attach one ratchet hook to the front attachment strap and one ratchet hook to the rear attachment strap. Attach the front hook to the front bumper beam or to the tow hook. Attach the rear hook to the rear tie-down anchors in the bed. Secure the kayak to the vehicle by pulling the rope through the ratchet hooks.

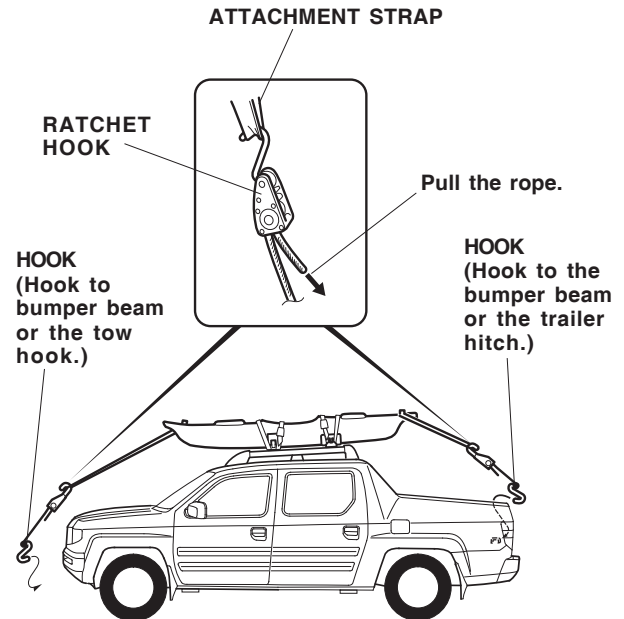

- To loosen the rope, push up on the ratchet strap lever, then pull the rope.

