

**PARTS LIST**

Front lower trim

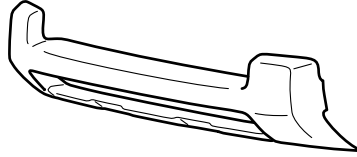

8 Flange nuts



10 Spring nuts



18 Washer bolts



Clip

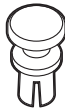

2 Collars

**TOOL AND SUPPLIES REQUIRED**

Phillips screwdriver

Flat-tip screwdriver

Ratchet

Pliers

Drill

3 mm, 6 mm, 8 mm, and 9 mm Drill bits

14 mm Hole saw

Clip remover

File

Shop towel

Eye protection (face shield, safety goggles, etc.)

Isopropyl alcohol

Utility knife

Pushpin

Masking tape

Blanket

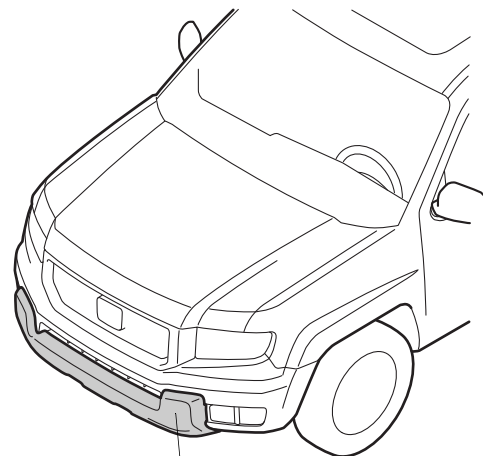
***Illustration of the Front Lower Trim on the Vehicle*****FRONT LOWER TRIM**

## INSTALLATION

**Customer Information:** The information in this installation instruction is intended for use only by skilled technicians who have the proper tools, equipment, and training to correctly and safely add equipment to your vehicle. These procedures should not be attempted by “do-it-yourselfers.”

### NOTE:

- Do not damage the body paint finish when removing and installing the bumper trim.
  - This front lower trim kit should only be installed if the ambient air temperature is 15°C (60°F) or above.
  - To allow the adhesive to cure, do not wash the vehicle for 24 hours. Please advise the customer.
1. Remove the air intake duct and the front bulkhead cover (twelve clips).

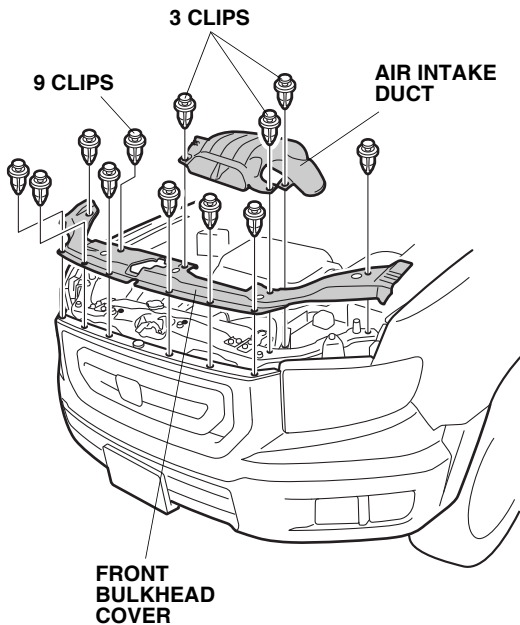

2. Remove the front bumper (one clip, four bolts, two short step bolts and four self-tapping screws). Have an assistant help you when removing the front bumper. If the vehicle is equipped with fog lights, unplug the fog light connectors. Place the front bumper on a blanket after removal.

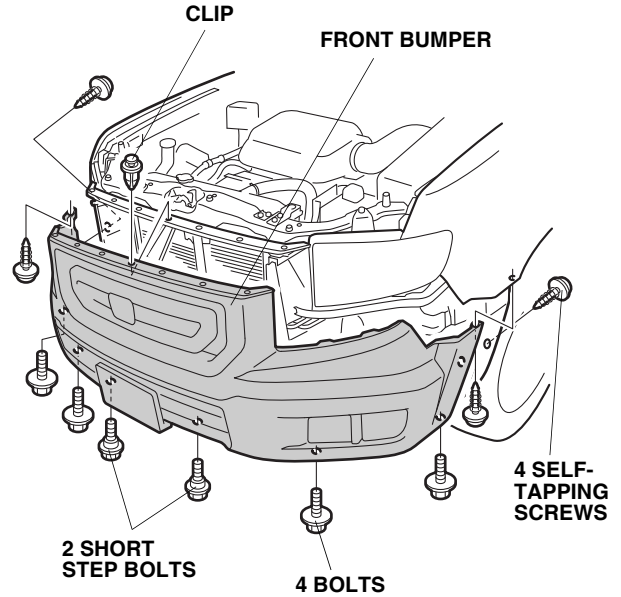

- Using a pushpin, locate and pierce 16 holes at the scribe marks from the inside of the front bumper. Make sure to pierce the correct scribe mark.

Do not pierce this scribe mark.

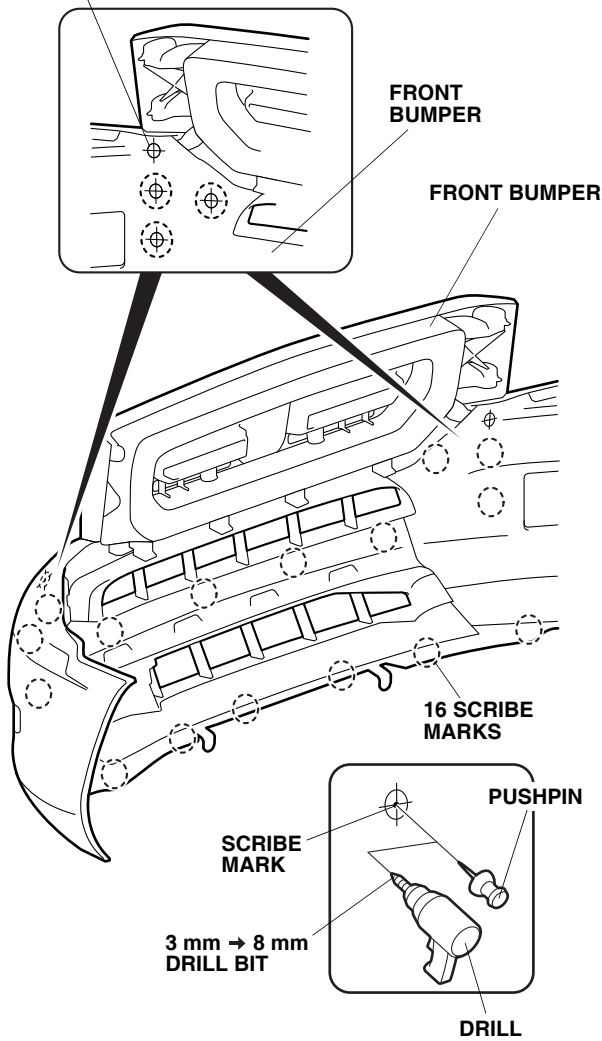

- While wearing eye protection, drill a 3 mm hole at the 16 pierced holes made in step 3 and widen the hole with 8 mm drill bit from the outside of the front bumper. Remove any burrs.

If the vehicle is equipped with a front license frame, go to step 5; if not, go to step 11.

- Remove the front license frame from the front bumper (two self-tapping screws).

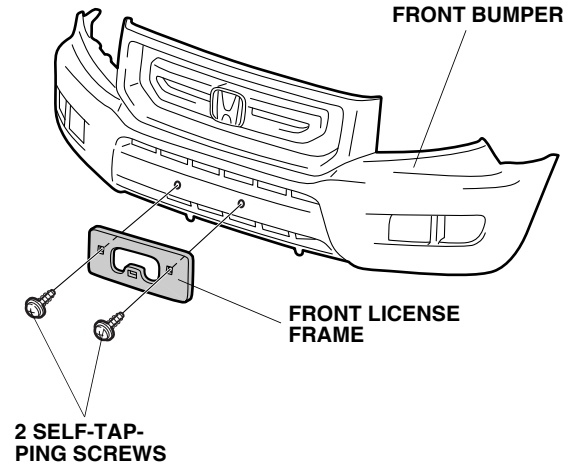

- Using a pushpin, locate and pierce three holes at the scribe marks from the inside of the front lower trim.

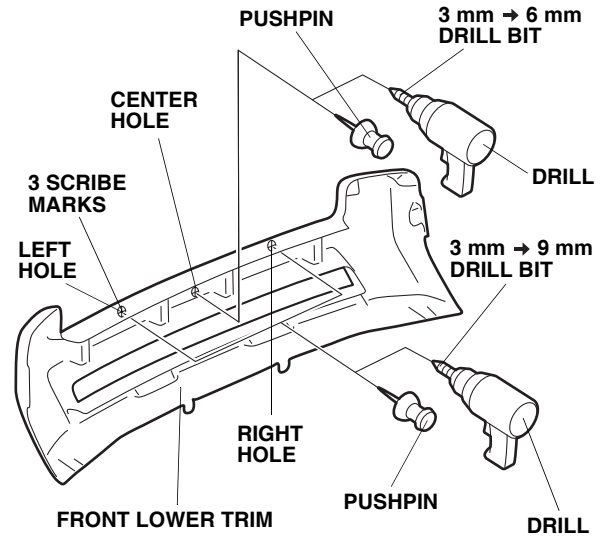

- While wearing eye protection, drill a 3 mm hole at the center hole made in step 6 then widen the hole with a 6 mm drill bit. Remove any burrs.
- Drill a 3 mm hole at the left and right hole made in step 6 then widen the holes with a 9 mm drill bit. Remove any burrs.

9. Using a 14 mm hole saw, widen two elongated holes on the front license frame as shown.

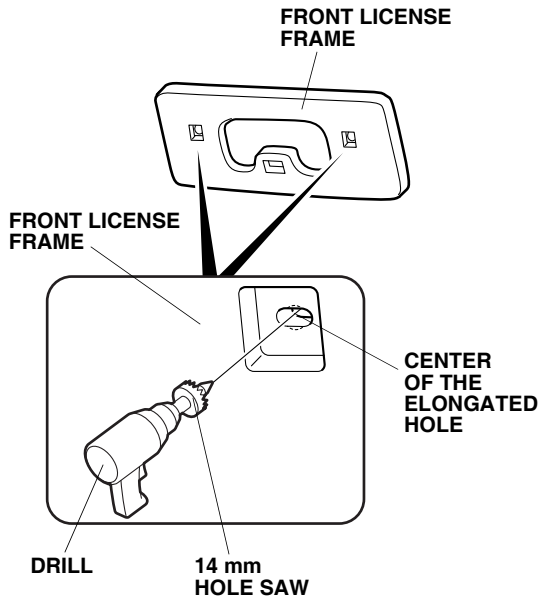

10. Install the front license frame to the front lower trim with one clip, two washer bolts, two collars and two flange nuts.

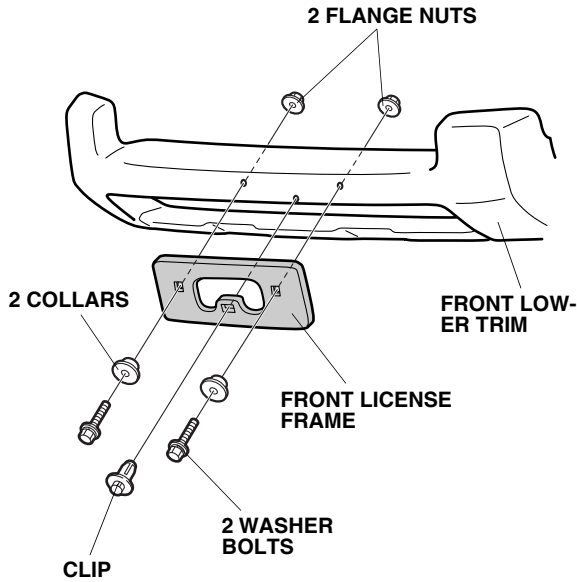

11. Using isopropyl alcohol on a shop towel, clean the area where the front lower trim will attach.

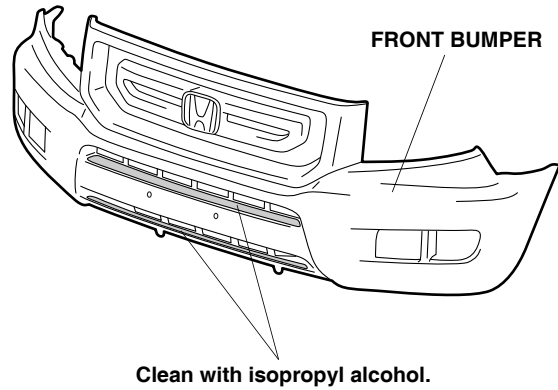

12. Install 10 spring nuts onto the front lower trim.

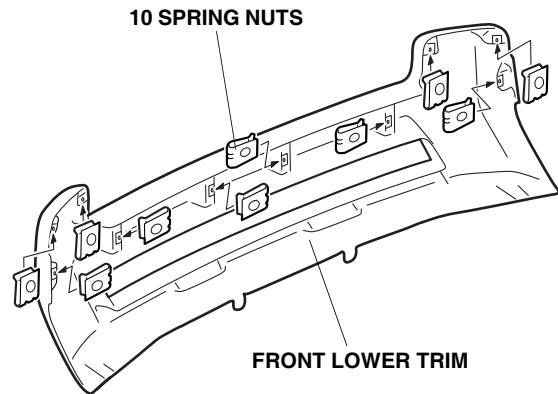

- Cut the center of the adhesive backings as shown. Peel the adhesive backings partway and attach the adhesive backings to the outer surface of the front lower trim.

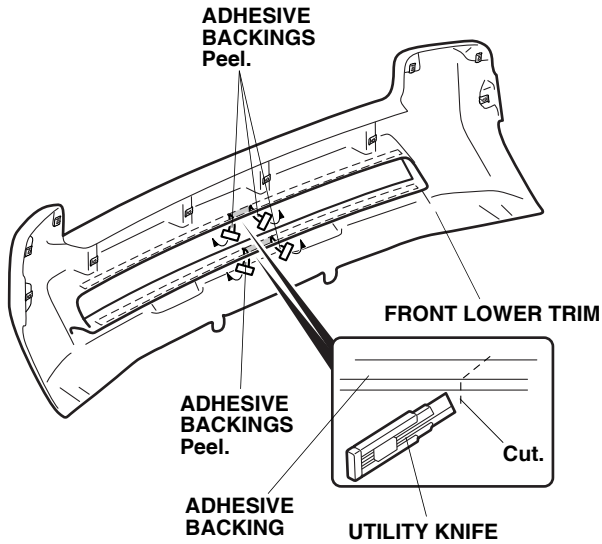

- Loosely secure the front lower trim to the front bumper with ten washer bolts. Make sure the molding on the front lower trim is properly installed on the front bumper. Adjust and unfold the molding if necessary.

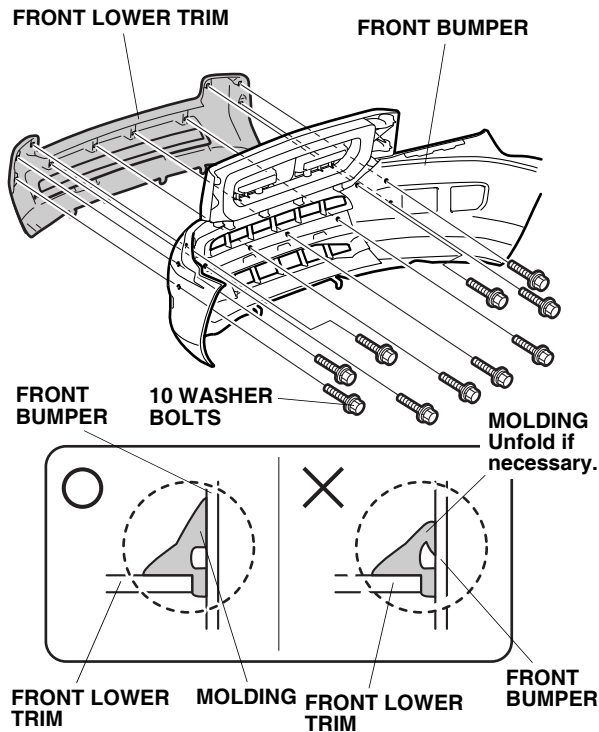

- Loosely secure the front lower trim to the front bumper with six washer bolts and six flange nuts.

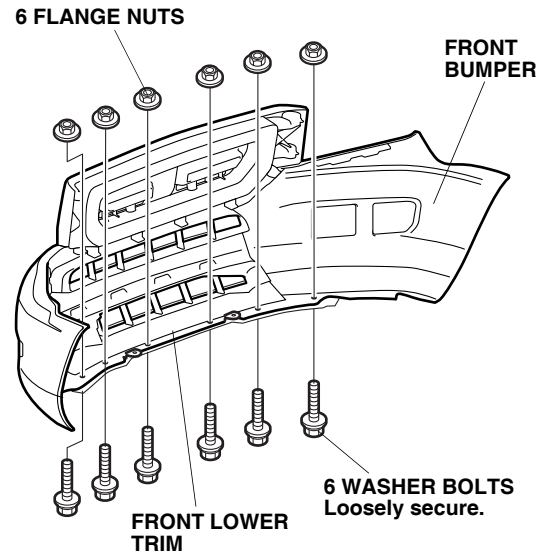

- While applying light pressure against the front lower trim, carefully remove the taped adhesive backings.

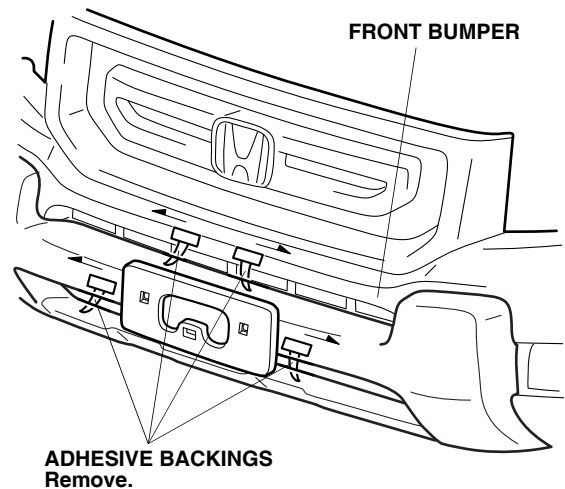

- Using the palm of your hand, firmly press the front lower trim against the front bumper.
- Tighten the washer bolts loosely secured in step 14 and step 15.

19. If the vehicle is equipped with fog lights, plug in the fog light connectors. Reinstall the front bumper to the vehicle with one clip, four bolts, two short step bolts and four self-tapping screws. Have an assistant help you when installing the front bumper.

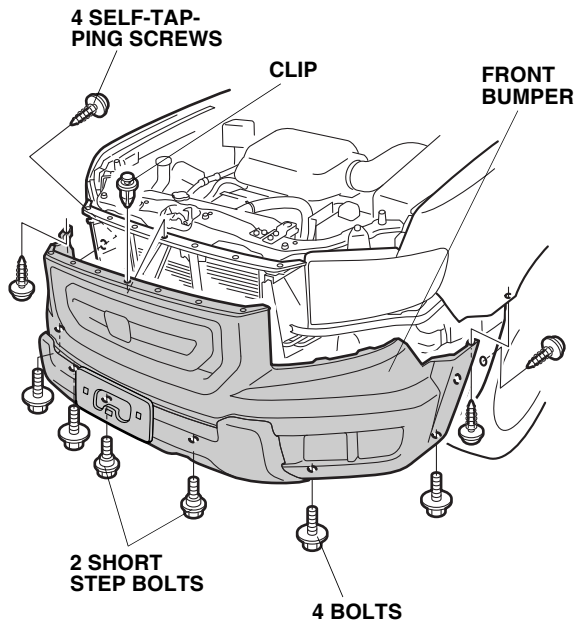

20. Reinstall the air intake duct and the front bulkhead cover.