

<b>INSTALLATION INSTRUCTIONS</b>	Accessory	Application	Publications No.
	<b>BIKE ATTACHMENT P/N 08L07-TA1-102</b>	<b>2011 CR-V</b>	<b>All 44613</b>
			Issue Date <b>AUG 2010</b>
<b>Put this information in the glove box with the vehicle owner's manual.</b>			

**PARTS LIST**

Bike attachments

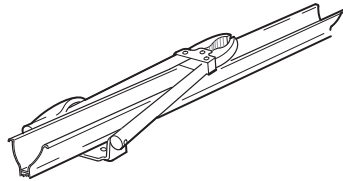

2 Wheel Straps



2 End Caps



2 Keys

**TOOLS REQUIRED**

Flat-tip screwdriver

Shop towel

Utility Knife

**INSTALLATION****NOTE:**

- Be careful not to damage the painted surfaces of the vehicle when installing the bike attachment.
- If you are installing more than one bike attachment, you may need to alternate the mounting positions (front to rear) to allow for handle bar clearance.
- Make sure the security retainer and the locking clamp lever are installed on the outboard side. See the instruction sheet for details

**Preparing the Bike Attachment**

1. Slide the wheel strap onto one end of the bike attachment channel. Repeat on the other end. Make sure both wheel strap buckles are on the same side.

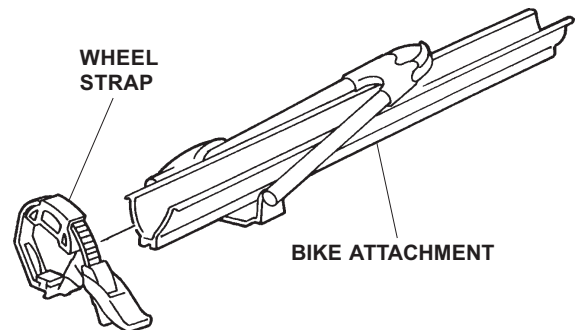

2. Install an end cap on the bike attachment channel by aligning the locktabs on the end cap with the holes in the channel. Push down on the endcap until the lock tabs "click" into place. Repeat on the other end.

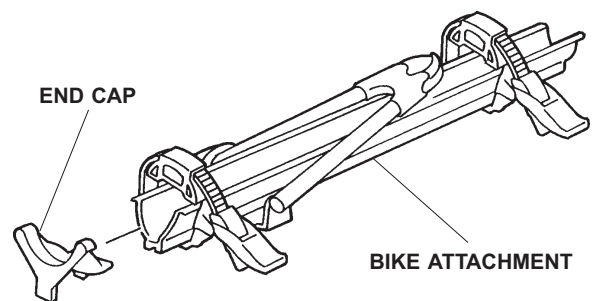

- Turn and loosen the mounting levers on the bike attachment.

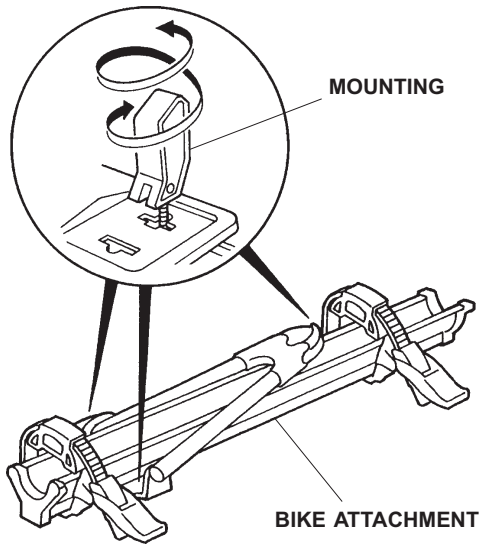

### Installing the Bike Attachment

- Using a flat-tip screwdriver wrapped with a shop towel, push in on the locking tab and remove the roof rack cover. Remove the roof rack cover from the other roof rack the same way.

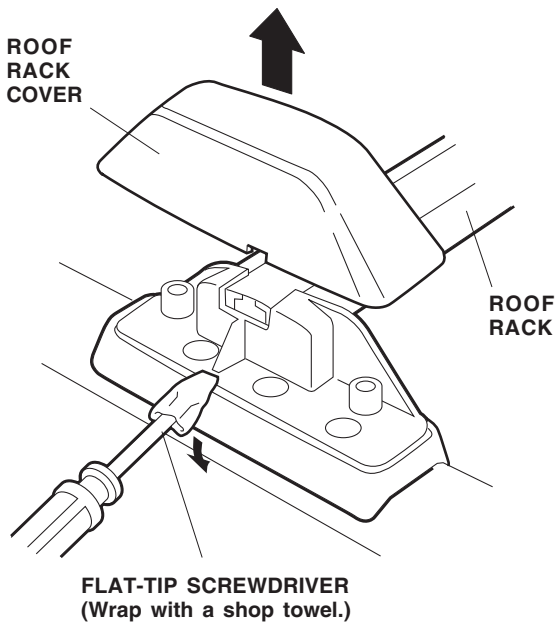

- Remove the rubber moldings from the front and rear roof rack crossbars. Retain the rubber moldings to be reinstalled later.

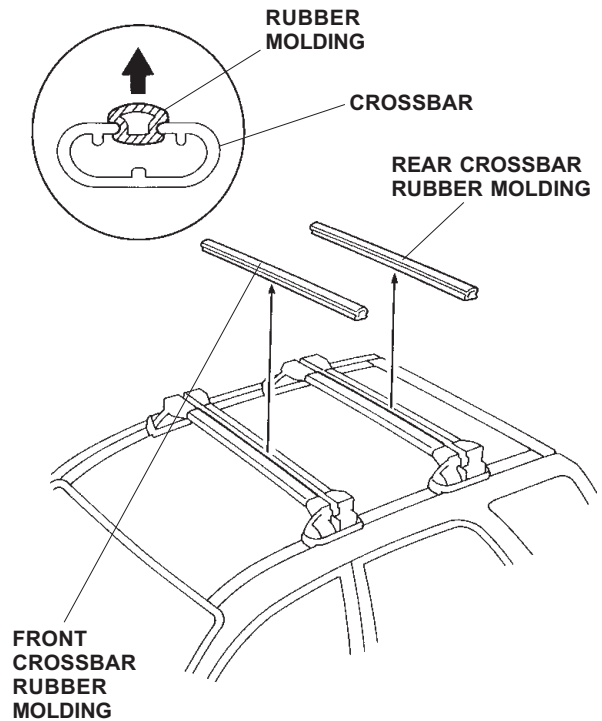

- Insert the T-bolts of the bike attachment through the oval cutout in each crossbar (two T-bolts for the front of the bike attachment, and one T-bolt for the rear), and position the bike attachment on the front and rear crossbars.

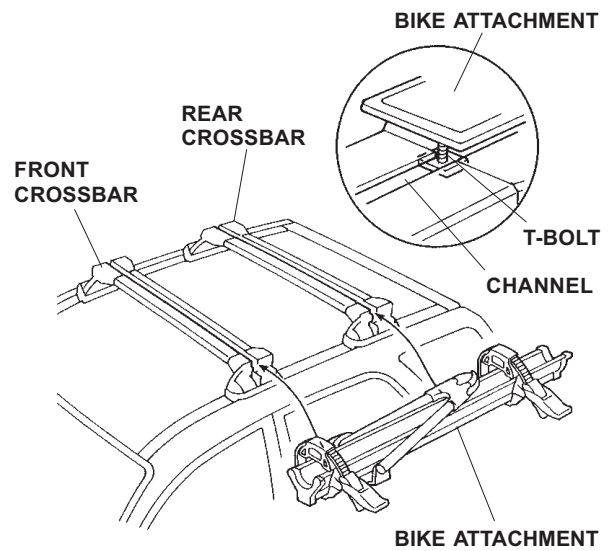

- Turn and adjust the mounting lever to lock the bike attachment to the roof rack. Check for firm pressure when you push down on the mounting lever to lock it into place.

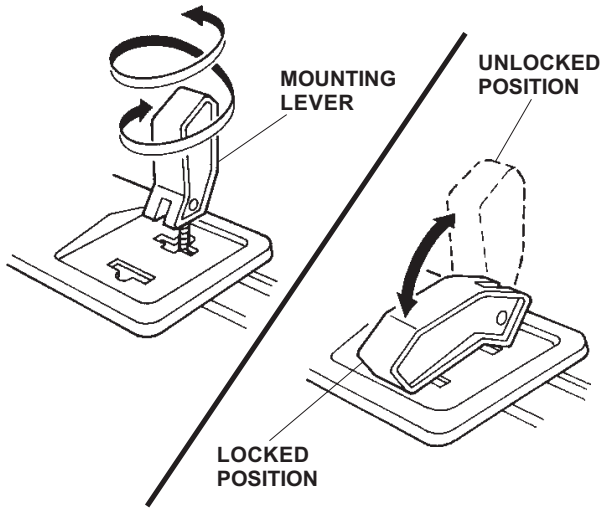

- If the mounting lever pressure is too tight (the lever will not lock into place), lift up on the lever and turn it counterclockwise.
- If the mounting lever pressure is too loose (the lever locks into place, but the bike attachment is loose on the crossbars), lift up on the lever and turn it clockwise.

- Slide the security retainer in place; then close the locking clamp lever. To deter theft of the bike attachment, lock the locking clamp lever with the key.

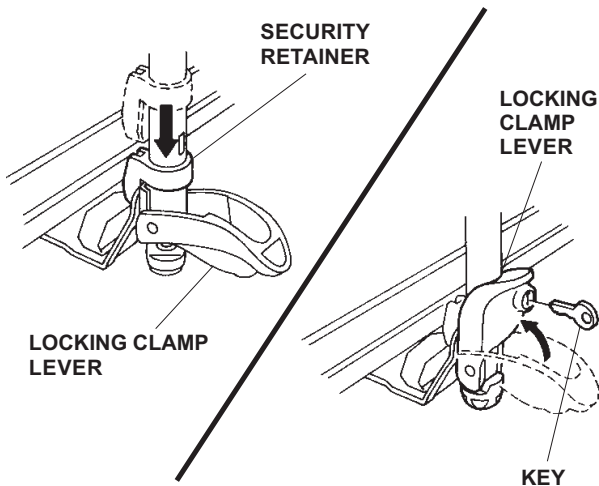

- Reinstall the roof rack covers on the roof rack.

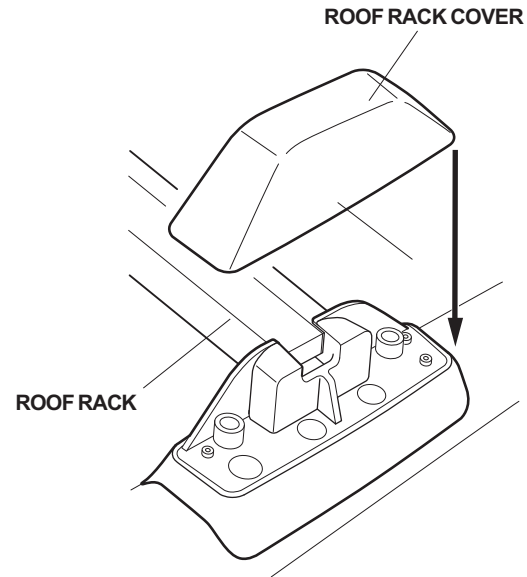

- To prevent excess wind noise, cut each rubber molding and install the cut pieces into the grooves in the crossbars.

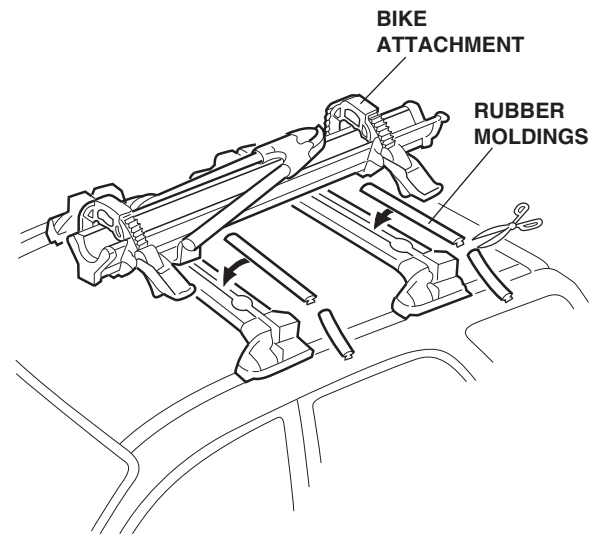

- Put these instructions and the Bicycle Installation Instruction sheet in the glove box.
- Tell the customer to write down the key number and put the number in a safe place in case the key is lost or stolen.