

**PARTS LIST****Tonneau Cover Kit**

Tonneau Cover

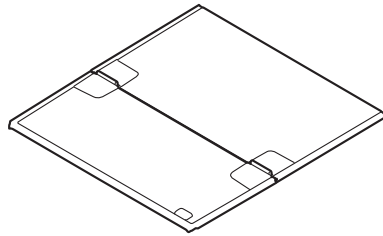

4 Brackets

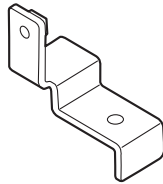

6 Screw clips

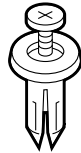

Washer



4 Plate nuts



4 Washer-bolts, 6 x 14 mm



4 Washer-bolts, 6 x 20 mm

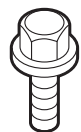

6 Water stops



Left seal



Right seal



4 Rubber grommets

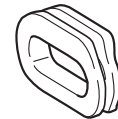

Left rail cap

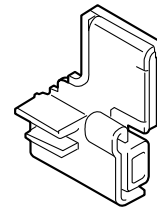

Right rail cap

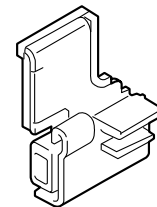

Left rail (four holes)

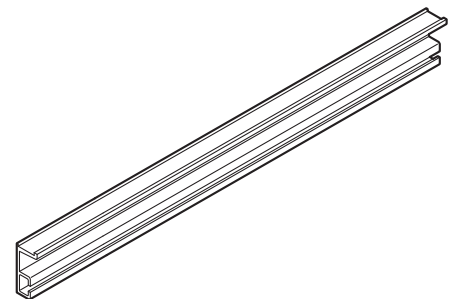

Right rail (five holes)

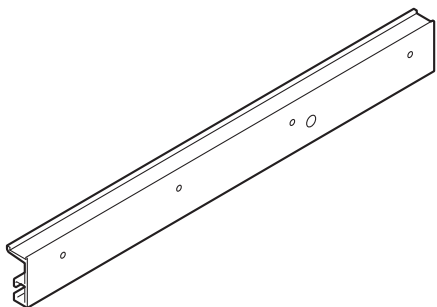

Bed front panel rail

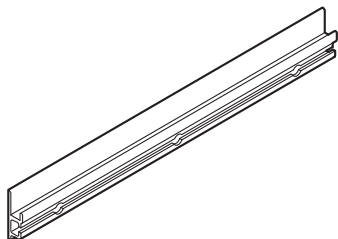

2 Brackets A

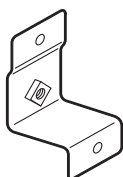

Bracket B



2 Brackets C

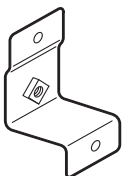

2 Brackets D



3 Collars

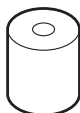

3 Long flange bolts

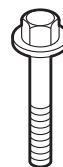

14 Short flange bolts



8 Bumper bolts



7 Clips



Circle grommet



6 Ellipse grommets



Lock bracket

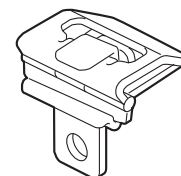

2 Keys



2 Cushion tapes

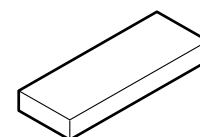

Accessory User's Information Manual

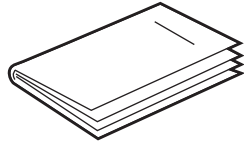

**Shim Kit**  
2 Shims



Primer

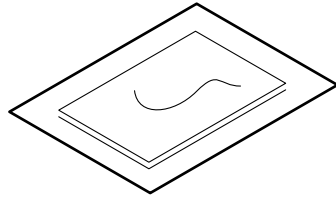

Alcohol pad

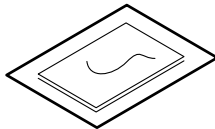

Guide for installing the shims

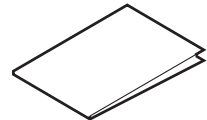

**Wedge Kit**  
6 Wedges

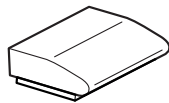

Alcohol pad

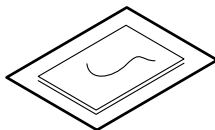

Guide for installing the wedges

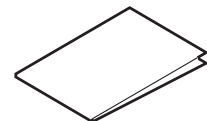

## TOOLS AND SUPPLIES REQUIRED

Phillips screwdriver  
Flat-tip screwdriver  
Torque wrench  
10 mm Socket  
Ratchet  
Drill  
T-40 and T-50 Torx wrenches  
3 mm, 6 mm and 10 mm Drill bits  
Step drill bit  
15 mm and 25 mm Hole saws  
Eye protection (face shield, safety goggles, etc.)  
File  
Tape measure  
Scale  
Gloves  
Isopropyl alcohol  
Shop towel  
Utility knife  
Hacksaw  
Rubber mallet  
Hard plastic plate (approx. 50 mm x 80 mm x 1 mm)  
Felt-tip pen  
Dryer  
Trim Tool Set (T/N SOJATP2014)  
10 mm Wrench  
Electrical tape  
Hex wrench

***Illustration of the Tonneau Cover installed on the vehicle***

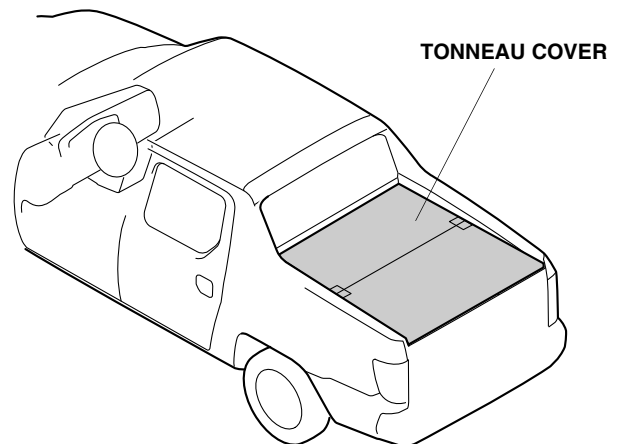

## INSTALLATION

**Customer Information:** The information in this installation instruction is intended for use only by skilled technicians who have the proper tools, equipment, and training to correctly and safely add equipment to your vehicle. These procedures should not be attempted by “do-it-yourselfers.”

### NOTE:

- Do not damage the paint finish.
- This kit should be installed only if the ambient air temperature is 15°C (60°F) or above. Heat the tonneau cover and bonding surface with a hair dryer set on LOW if the ambient air temperature is below 15°C (60°F).
- To allow the adhesive to cure, do not wash the vehicle for 24 hours. Please advise the customer.

1. Make sure you have the anti-theft code for the radio, then write down the radio station presets.
2. Disconnect the negative cable from the battery.

### Installing the Tonneau Cover

3. Remove the right front upper tie-down hook (two T-50 torx bolts).

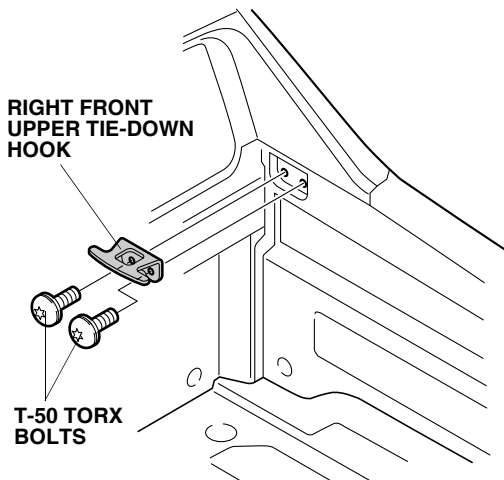

4. Remove the left front upper tie-down hook (two T-50 torx bolts).

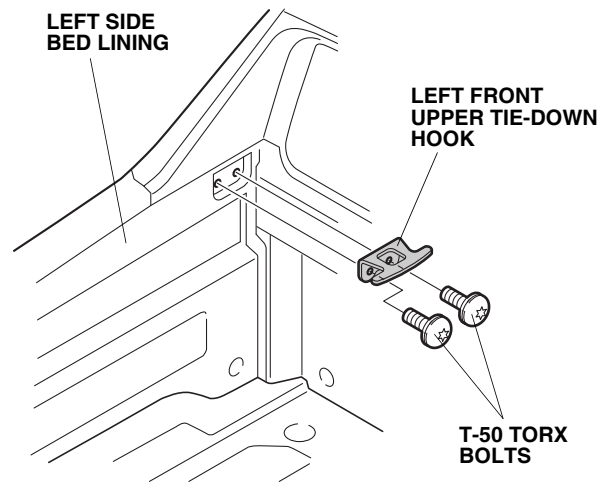

5. Remove the bed front panel (six T-40 torx bolts).

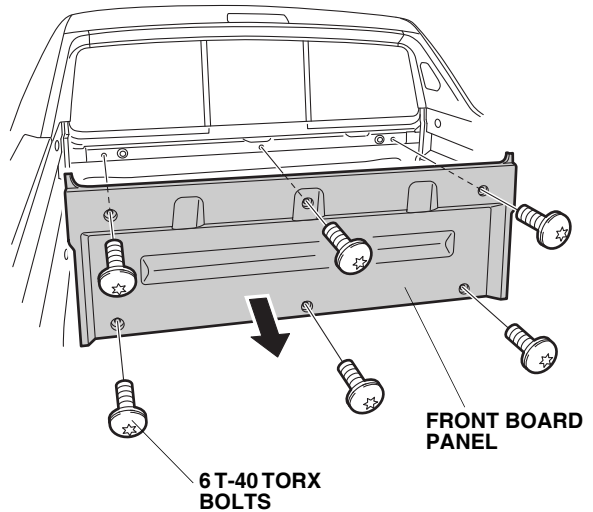

- While wearing eye protection, enlarge the three upper holes in the bed front panel with a 25 mm hole saw. Remove all burrs.

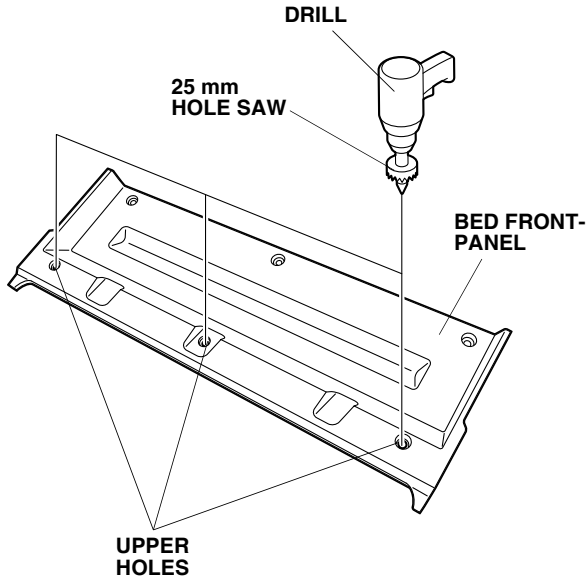

- While wearing eye protection, drill eight marks on the inside of the bed front panel with a 3 mm drill bit.

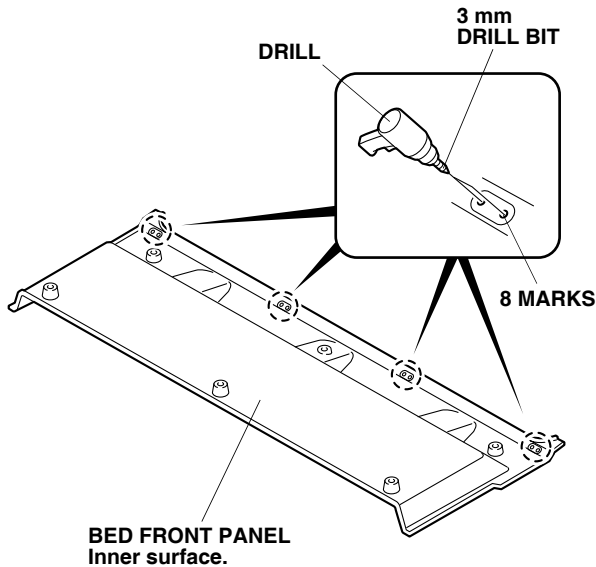

- While wearing eye protection, drill the eight holes made in step 7 with a 15 mm hole saw. Drill the outer surface of the bed front panel. Remove all burrs.

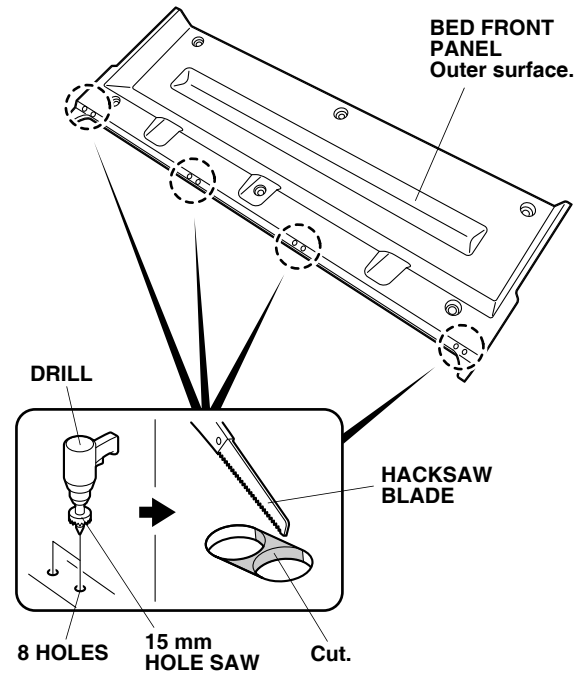

- Using a hacksaw blade, cut between the holes in four places as shown.
- Install four rubber grommets into the four holes made in step 9.

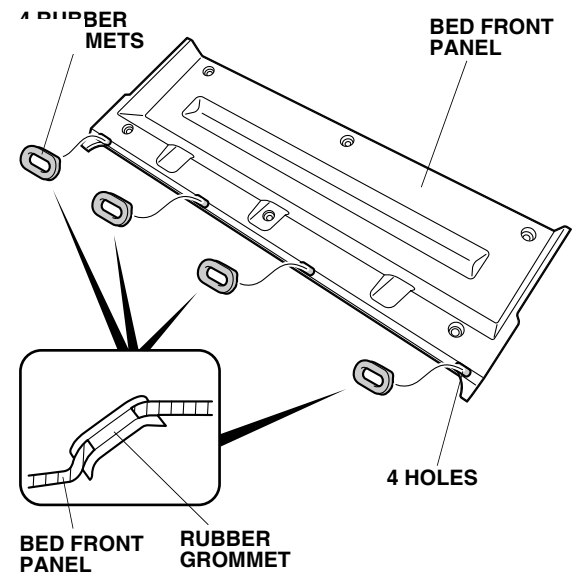

11. Remove the screw cover (four retaining tabs).

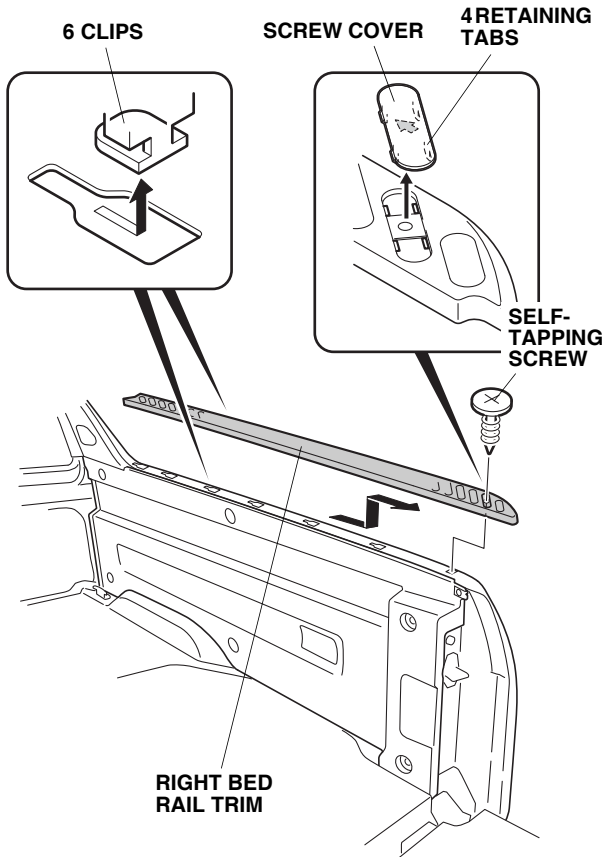

12. Remove one self-tapping screw from the rear of the right bed rail trim.
13. Slide the right bed rail trim toward the back to release the six clips, then remove the right bed rail trim.
14. Repeat steps 11 through 13 to remove the left bed rail trim.

15. Remove two roof rear trim bolt covers (three retaining tabs on each cover). Remove two roof trim nuts.

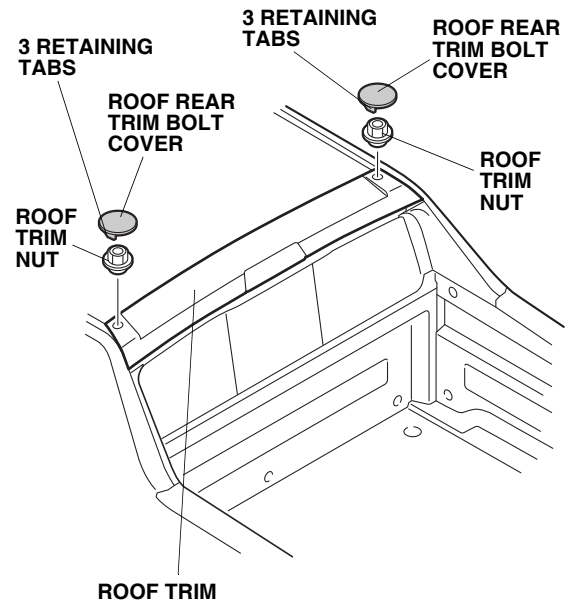

16. Using a plastic trim tool, carefully pry up the front of the roof trim to release three front clips. Start with the left clip, and work your way to the right clip.

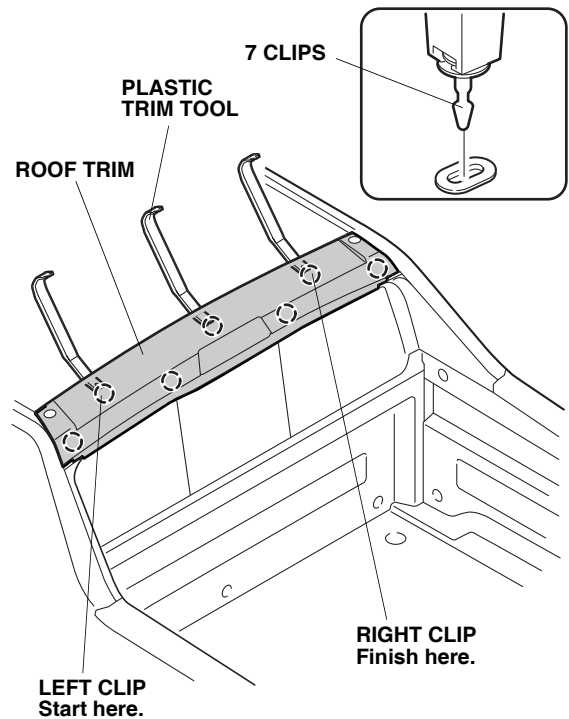

17. Gently lift the front of the roof trim to release four remaining clips.

18. Gently pull up the roof trim to release two hooks.

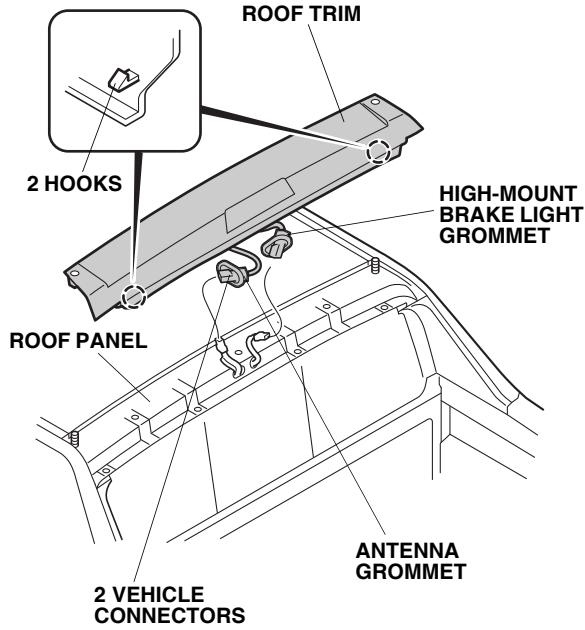

19. Remove the antenna grommet and high-mount brake light grommet from the roof panel, unplug the vehicle connectors, and remove the roof trim.
20. Remove the left C-pillar outer trim (three clips and unplug the vehicle connector).

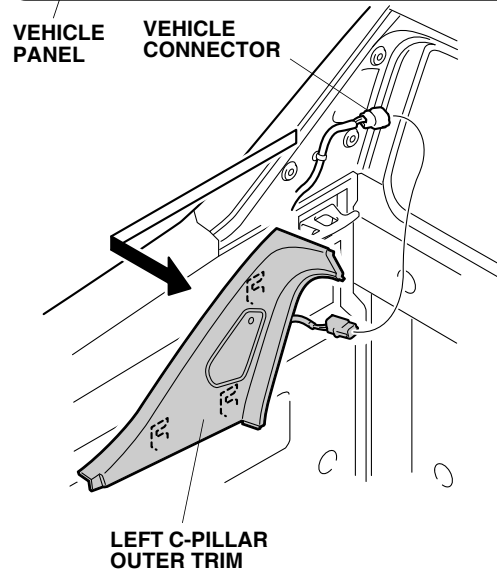
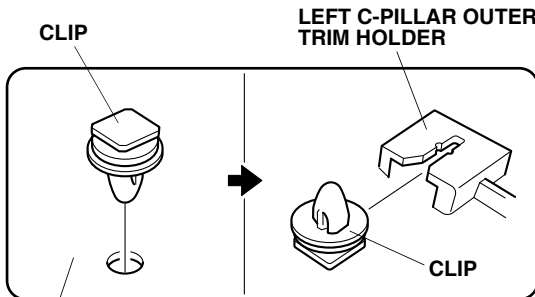

21. Remove the three vehicle clips from the vehicle panel, and install them to the left C-pillar outer trim holders.
22. Remove the two left rear tie-down hooks (four T-50 torx bolts).

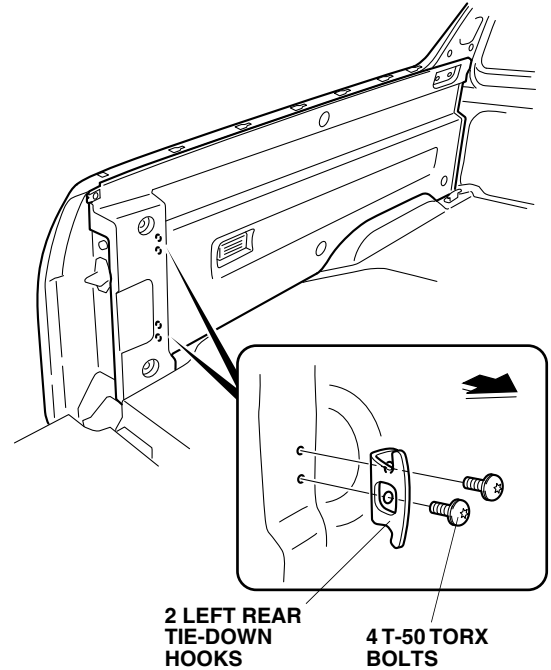

*If the vehicle is equipped with a bed extender, continue with step 23. If not, go to step 24.*

23. Remove the left latch (three hex bolts).

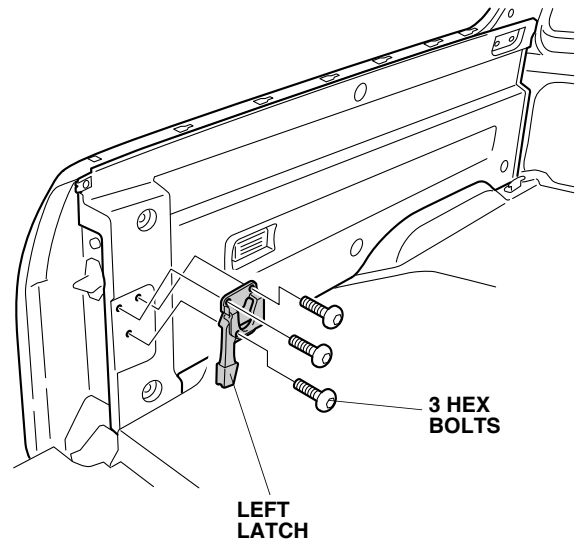

24. Remove the left lower light (one self-tapping screw and unplug the vehicle connector).

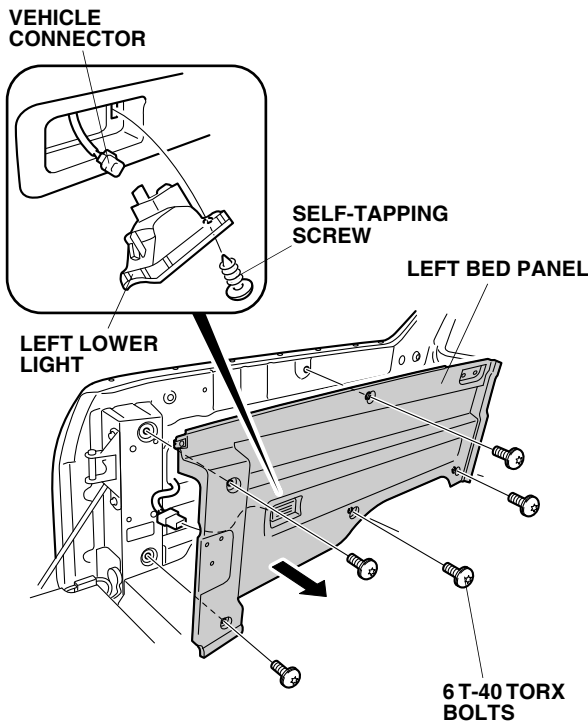

25. Remove the left side bed lining (five T-40 torx bolts, one clip, and unplug the vehicle connector).
26. Repeat steps 20 through 25 to remove the right side bed lining. The right side bed lining has an additional clip for the spare tire tie down hook. Remove it before removing the right side bed lining.
27. While wearing eye protection, drill the eight marked locations on the left side bed liner with a 3 mm drill bit.

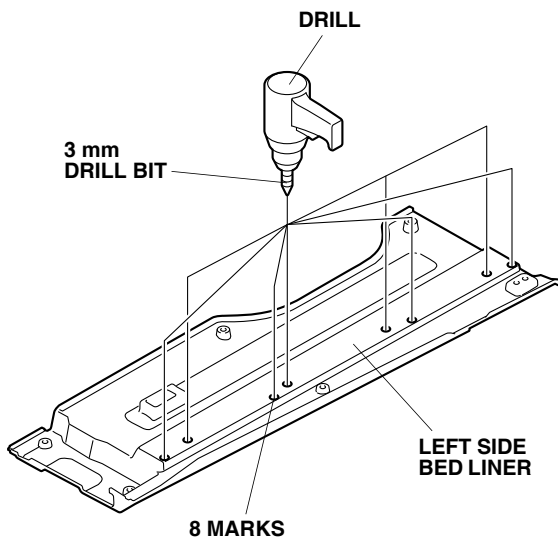

28. Turn over the left side bed liner. While wearing eye protection, enlarge the eight holes with a 15 mm hole saw.

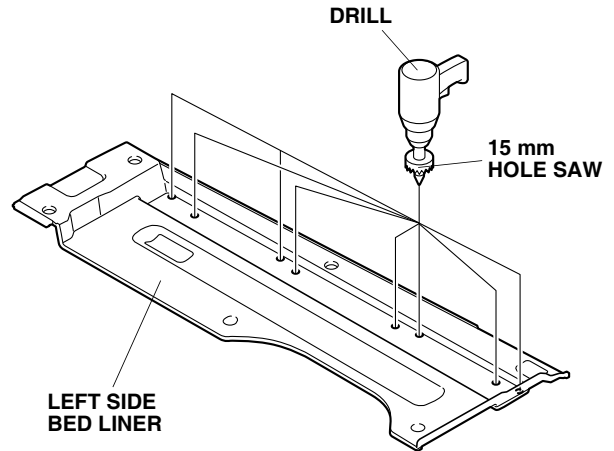

29. Repeat steps 27 and 28 on the right side bed liner.
30. Drill three locations on the bed floor panel with a 10 mm drill bit. These holes are for water drainage. To prevent damage, wrap tape around the drill bit 30 mm away from the tip as shown.

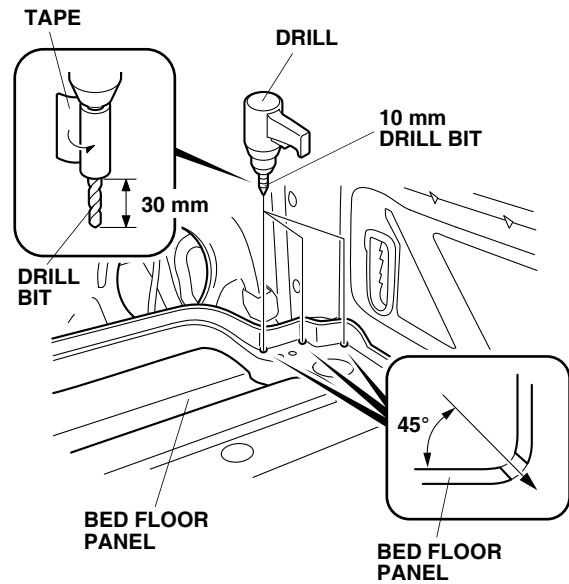

31. Drill three water drainage holes in the same location on the other side of the bed.

32. Using isopropyl alcohol on a shop towel, thoroughly clean the area on the left side bed liner where the seal will attach.

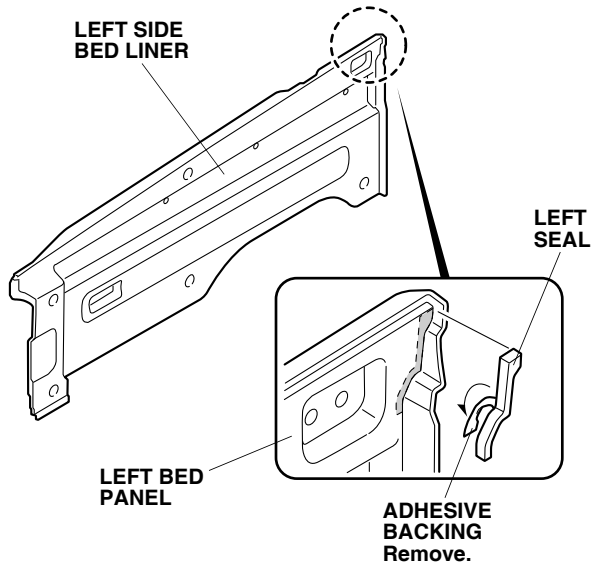

33. Align and attach the left seal to the left side bed liner.  
 34. Repeat these steps to install the right seal on the right side bed liner.  
 35. Install brackets A, B, C and D to the left side of the bed with eight short flange bolts. Torque the bolts to 10 N·m (1.0 kgf·m, 7.4 lbf·ft).

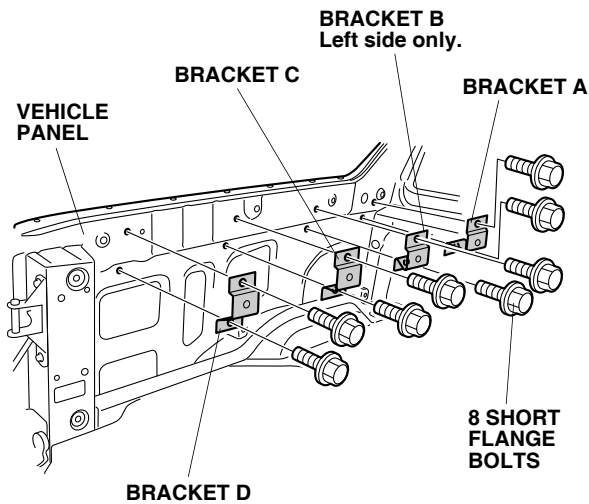

36. Install brackets A, C and D to the right side of the bed with six short flange bolts. Torque the bolts to 10 N·m (1.0 kgf·m, 7.4 lbf·ft).

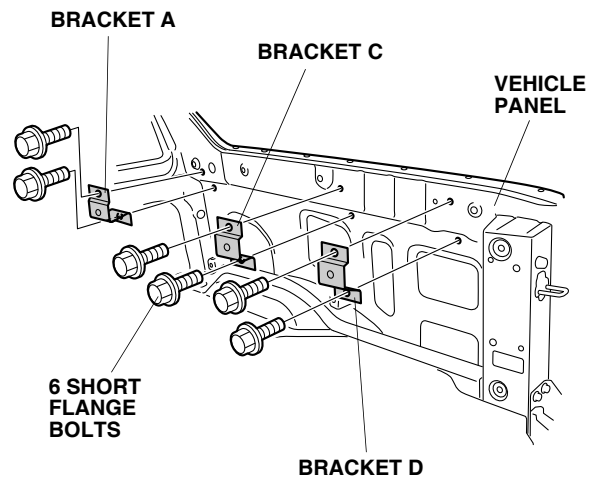

37. Mark the left side of the bed at the measurements shown.

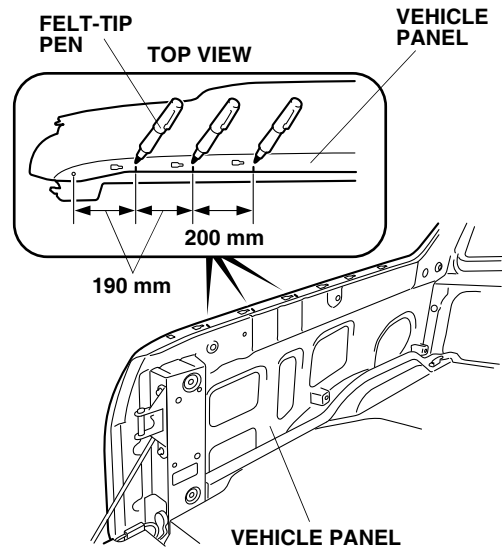

38. Using isopropyl alcohol on a shop towel, thoroughly clean the areas where the wedges will attach.

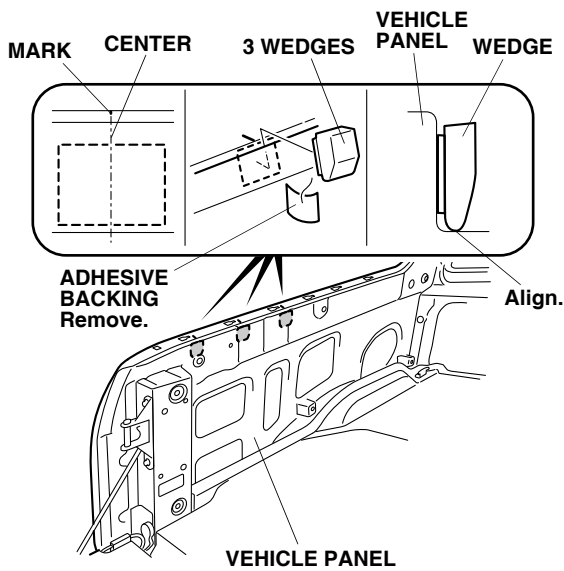

39. Remove the adhesive backings from three wedges, and attach them to the vehicle panel as shown.  
 40. Repeat steps 37 thru 39 to install wedges on the right side of the bed.  
 41. Reinstall the left and right side bed liners.  
 42. Reinstall the left and right C-pillar outer trim panels.  
 43. Remove seven grommets from the roof panel. Install six new ellipse grommets and one new circle grommet into the roof panel as shown.

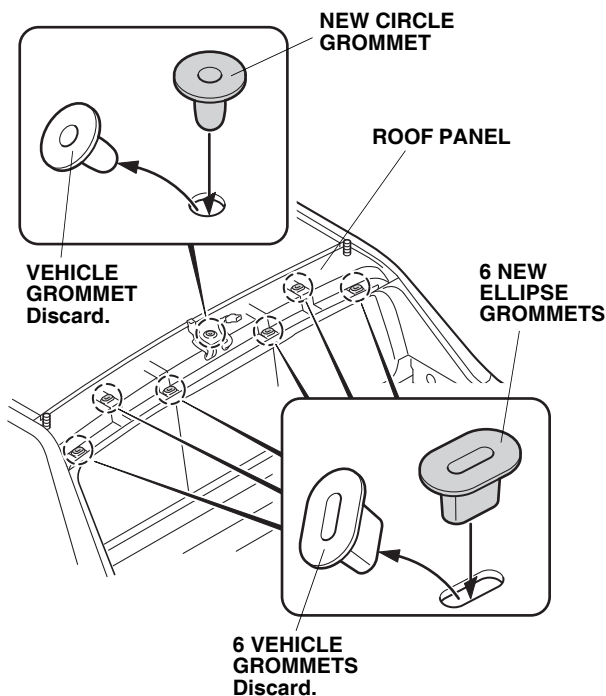

44. Remove seven clips from the roof trim, and install seven new clips.

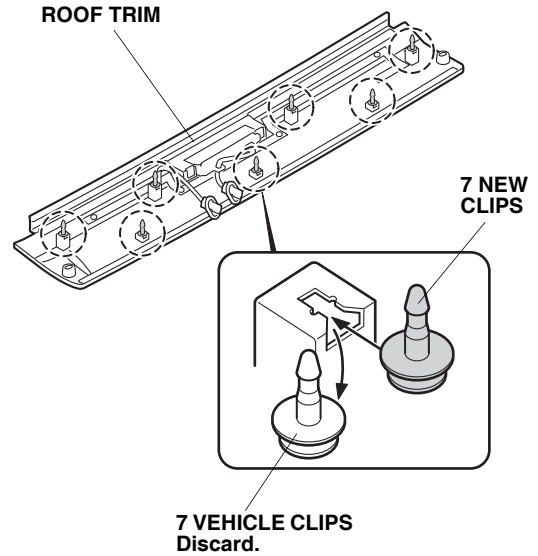

45. Reinstall the roof trim.  
 46. Fit the left rail cap onto the bed front panel rail at an angle so that you do not damage the seal.

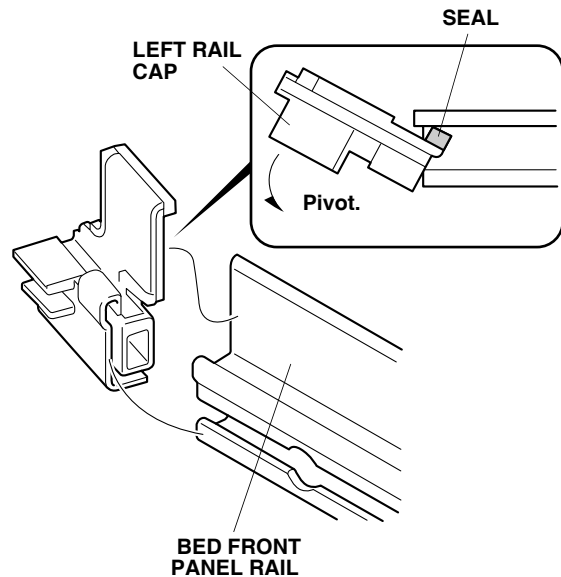

47. Slide the left rail cap onto the bed front panel rail while raising the upper rear towards the front.

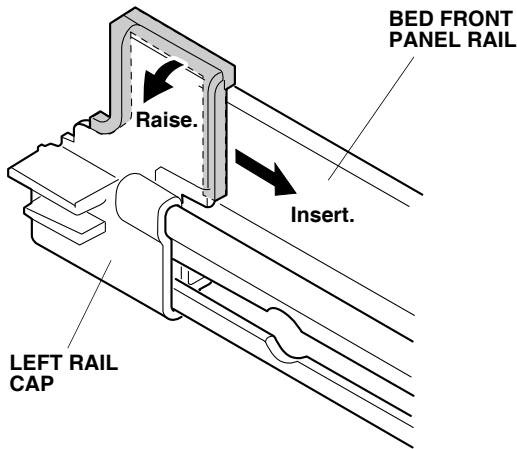

48. Repeat steps 46 and 47 to install the right rail cap.  
 49. Using isopropyl alcohol on a shop towel, thoroughly clean the areas where the water stops will attach.

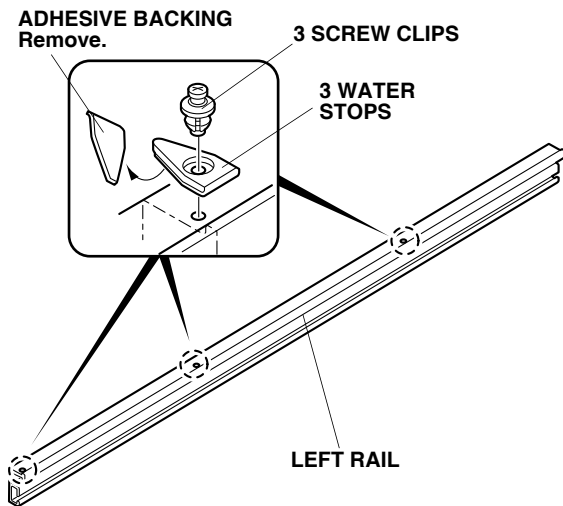

50. Remove three adhesive backings from three water stops and attach them to the left rail.  
 51. Secure three water stops to the left rail with three screw clips.  
 52. Repeat steps 49 thru 51 to install water stops on the right rail.

53. Loosely secure the front bed panel to the vehicle with three T-40 torx bolts removed in step 5.

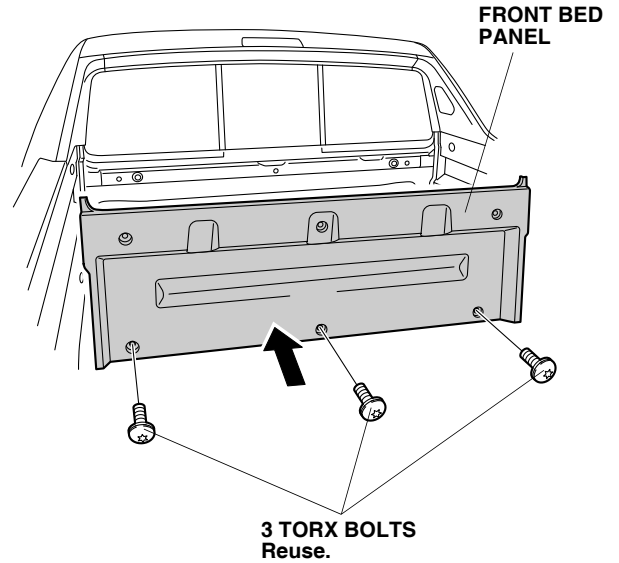

54. Make sure that the seals attached in steps 32 and 34 are not twisted or collapsed. If they are, straighten them by inserting a ruler or flat-tip screwdriver.

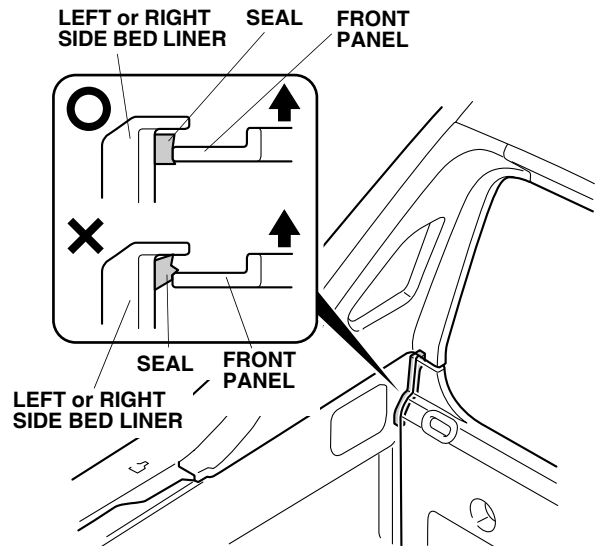

55. Loosely secure the bed front panel rail to the vehicle with three collars, one washer and three long flange bolts.

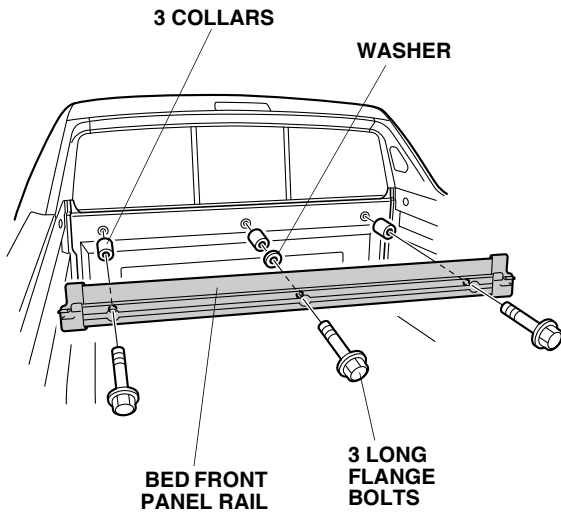

56. Use a rubber mallet to tap on the left side bed liner and work the gutter on the left rail cap into the drain hole. Repeat on the right side. Take care to not damage the gutter on the rail cap.

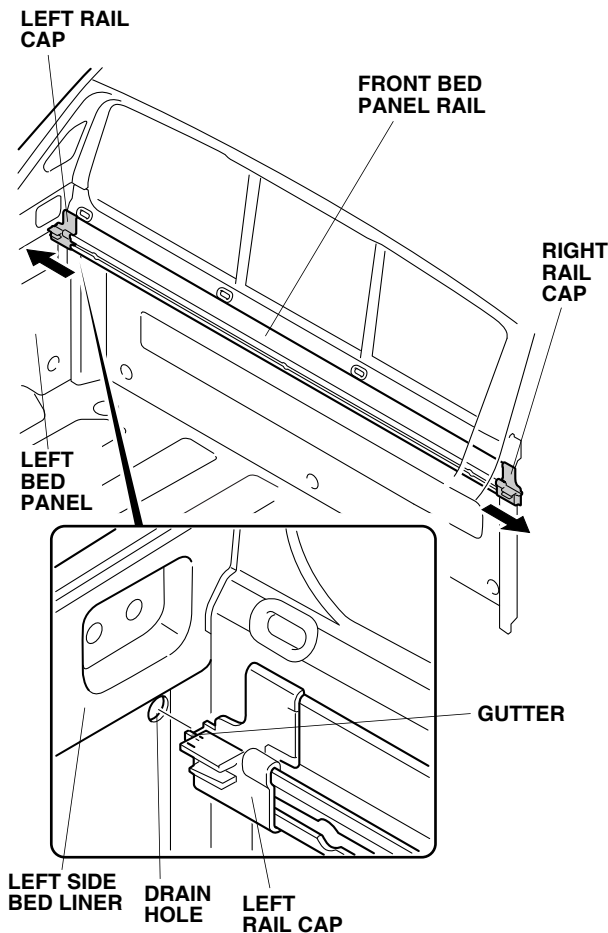

57. Tighten the three T-40 torx bolts loosely installed in step 53.
58. Tighten the three long flange bolts loosely installed in step 55. Torque the bolts to 10 N·m (1.0 kgf·m, 7.4 lbf·ft).
59. Install the left rail to the left side of the bed with four bumper bolts. Torque the bolts to 10 N·m (1.0 kgf·m, 7.4 lbf·ft). Make sure the rail fits into the rail cap on the bed front panel rail.

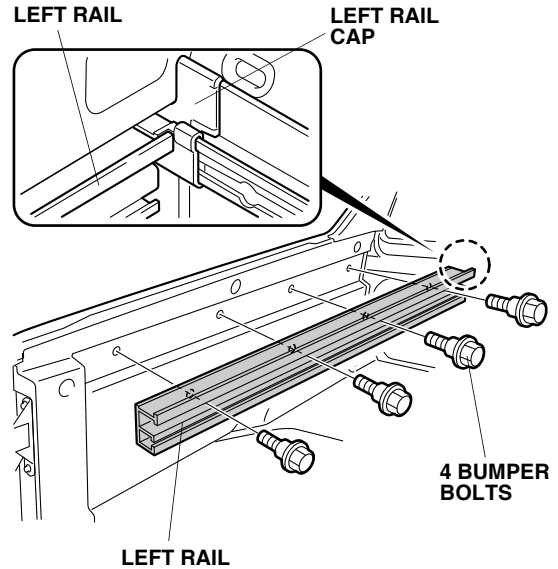

60. Insert two plate nuts into the channel on the left rail.

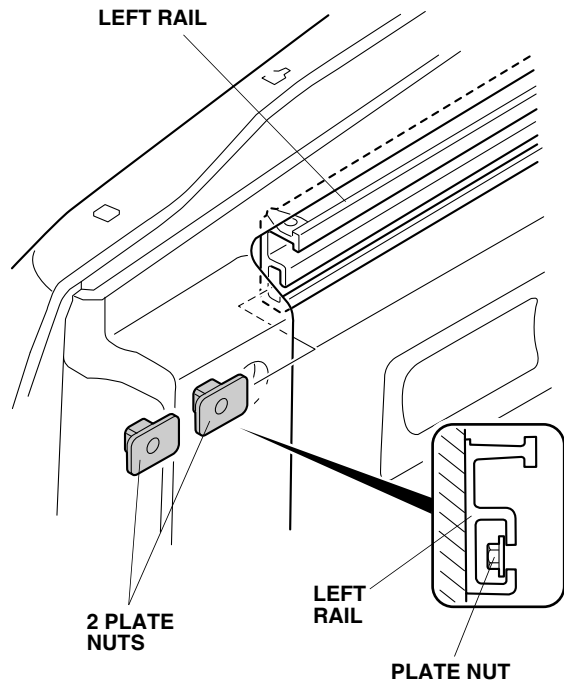

- 61. Repeat steps 59 and 60 to install the right rail.
- 62. Remove four screws and release two end clips.

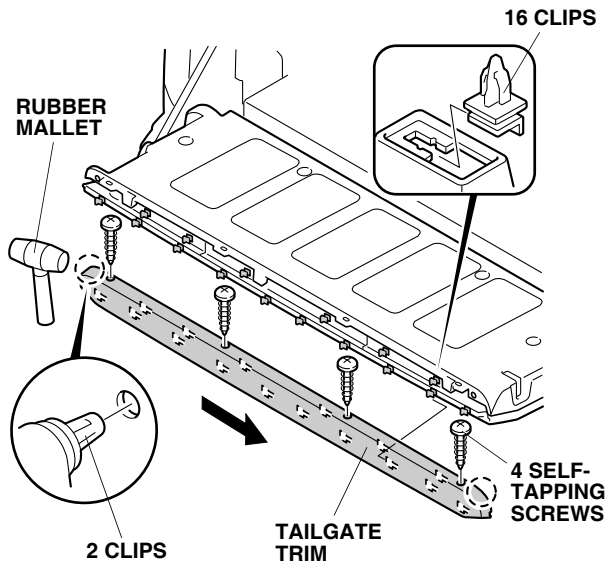

- 63. Use a rubber mallet to tap the tailgate to the right and release the sixteen clips.
- 64. Remove the sixteen clips from the tailgate and install them onto the tailgate trim as shown.
- 65. Using a felt-tip pen, mark the tailgate panel at the center of the torx bolt as shown.

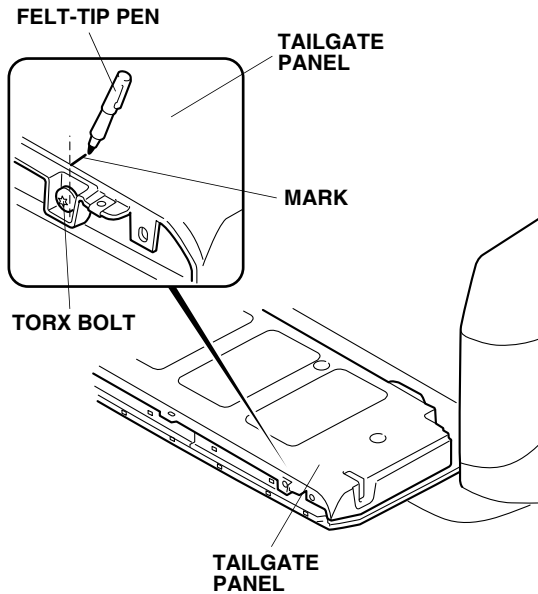

- 66. Reinstall the tailgate trim.

- 67. Using a felt-tip pen, mark the tailgate trim in line with the mark on the tailgate panel made in step 65.

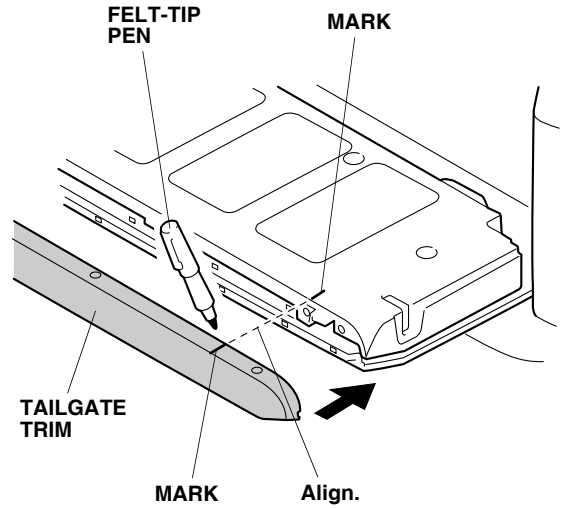

- 68. Remove the tailgate trim. Measure and cut the tailgate trim as shown.

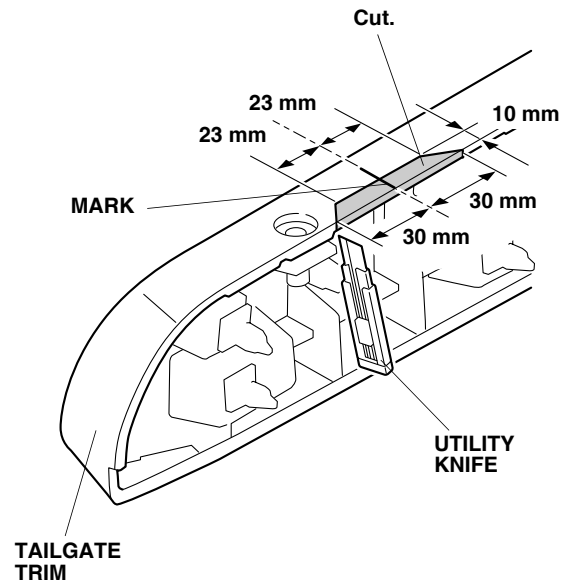

69. Remove the torx bolt from the tailgate. Install the lock bracket to the tailgate with the torx bolt just removed.

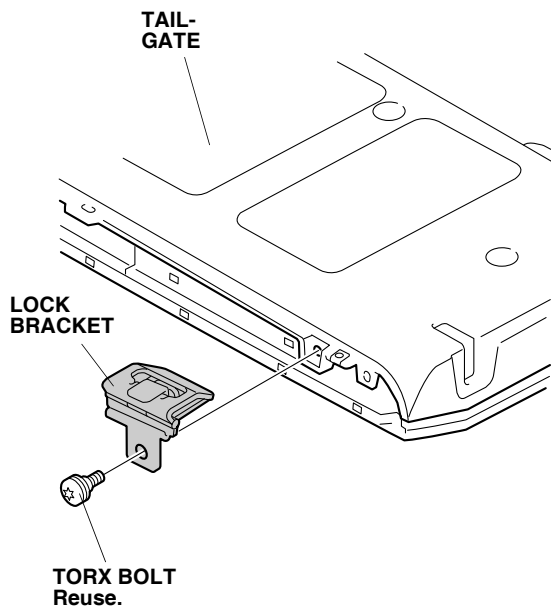

70. Reinstall the tailgate trim.  
71. Reinstall the tie down hooks.  
72. Fold the tonneau cover. Position it on the bed. Align the groove in the tonneau cover with the ridge on the bed front panel rail. Have an assistant help you when installing the tonneau cover.

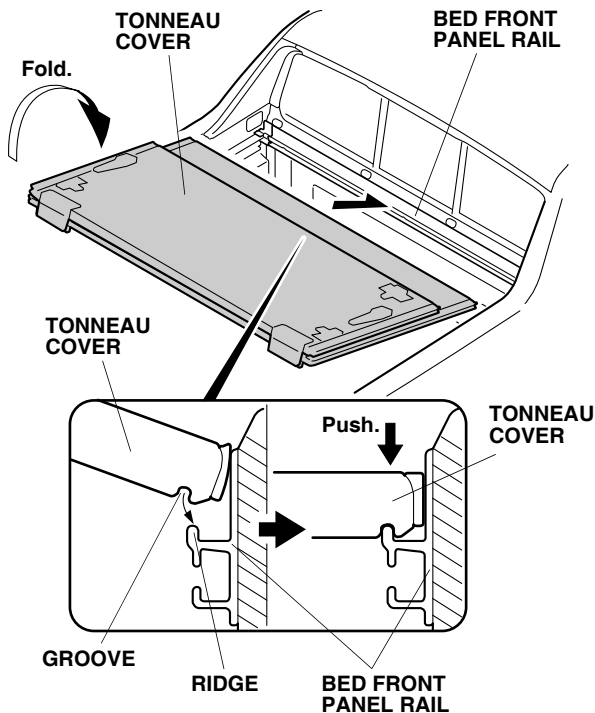

73. Loosely install four brackets to the plate nuts with four 6 x 20 mm washer-bolts. Do not tighten the washer-bolts yet. Position the brackets on the left side in front of the tonneau cover brackets. Position the brackets on the right side behind the tonneau cover brackets.

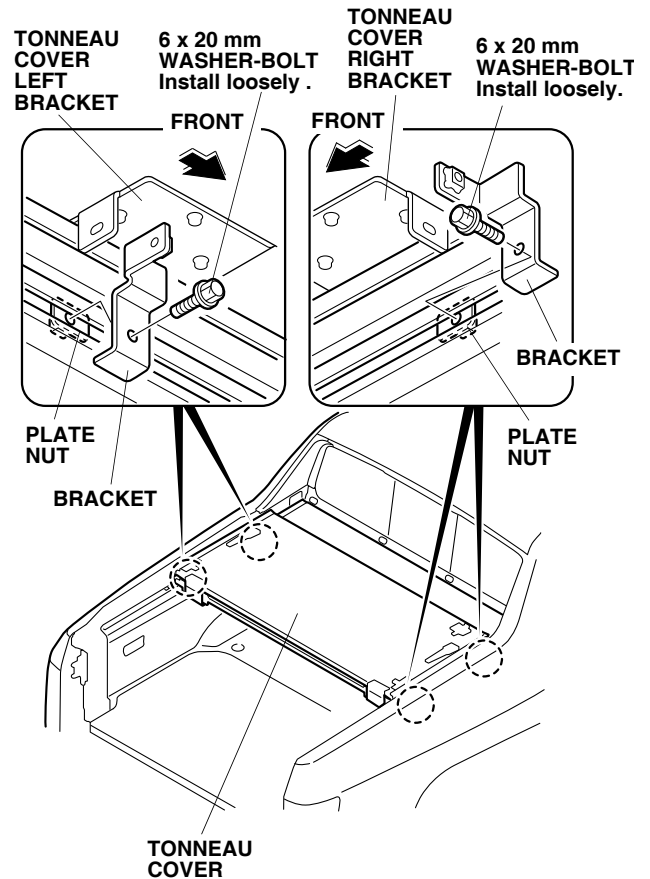

74. Secure the four brackets to the four tonneau cover brackets with 6 x 14 mm washer-bolts. Torque the washer-bolts to 10 N·m (1.0 kgf·m, 7.4 lbf·ft).

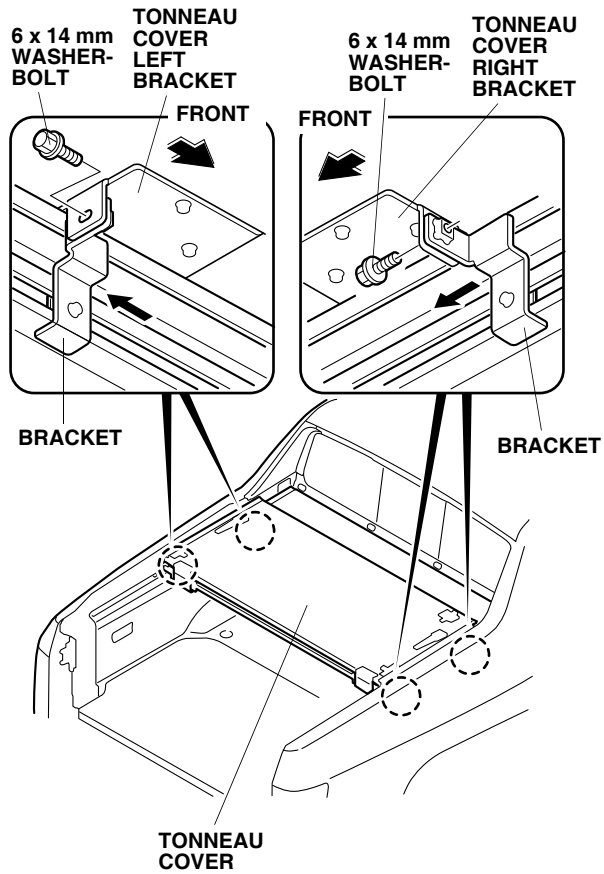

75. Open the tonneau cover. Using a hard plastic plate (approx. 50 mm x 80 mm x 1 mm) or equivalent material, seat the right and left side seals as shown. Do not use a flat-tip screwdriver.

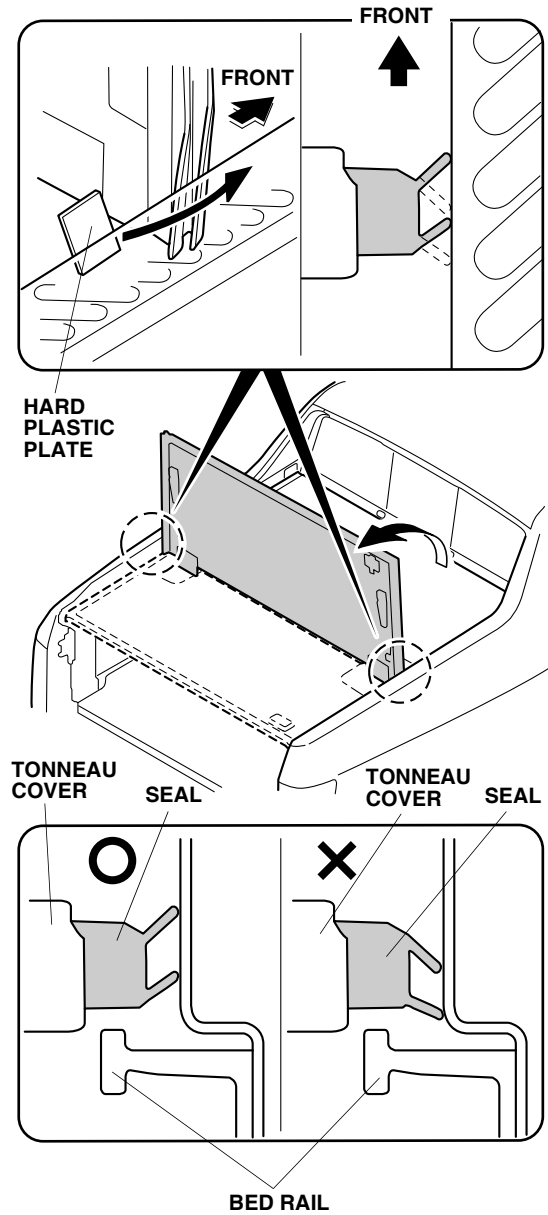

76. Open and close the tailgate several times to position the tonneau cover correctly. Then tighten the four washer-bolts loosely secured in step 73. Torque the washer-bolts to 10 N·m (1.0 kgf·m, 7.4 lbf·ft).

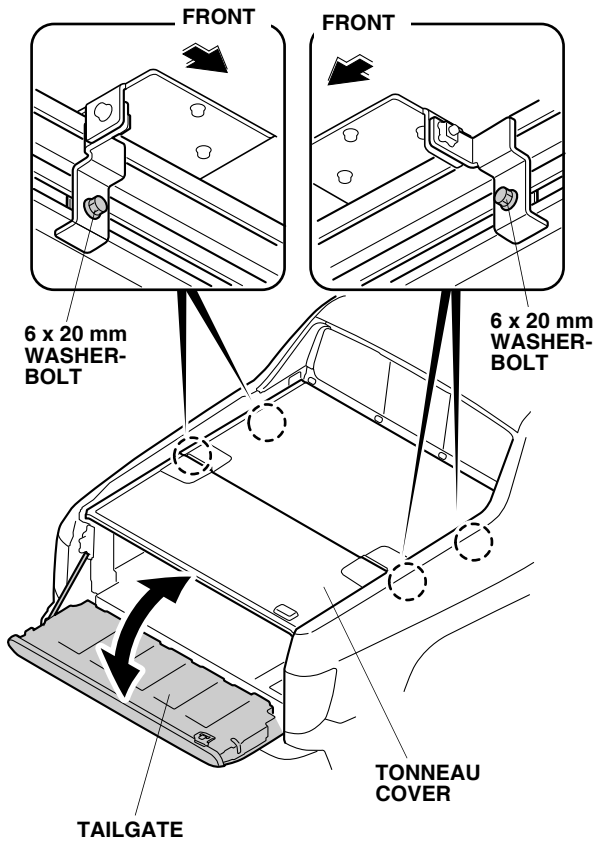

77. Have an assistant hold up the back of the tonneau cover. Using isopropyl alcohol on a shop towel, thoroughly clean the areas where the cushion tapes will attach.

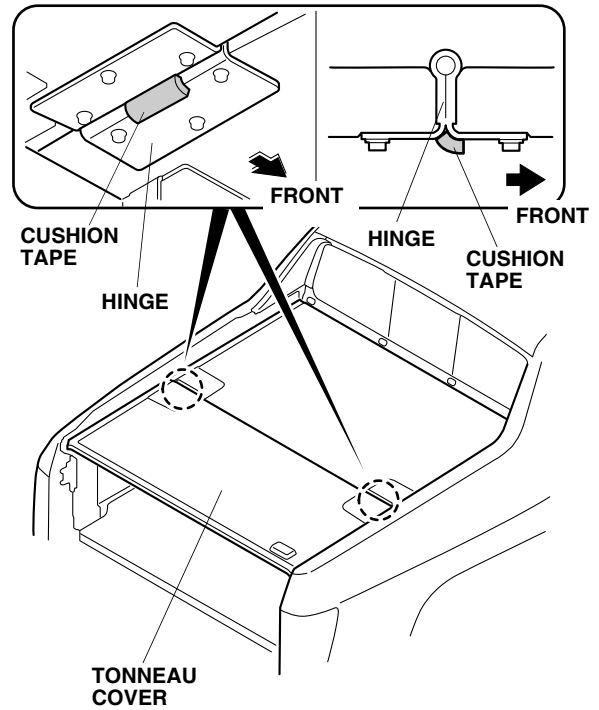

78. Attach two cushion tapes to the hinges on the tonneau cover as shown.  
79. Turn two knobs to lock the rear of the tonneau cover.

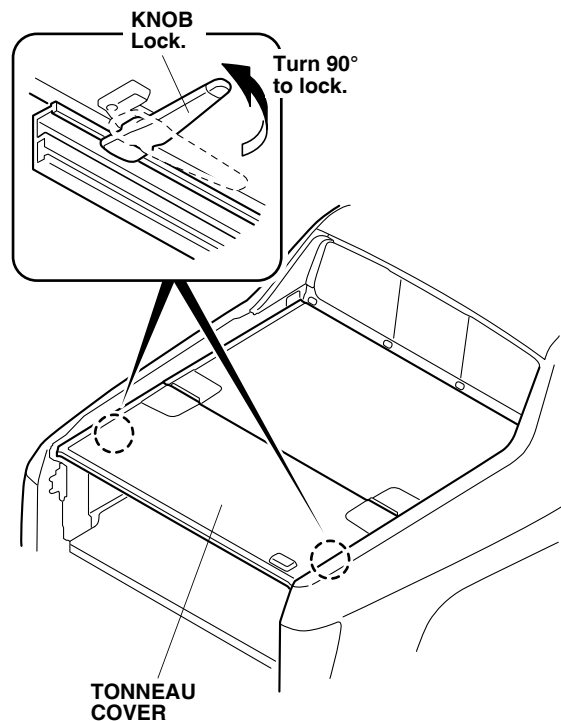

80. Push down on the tonneau cover key cylinder to engage the lock.

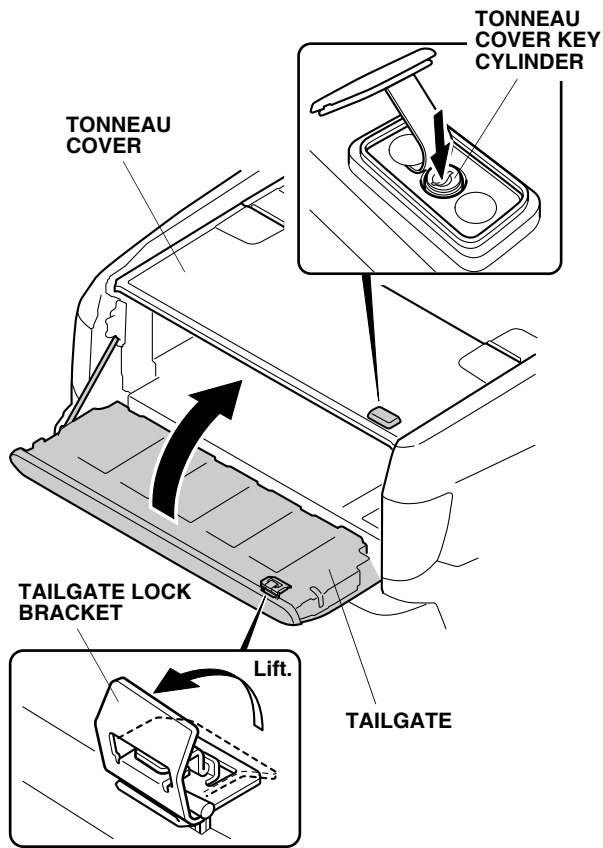

81. Lift the lock bracket and slowly close the tailgate.

82. Check the relation of the lock bracket to the lock striker.
- If the lock striker makes contact with the angled surface on the lock bracket (see Figure A), no adjustment is needed. Go to step 87.
  - If the lock striker hits the tip of the lock bracket (see Figure B), install shims as shown in the “Guide for installing the shims” included in the kit.

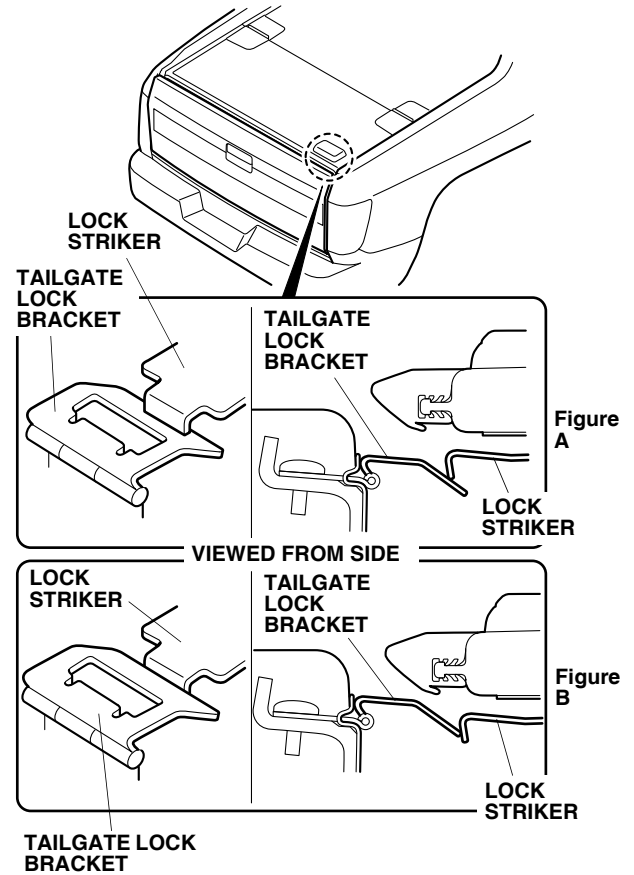

83. Turn the two knobs to unlatch the rear half of the tonneau cover. Fold it over the front half.
84. Using the alcohol pads, clean the areas where the shims will attach.

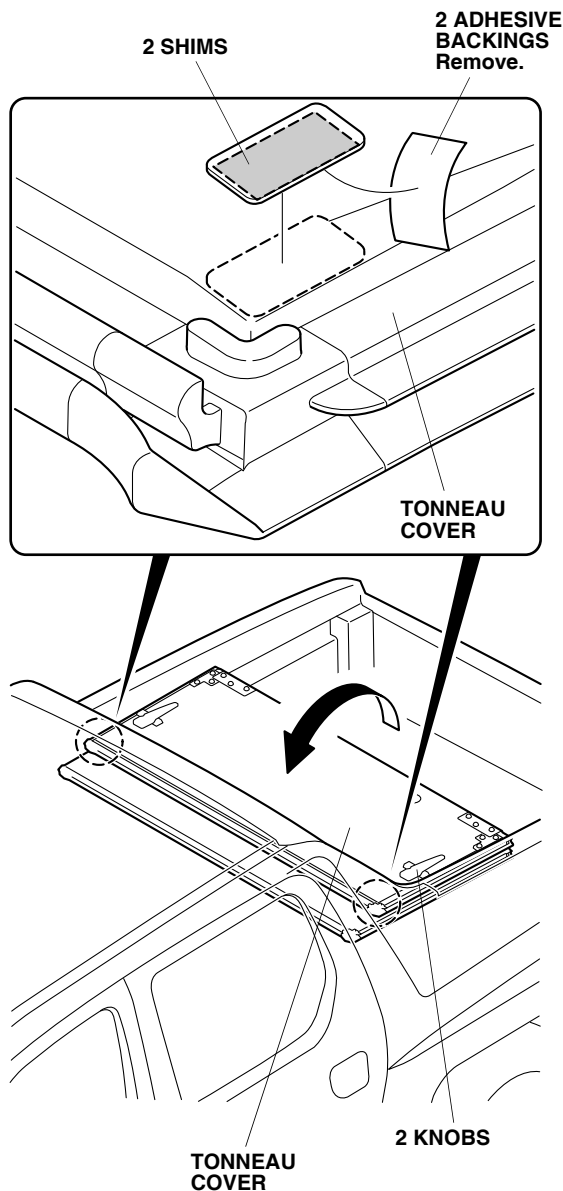

85. While wearing gloves, apply primer to the cleaned surface. Allow the primer to dry for at least 3 minutes before going to the next step.
86. Remove the adhesive backings from two shims, and attach them to the tonneau cover as shown.

## Reinstalling the Bed Rail Trims

87. With one hand on each end of the bed rail trim, hook the seven clips under the bed liner lip.

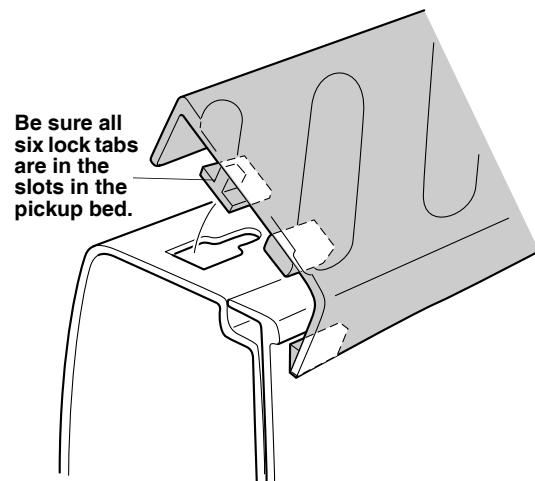
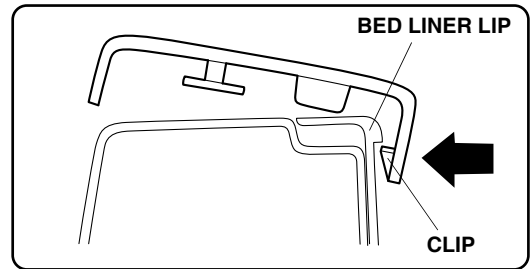

88. Roll the trim toward the outside of the bed rail. Make sure the trim lies flat on top of the bed rail, and that all six lock tabs are in the slots in the bed rail.
89. Place one hand on each end of the trim. Push down on the trim and slide it forward until you feel it stop. This locks all the tabs in place. Try lifting the outer edge of the trim along the full length to make sure all six tabs are locked in their slots.
90. Reinstall the mounting screw and the trim cap.
91. Reconnect the negative cable to the battery.
92. Reinstall all removed parts.
93. Enter the customer's radio anti-theft code, reset the radio station presets, and reset the clock.

**NOTE:** When the battery is disconnected, the driver's window AUTO function is disabled.

- Start the engine. Push down on the driver's window switch until the window is fully open.
- Pull up on the driver's window switch to close the window completely, then hold the switch for 1 second or more.
- Lower and raise the driver's window to check the operation of the driver's window AUTO function.