



INSTALLATION INSTRUCTIONS

Accessory

SPLASH GUARDS
P/N 08P00-TR0-100

Application

2012 CIVIC HYBRID

Publications No.

All 45624

Issue Date

APRIL 2011

PARTS LIST

Left front splash guard

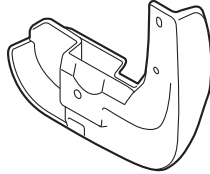

Right front splash guard

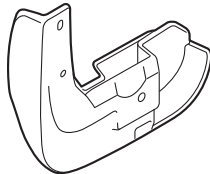

Left rear splash guard

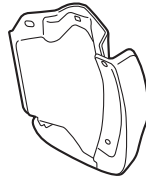

Right rear splash guard

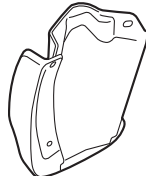

10 Self-tapping screws, 5 x 25 mm

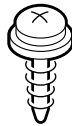

2 Spring nuts



2 Grommets A

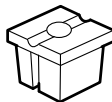

2 Grommets B



2 Self-tapping screws, 5 x 30 mm

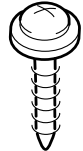

3 Clips

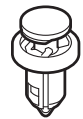

TOOLS AND SUPPLIES REQUIRED

Phillips screwdriver

Stubby Phillips screwdriver

Flat-tip screwdriver

Small flat-tip screwdriver

Trim Tool Set (T/N SOJATP2014)

(Available through the Honda Tool and Equipment program. On the iN, click on: Service/Service Bay/Tool and Equipment Program, then enter the number under "Search." Or call 888-424-6857.)

Drill

3 mm, 6 mm, and 10 mm Drill bits

File

Eye protection (face shield, safety goggles, etc.)

Pushpin

High-quality paste wax

INSTALLATION

Customer Information: The information in this installation instruction is intended for use only by skilled technicians who have the proper tools, equipment, and training to correctly and safely add equipment to your vehicle. These procedures should not be attempted by “do-it-yourselfers.”

NOTE:

- Be careful not to damage the body paint finish.
- These instructions show the left splash guards being installed. The same procedure applies to installing the right splash guards.
- Clean and wax the areas to be covered with a high-quality paste wax.

Installing the Front Splash Guards

1. Turn the steering wheel fully counterclockwise.

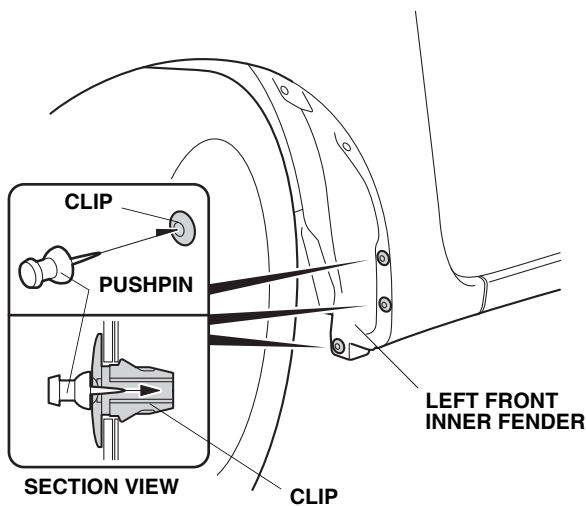

2. Using a pushpin, pierce the center of the three clips on the left front inner fender.

3. Secure the left front splash guard using three 5 x 25 mm self-tapping screws through the clips (pierced in step 2). Tighten the screws in the order shown.

NOTE: Check that there is no gap between the left front splash guard and the vehicle body. If there is a gap, loosen the three self-tapping screws, hold the splash guard against the body, and re-tighten the screws.

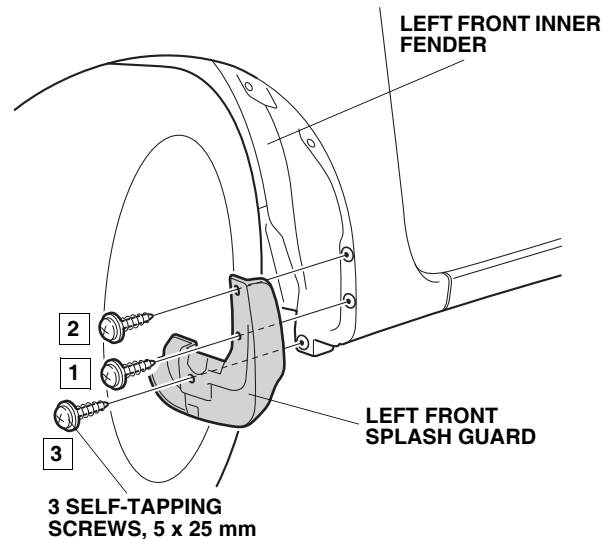

4. Turn the steering wheel fully clockwise, and repeat steps 2 and 3 to install the right front splash guard on the right side of the vehicle.

Installing the Rear Splash Guards

5. Locate the recessed mark on the left rear splash guard. Using a pushpin, pierce the splash guard at the recessed mark.

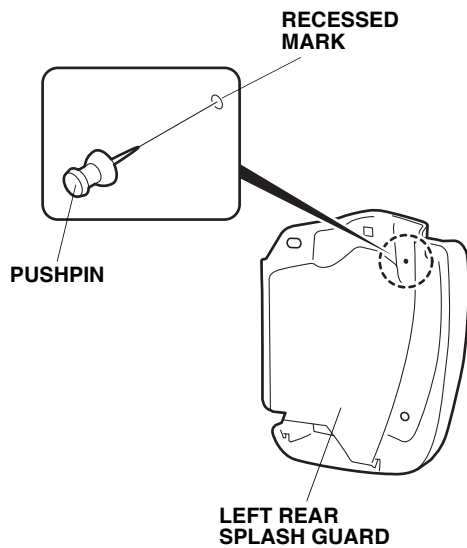

6. While wearing eye protection, drill the left rear splash guard at the pierced mark. First drill with a 3 mm drill bit, then with a 6 mm drill bit, and finish drilling using a 10 mm drill bit. Remove any burrs from the edges of the hole with a file.

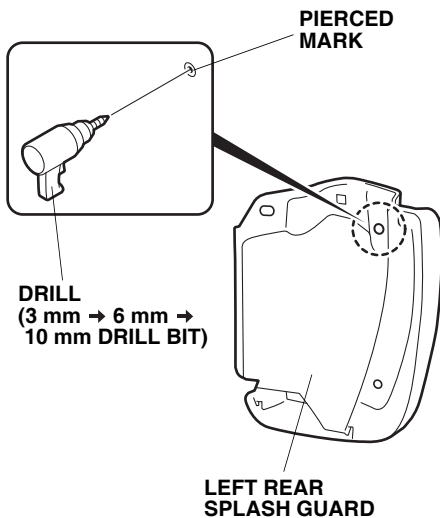

7. Remove four self-tapping screws that secure the rear bumper to the left rear inner fender. Discard the three screws shown, they will not be reused.

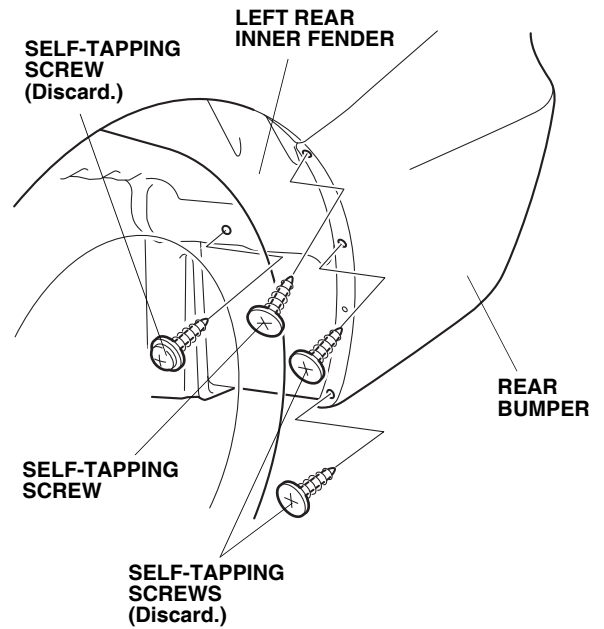

8. Remove and discard the lower clip from the inner fender cover.

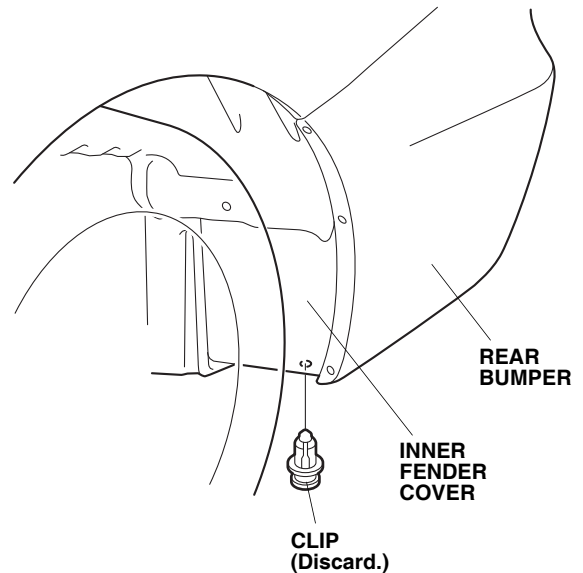

9. Gently pull the rear bumper away from the body, and release the seven retaining tabs.

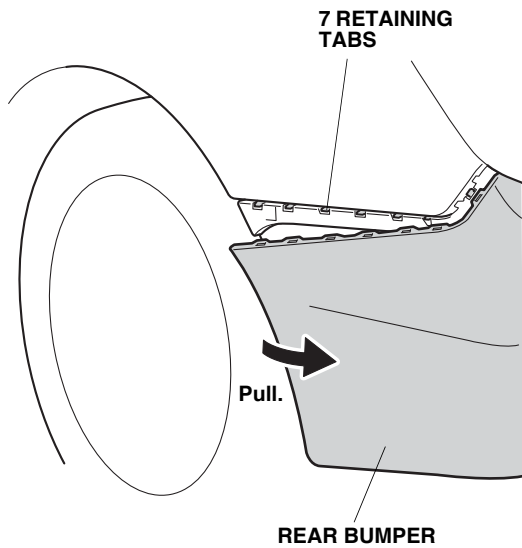

- Release the drain tube clip, and remove the inner fender cover. Set the inner fender aside, it will not be reused.

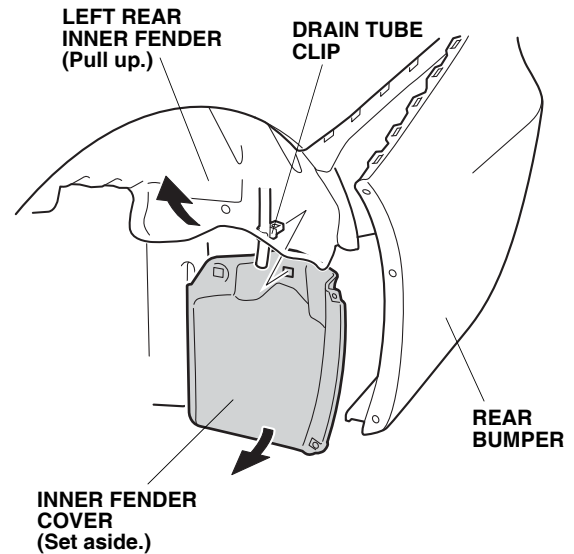

10. Remove the inner fender cover:
 - Pull the inner fender cover outward to loosen the clip.
 - Use a small flat-tip screwdriver to release the tabs on the clip, then remove the clip using a trim tool.

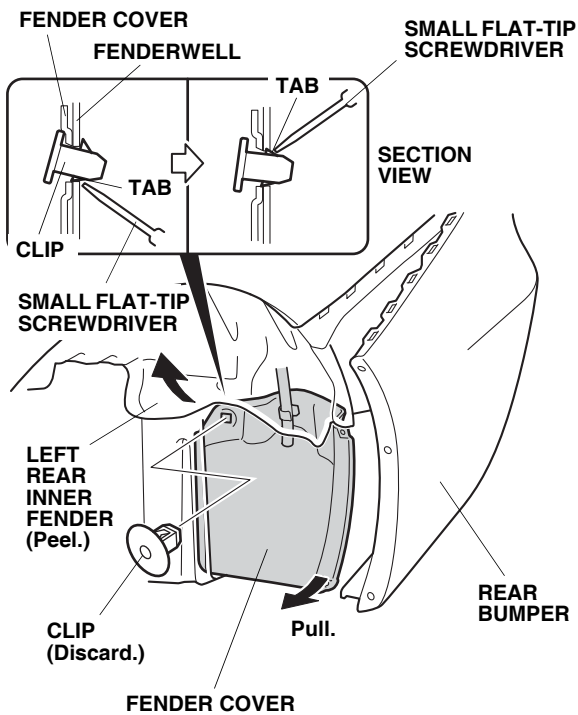

11. Pull away the left rear inner fender, and install one grommet A into the hole in the fenderwell.

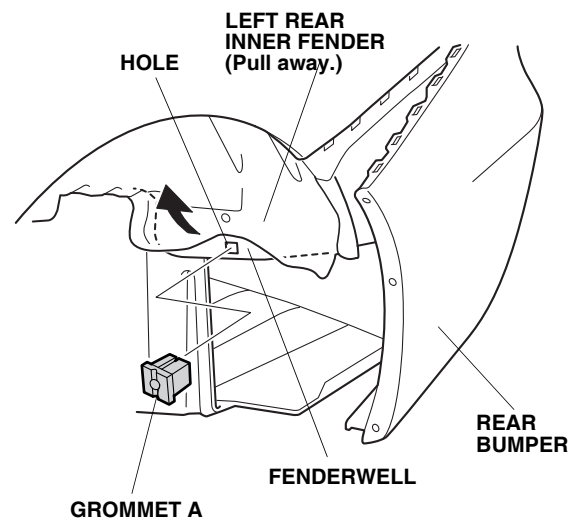

12. Install one grommet B into the hole in the fenderwell.

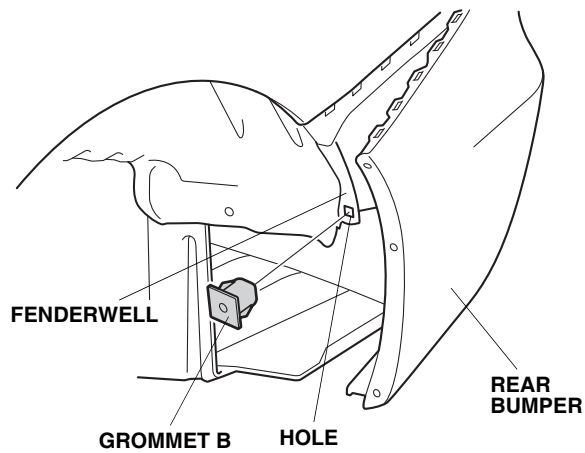

13. Reinstall the rear bumper onto the retaining tabs, and reinstall one self-tapping screw.

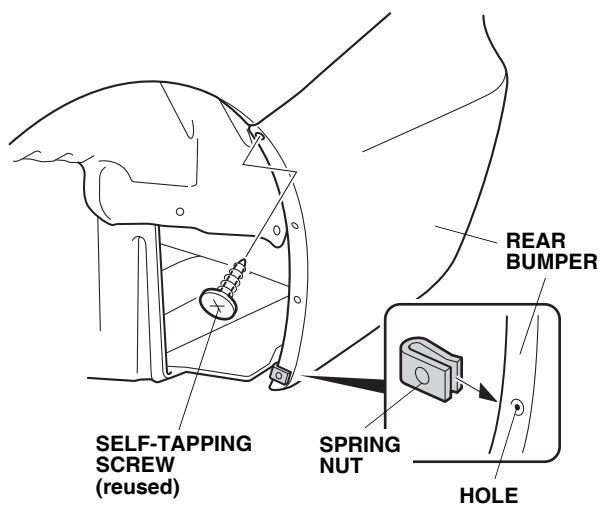

14. Install one spring nut over the lower hole in the rear bumper. Make sure to install the spring nut in the correct position and orientation.

15. Insert the left rear splash guard on the inside of the rear floor under cover, and the inside of the left rear inner fender. Then, install the drain tube clip to the left rear splash guard.

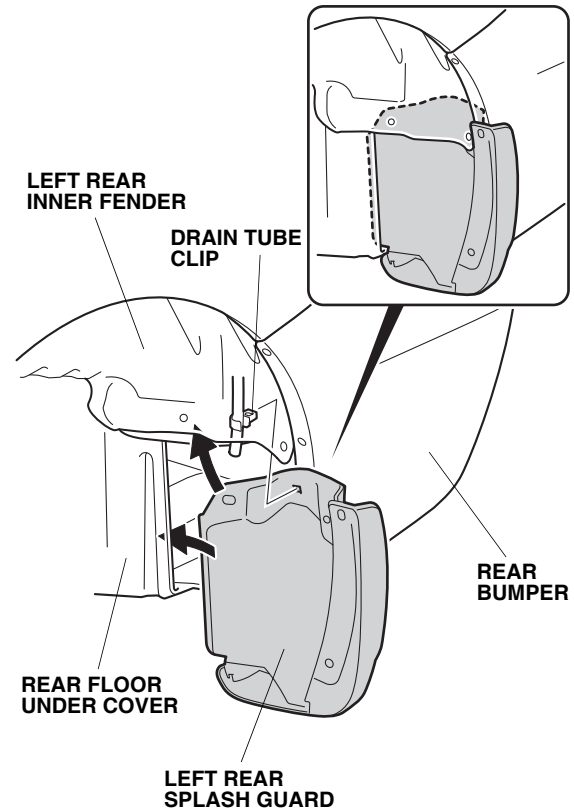

16. Secure the left rear splash guard using 5 x 25 mm self-tapping screws and one 5 x 30 mm self-tapping screw. Tighten the screws in the order shown.

NOTE: Check that there is no gap between the left rear splash guard and the vehicle body. If there is a gap, loosen the three self-tapping screws, hold the splash guard against the body, and retighten the screws.

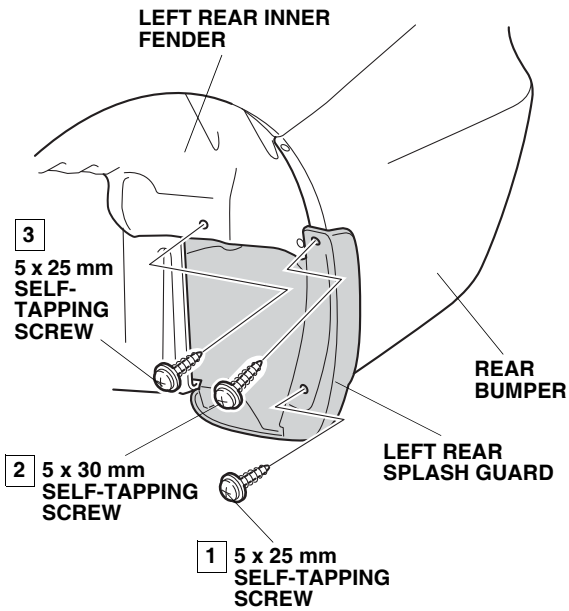

17. Secure the left rear splash guard with two new clips.
NOTE: The right rear splash guards do not use a lower clip.

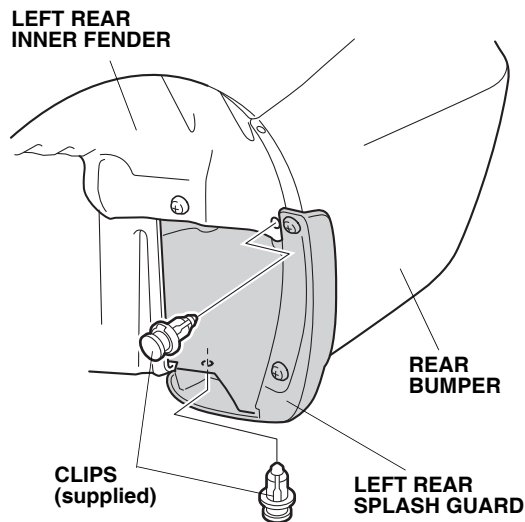

18. Repeat steps 5 through 17 to install the right rear splash guards on the right side of the vehicle.