



# INSTALLATION INSTRUCTIONS

Accessory

**SHIFT KNOB**  
P/N 08U92-S6M-200A (5 SPD)  
P/N 08U92-S6M-200B (6 SPD)

Application

**2005 ACCORD**  
**2-AND 4-DOOR**

Publications No.

**All 24057**

Issue Date

**JAN 2005**

## PARTS LIST

Shift knob

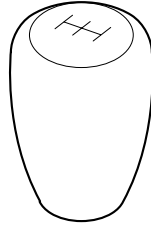

Flange nut



Wire tie

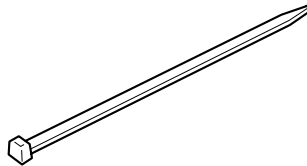

Collar

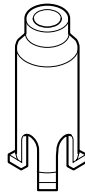

Ring

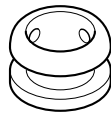

## TOOLS AND SUPPLIES REQUIRED

Phillips screwdriver

14 mm Combination wrench

Utility knife

Diagonal cutters

## INSTALLATION

1. Remove the trim ring:

- Squeeze the plastic clip, and pull down on the shift boot. Remove the shift knob by turning it counterclockwise.

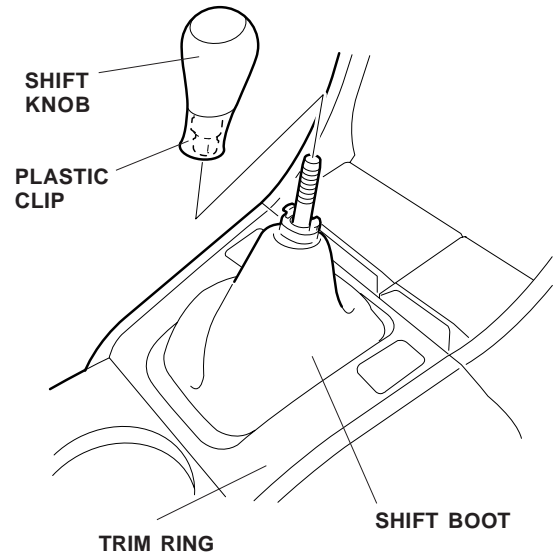

- Gently pry up on the trim ring to release the six clips.
- Unplug the two seat heater connectors (if equipped), and remove the trim ring.

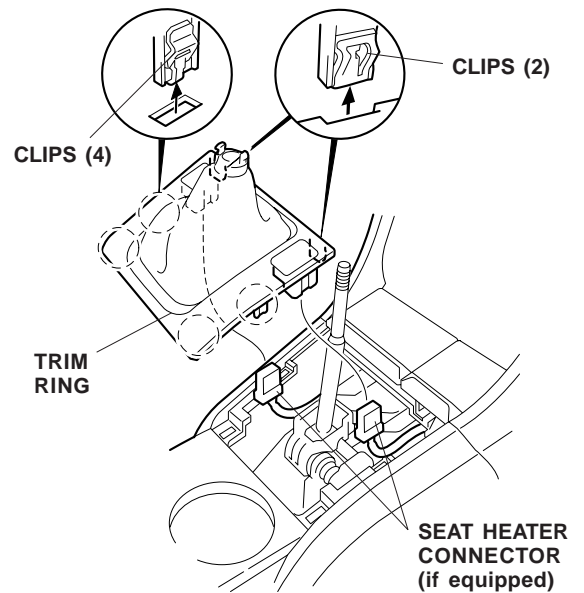

3. Push the boot so it's inside out.

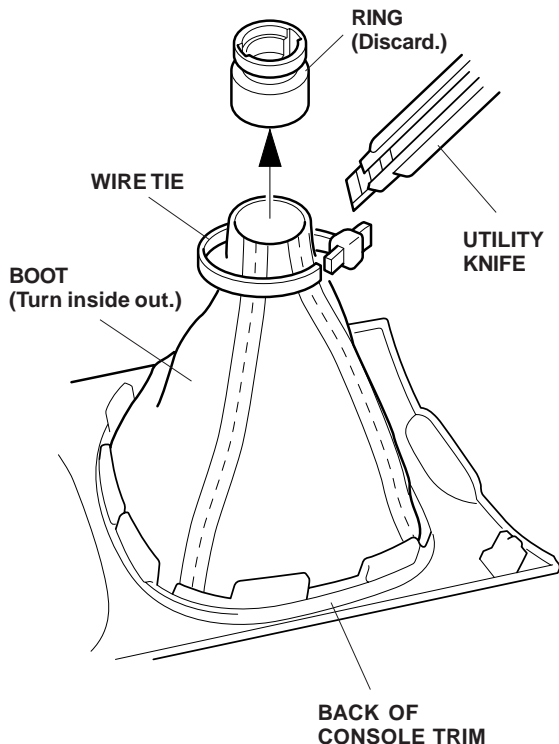

4. Using a utility knife, cut off the wire tie. Take care not to damage the boot when cutting the wire tie.
5. Insert the ring from the kit into the opening of the boot with the wrinkled leather end of the ring facing down.

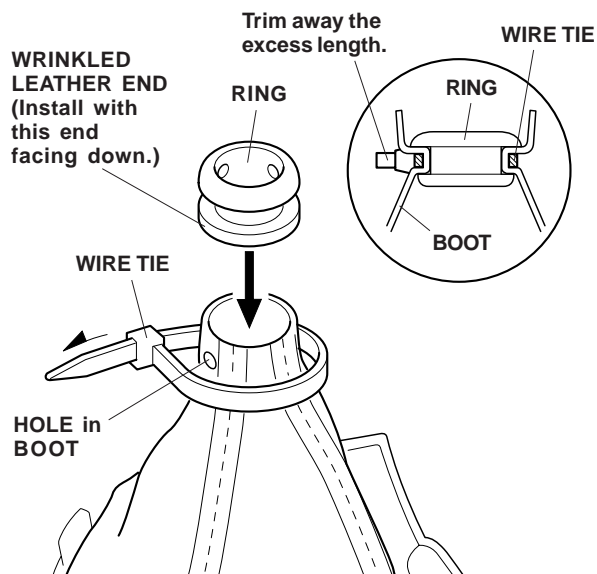

6. Secure the boot to the ring with the wire tie as shown.

7. Return the boot to its original position.

8. Fit the retaining tabs on the collar into the grooves on the ring by squeezing them with your hand. Check that the retaining tabs on the collar are set well into the ring grooves. To prevent damage to the retaining tabs, do not remove the collar once it is installed on the ring.

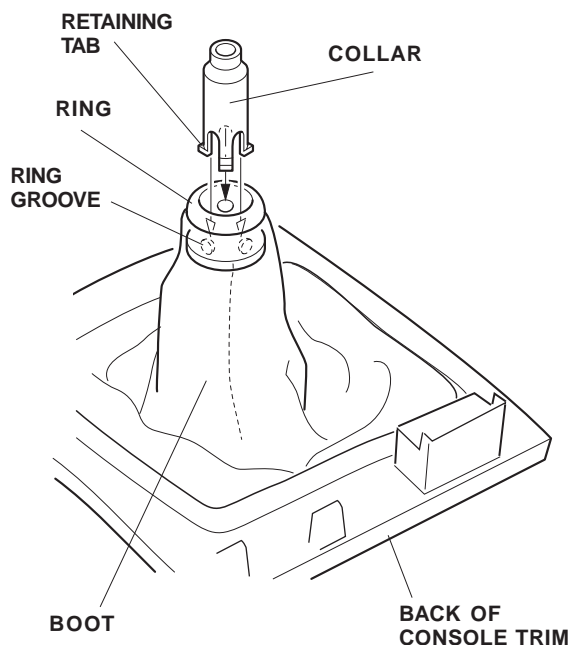

9. Reinstall the console trim.
10. Install the flange nut on the shift lever, flat side up, to the end of the threads.

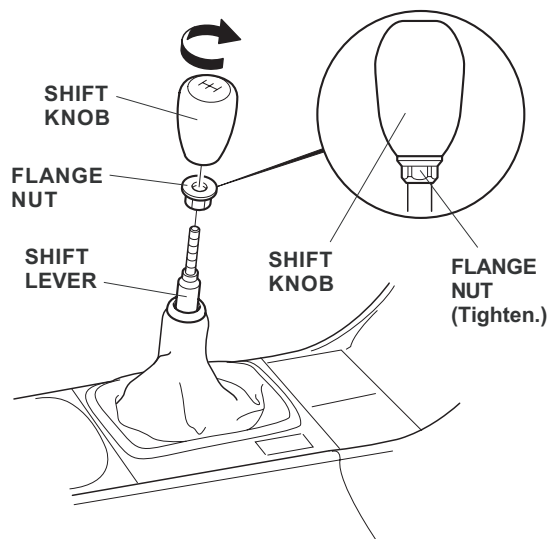

11. Install the shift knob on the shift lever until it is tight, then place it in the correct location, and tighten the flange securely.