



INSTALLATION INSTRUCTIONS

Accessory GOLD EMBLEM KIT	Application 2005 ACCORD 2-DOOR	Publications No. All 27591
		Issue Date OCT 2004

PARTS LIST

Gold Emblem Kit (sold separately):
P/N 08F20-SDN-100

Front gold "H" emblem

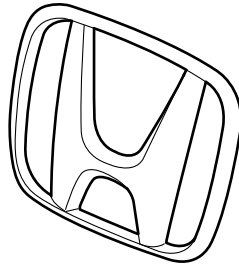

Rear gold "H" emblem

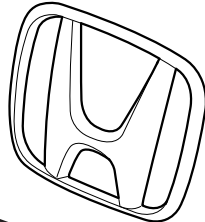

Rear gold
"ACCORD" emblem

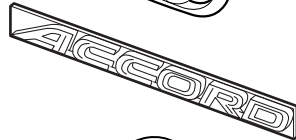

2 Push nuts



Rear Gold "V6" Emblem Kit (sold separately):
P/N 08F20-SDA-100A
P/N 08F20-SDN-100B

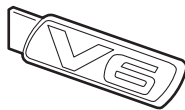

TOOLS AND SUPPLIES REQUIRED

- Phillips screwdriver
- Flat-tip screwdriver
- Ratchet
- 10 mm Socket
- Diagonal cutters
- Long nose pliers
- Isopropyl alcohol
- Shop towel
- String
- Masking tape
- Blanket

INSTALLATION

Customer Information: The information in this installation instruction is intended for use only by skilled technicians who have the proper tools, equipment, and training to correctly and safely add equipment to your vehicle. These procedures should not be attempted by "do-it-yourselfers."

NOTE:

- Be careful not to damage the body paint finish when removing and installing the emblems.
- This emblem kit should be installed only if the ambient air temperature is 60°F (15°C) or above.
- To allow the adhesive to "cure," do not wash the car for 24 hours.

Installing the Front Gold "H" Emblem

1. Open the hood. Remove the ten clips that fasten the radiator cover, and remove the cover by releasing the four retaining tabs.

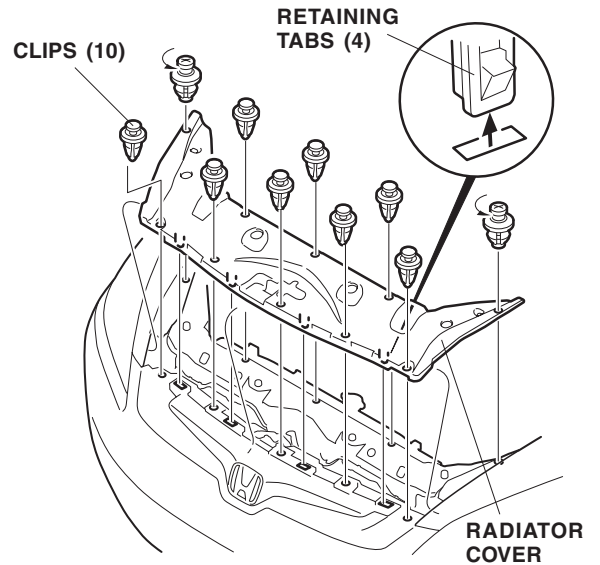

- Remove the six clips, four bolts and two self-tapping screws that fasten the front bumper, and remove the bumper.

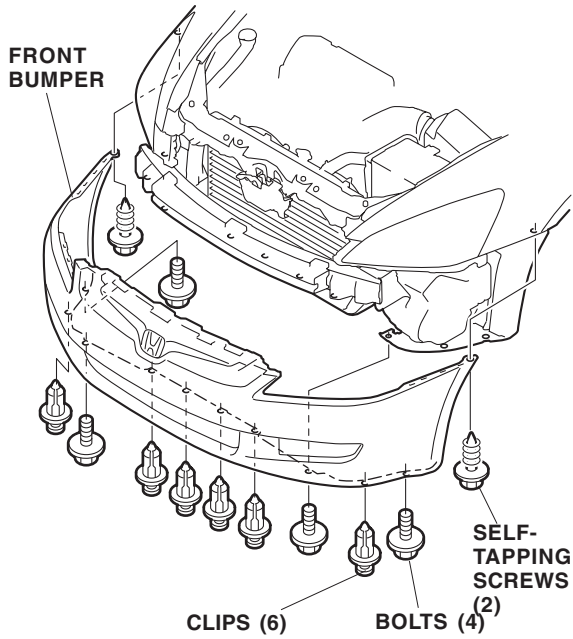

- Remove the four self-tapping screws that fasten the front grille to the front bumper, and remove the front grille.

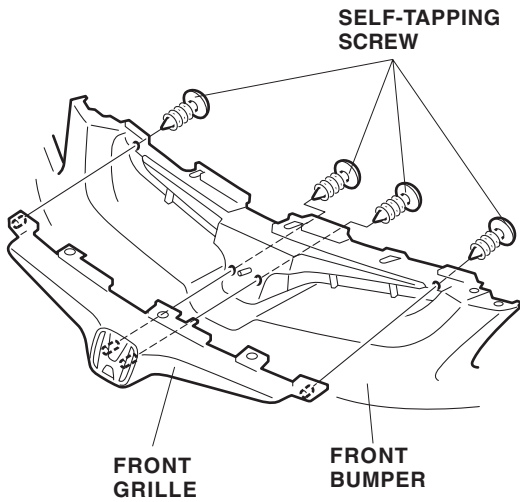

- Inside the front grille, cut off the two pins, and remove the push nuts and the old "H" emblem.

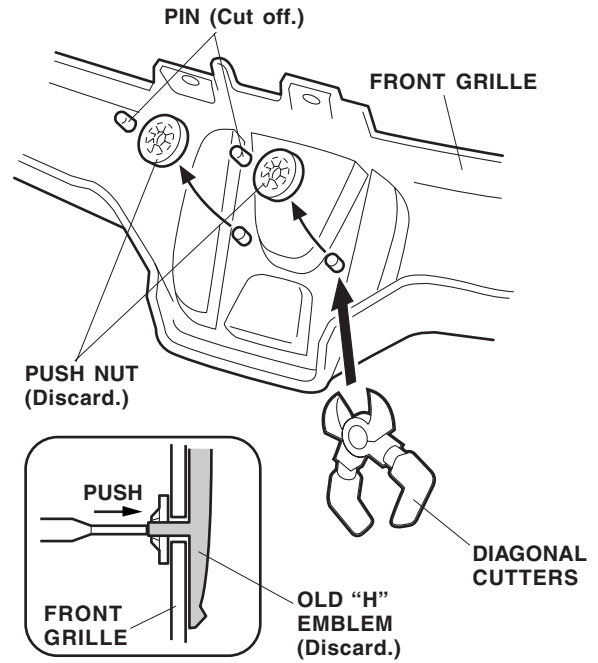

- Position the gold "H" emblem on the grille by aligning its pins with the holes in the grille.

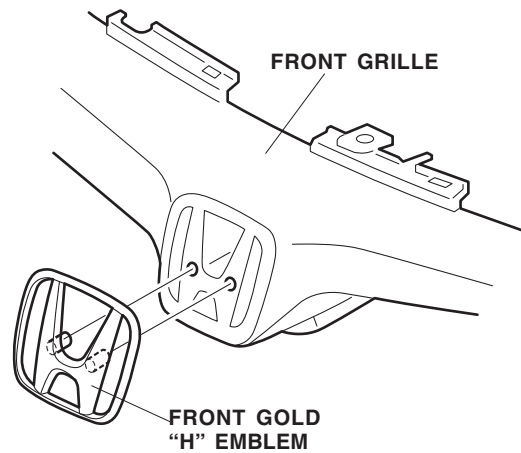

- Slide the push nuts flat-side first onto the pins. Note the direction of the push nuts.

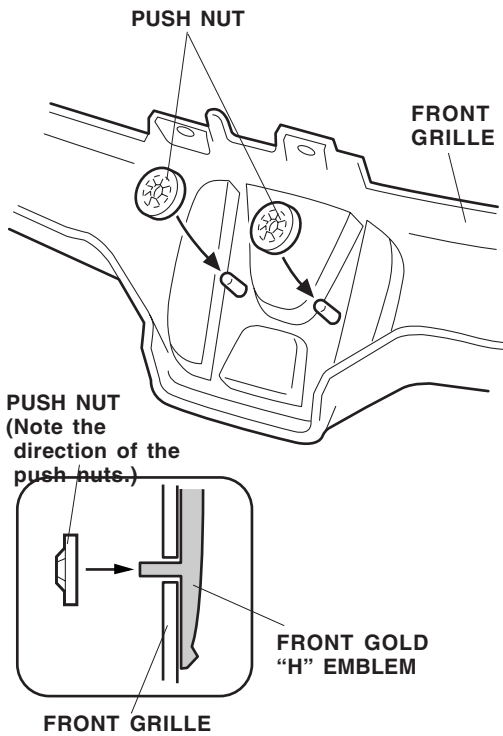

- Reinstall all removed parts. Check that the clips are installed securely.

Installing the Rear Gold "H," "ACCORD," and "V6" Emblems

- Mark the locations of the existing "H," "ACCORD," and "V6" emblems by applying masking tape along the edges as shown.

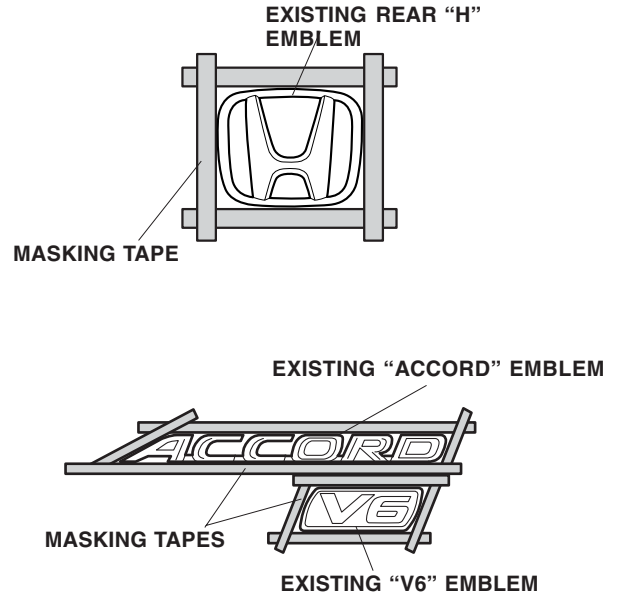

- Remove the "H," "ACCORD," and "V6" emblems from the body by moving the string back and forth, and working it between the emblems and body.

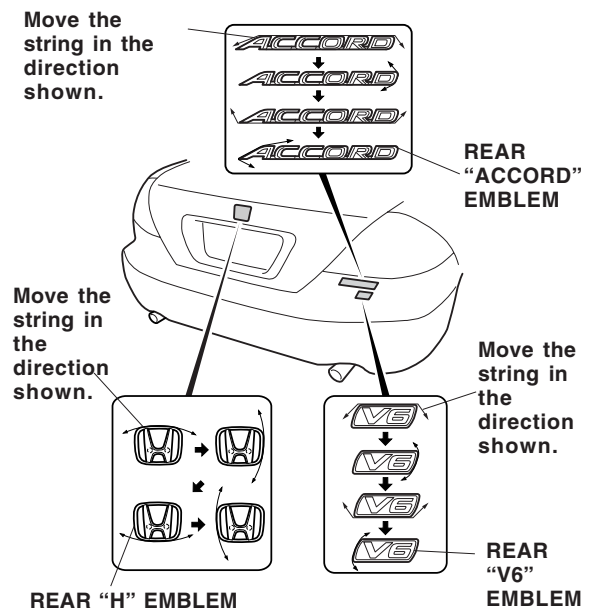

- Remove the emblems.

- If any clips for the "H" emblem remain on the vehicle body panel, remove the clips using long nose pliers.

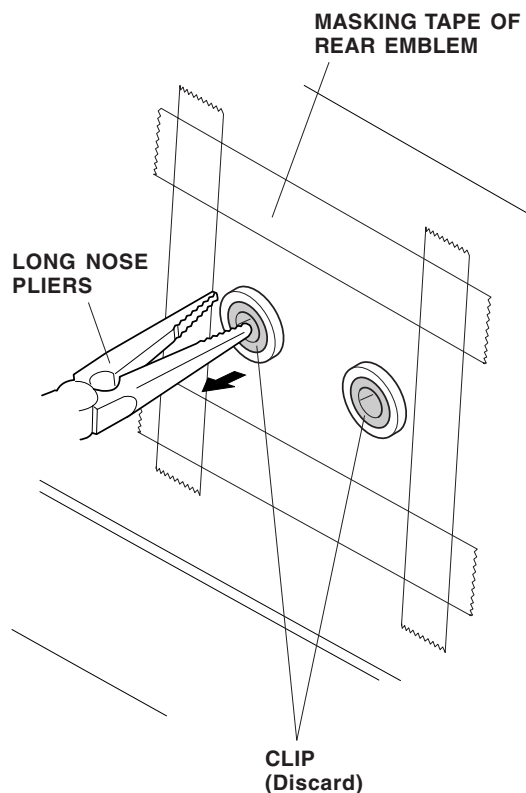

- Using isopropyl alcohol on a shop towel, clean the areas where the gold "H," "ACCORD," and "V6" emblems will attach.

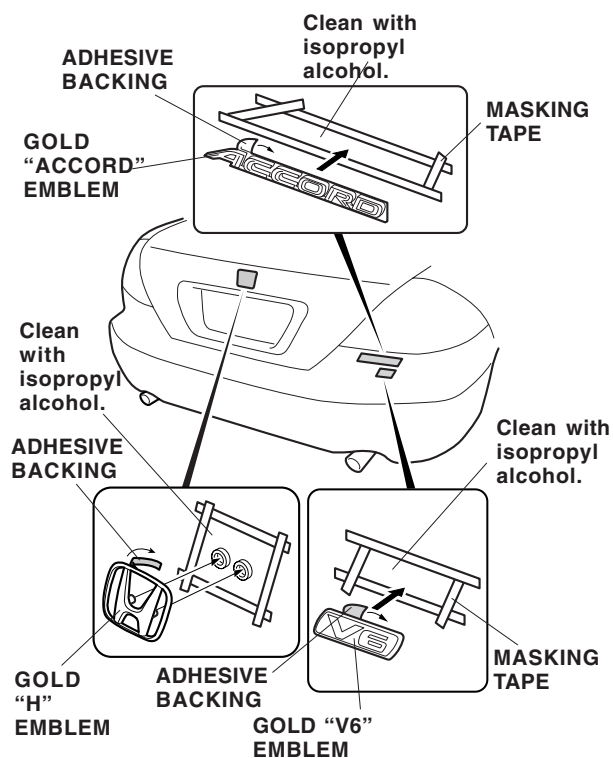

- Remove the adhesive backing from the "H," "ACCORD," and "V6" emblems, and attach them to the body. After attaching, hold the emblems firmly against the body with the palm of your hand for at least 30 seconds.
- Remove the masking tape.