



INSTALLATION INSTRUCTIONS

Accessory

**BICYCLE ATTACHMENT
(ROOF MOUNT)
P/N 08L07-TA1-102**

Application

**2005 ACCORD
HYBRID**

Publications No.

All 27710

Issue Date

DEC 2004

Put this information in the glove box with the vehicle owner's manual.

PARTS LIST

Bike attachment

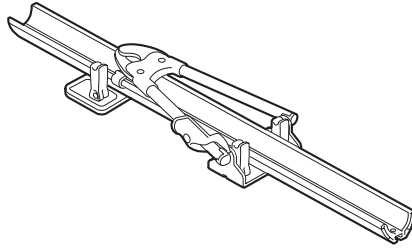

5 mm Allen wrench

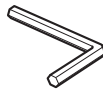

2 Keys



Owner's Manual

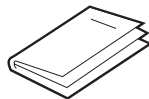

2 Wheel straps

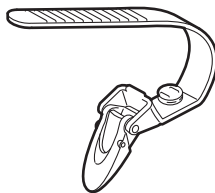

2 Tire adapters



2 End caps



TOOLS REQUIRED

Phillips screwdriver

INSTALLATION

NOTE:

- Be careful not to damage the painted surfaces of the vehicle when installing the bike attachment.
- If you are installing more than one bike attachment, you may need to alternate the mounting positions (front to rear) to allow for handlebar clearance.
- Make sure the security retainer and the locking clamp lever are installed on the outboard side. See the Owner's Manual supplied for details.
- The crossbars have a directional positioning. The short portion in front of the channel should face toward the front of the vehicle.
- These instructions show the bicycle attachment being installed on the passenger's side of the vehicle; use the same procedure to install the bicycle attachment on the driver's side of the vehicle.

Preparing the Bicycle Attachment

- Slide the rear plate forward, and remove the rear plate from the bicycle attachment.

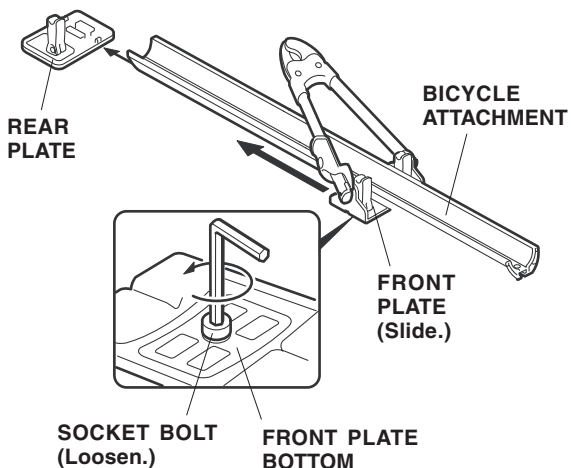

- Using the 5 mm Allen wrench, loosen the socket bolt at the bottom of the front plate, and slide the front plate forward to the position shown.
- Reinstall the rear plate to the bicycle attachment on the opposite end of the channel.

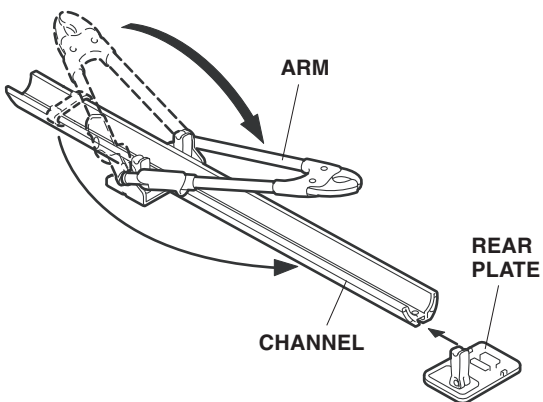

- Remove the rubber bumper from the channel, and transfer it to the new location on the channel. Rotate the arm to rest against the rubber bumper.

- Adjust the front plate to 305 mm from the end of the channel, and retighten the socket bolt.

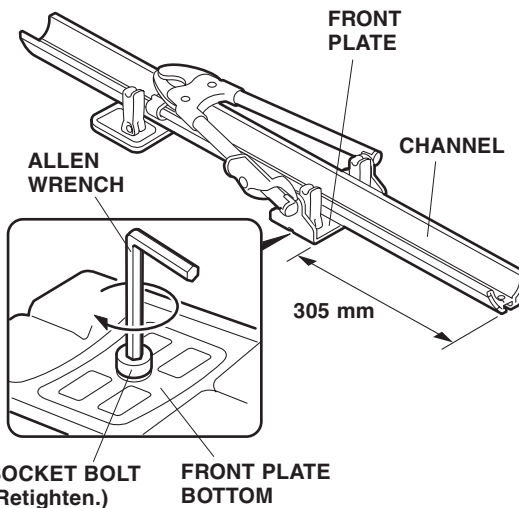

- Slide the tire adapter onto the wheel strap, and slide a wheel strap onto one end of the bicycle attachment channel. Repeat on the other end. Make sure both wheel strap buckles are on the same side. Adjust the direction of the tire adapter according to the size of the tire.

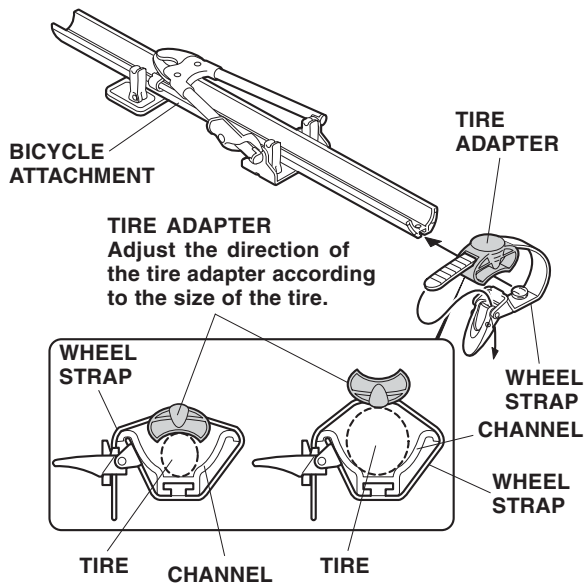

7. Install an end cap on the bicycle attachment channel by aligning the lock tab on the end cap with the hole in the channel. Push down on the end cap until the lock tab "clicks" into place. Repeat on the other end.

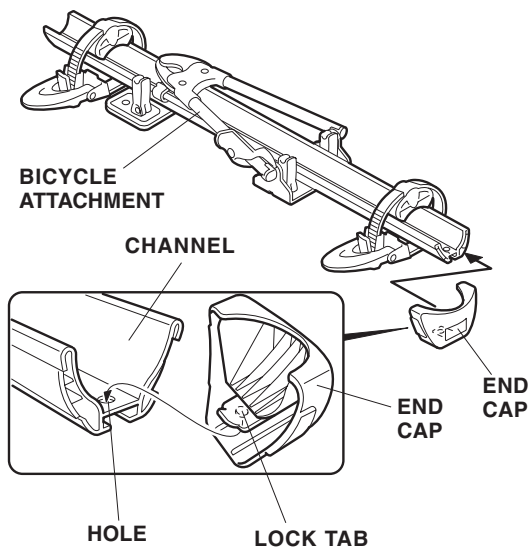

Installing the Bicycle Attachment on a Removable Roof Rack

8. Remove the three mounting levers and T-bolts from the bicycle attachment, and set them aside to be installed later.

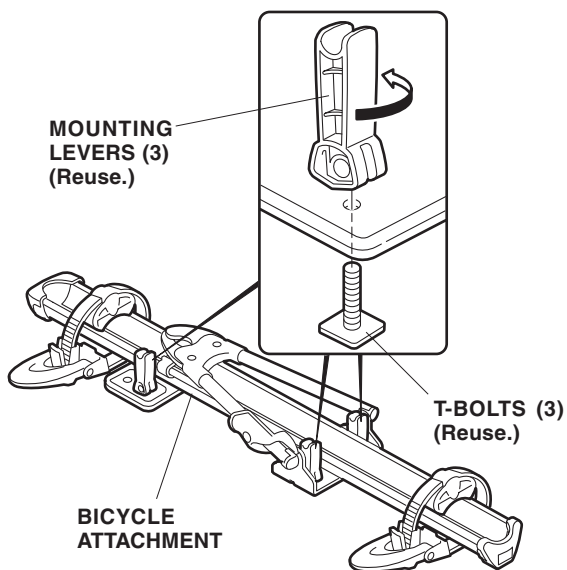

9. Pull out on the end cap of the carrier bar, and open the T-track access cover.

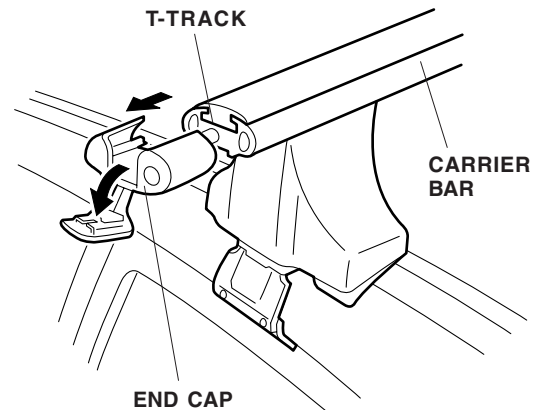

10. Remove the rubber moldings from the T-tracks of the front and rear carrier bars. Retain the rubber moldings to be installed later.

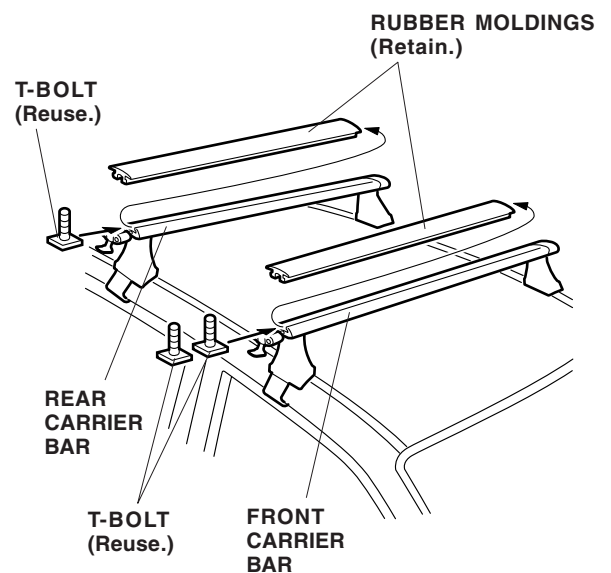

11. Slide two T-bolts into the front carrier bar, and slide one T-bolt into the rear carrier bar.

- Position the bicycle attachment over the T-bolts on the carrier bars, and install the mounting levers removed in step 8. Do not tighten or lock the mounting levers at this time.

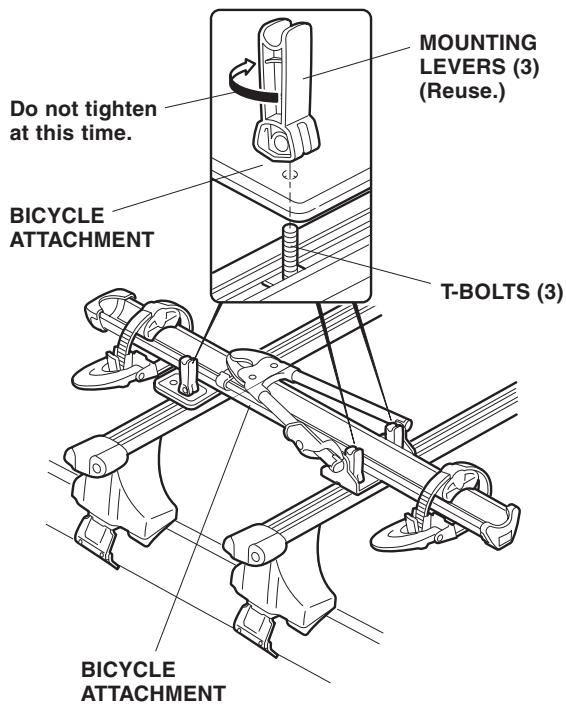

Attaching the Bicycle Attachment

- Open the locking clamp lever.

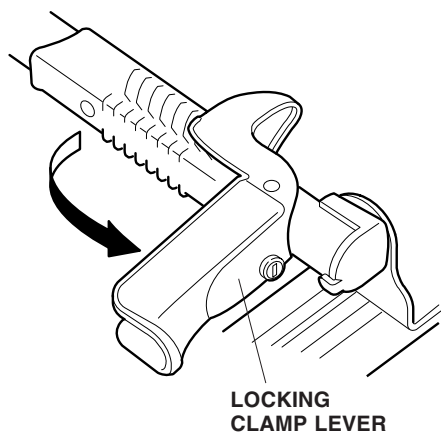

- Turn and adjust the mounting lever to lock the bicycle attachment to the roof rack. Check for firm pressure while you push down on the mounting lever to lock it into place.

- If the mounting lever pressure is too tight (the lever will not lock into place), lift up on the lever and turn it counterclockwise.
- If the mounting lever pressure is too loose (the lever locks into place, but the bicycle attachment is loose on the crossbars), lift up on the lever and turn it clockwise.

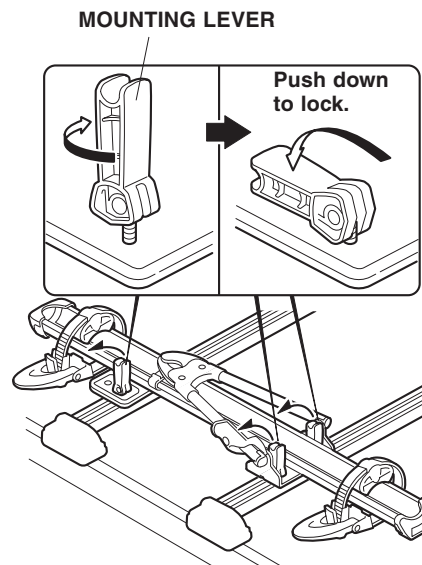

- Close the locking clamp lever. To deter theft of the bicycle attachment, lock the locking clamp lever with the key.

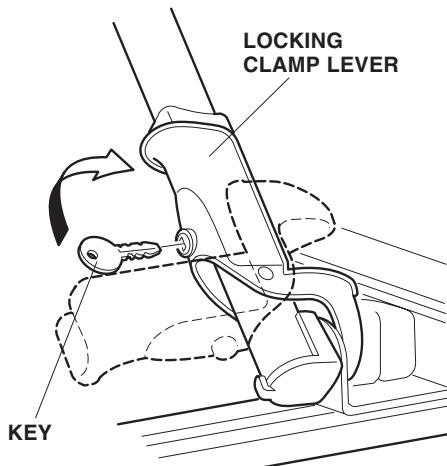

- Put this instruction and the Owner's Manual in the glove box.
- Put the keys in the glove box.
- Using scissors, cut the rubber moldings (retained in step 10), and insert the cut pieces into the T-tracks of the front and rear carrier bars.

Installing a Bicycle onto the Bike Attachment

NOTE: Do not carry a bicycle on this attachment if the diameter of the bicycle frame exceeds 55 mm or if the sectional view is not circular in the area where it is held by the bicycle holder.

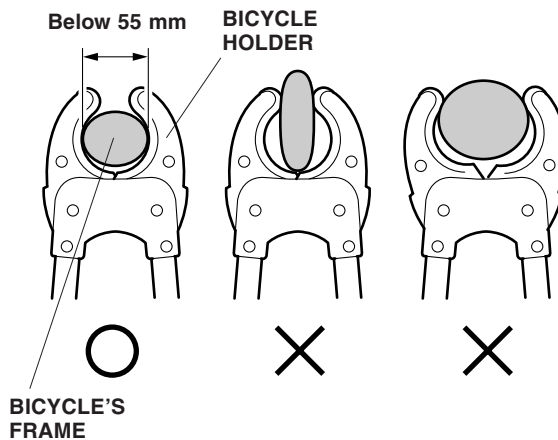

- Release the locking clamp lever with the key, and pull the locking clamp lever down.

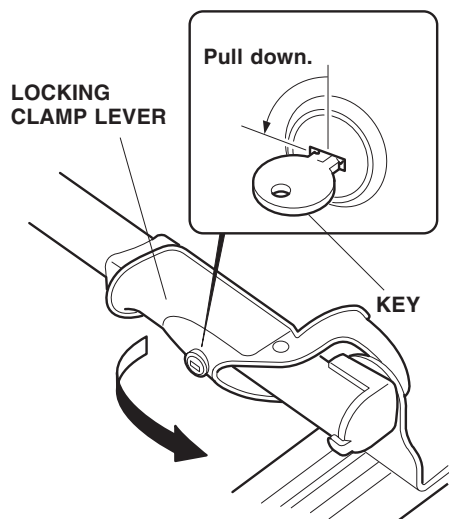

20. Position the bicycle on the channel. Lift the arm up, and hold the bicycle's frame by the holder to push down on the slider.

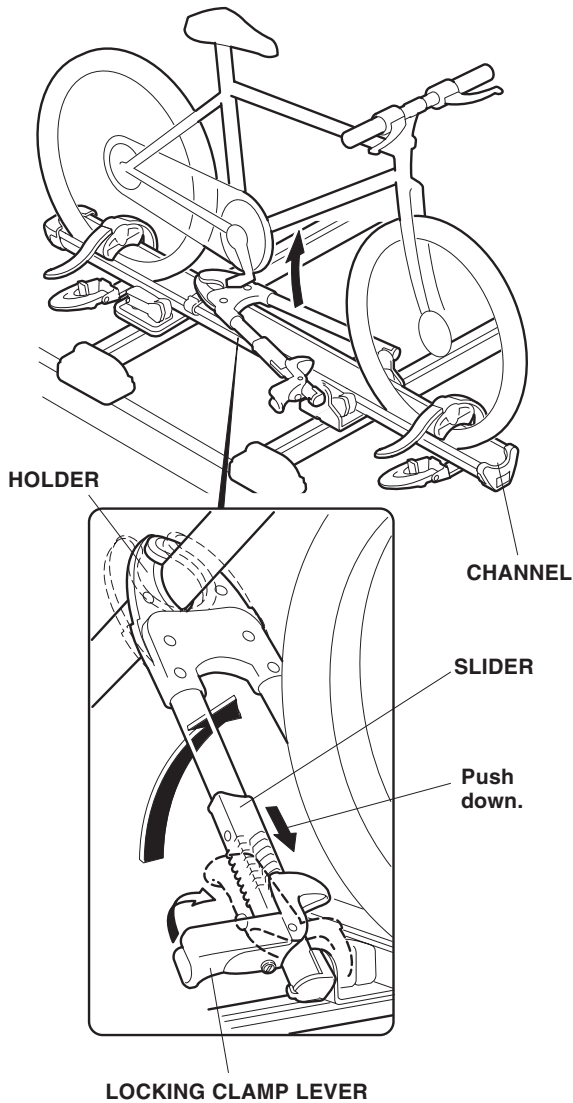

22. Push up the locking clamp lever to secure the bicycle's frame.

23. Lock the locking clamp lever by inserting the key in the key cylinder and turning it clockwise.

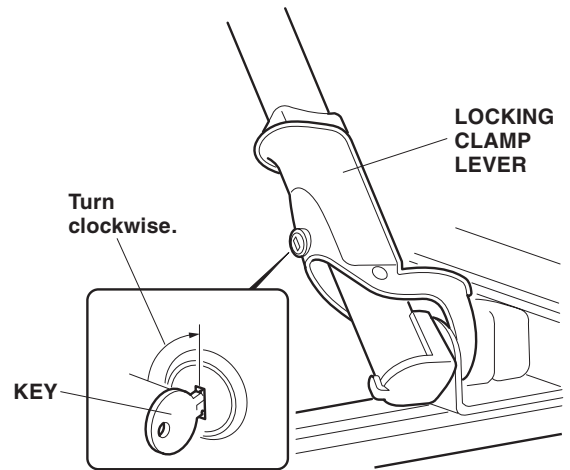

24. Position wheel straps at the center of the bicycle's wheels; then secure the wheels with the wheel straps by inserting the belts through the buckles, and folding the buckles in the direction shown.

NOTE: If the tires are so small that they cannot be secured by the belts, reinstall the tire adapters upside down on the belts.

