



INSTALLATION INSTRUCTIONS

Accessory
SKI ATTACHMENT
P/N 08L03-TA1-100A

Application
2005 ACCORD HYBRID

Publications No.
All 27732
Issue Date
DEC 2004

Put this information in the glove box with the vehicle owner's manual.

PARTS LIST

2 Ski attachments

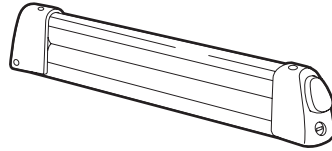

4 Knobs



4 Short T-bolts (for removable rack)

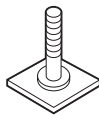

4 Long T-bolts (not used)

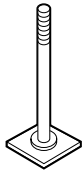

4 Block spacers (not used)

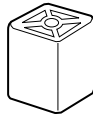

Key



TOOLS REQUIRED

Phillips screwdriver

T-30 Torx bit

Ratchet

INSTALLATION

NOTE:

- The ski attachments are designed to be used exclusively with a Honda accessory roof rack, which is sold separately. If the vehicle is not equipped with a roof rack, install the recommended roof rack before installing the ski attachment.
- The ski attachments may be installed either with both on the driver's side, or with both on the passenger's side.

- Pull out on the end cap to open the crossbar access cover for both crossbars.

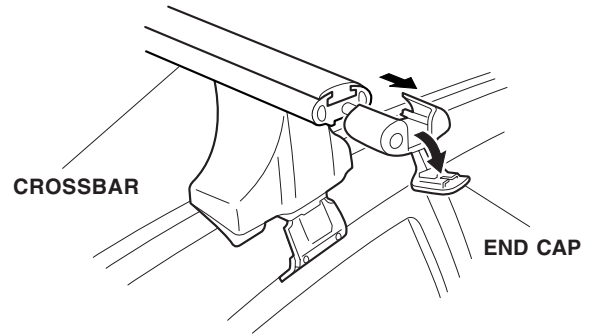

- Remove the rubber moldings from the front and rear crossbars. Retain the rubber moldings to be installed later.
- Open the end cap, and slide two short T-bolts into each crossbar (front and rear). Close the end cap.

RUBBER MOLDING

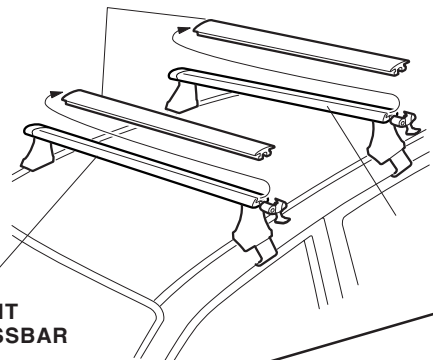

REAR CROSSBAR SHORT T-BOLT

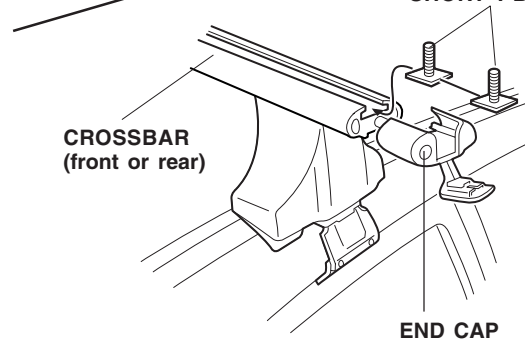

4. Insert the key, and turn it clockwise to unlock the front ski attachment. Press the button, and open the top frame completely.

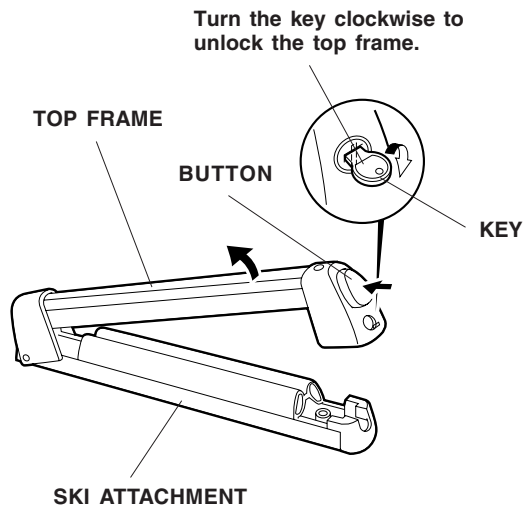

5. Position the ski attachment onto the short T-bolts, and install the two knobs. Tighten the knobs securely.

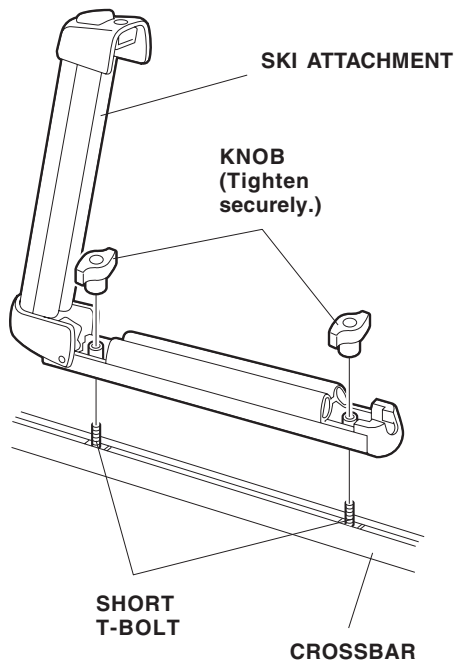

6. Repeat steps 4 thru 6 to install a ski attachment onto the rear crossbar.

7. Close the top frame, and listen for it to click into position; then turn the key counterclockwise to lock the top frame.
8. Rock the ski attachments in all directions to make sure they are installed securely. If necessary, retighten the T-bolts or reinstall the ski attachments.
9. To prevent excess wind noise, cut each rubber molding, and install the cut pieces into the grooves in the crossbars.
10. Write down the key number to be put it in a safe place in case the key is lost or stolen.
11. Put the key number, the key, and the rubber moldings removed in steps 2 and 8, into a clear plastic bag for the customer.

Loading the Skis on the Vehicle

1. Insert the key, and turn it clockwise to unlock the top frame. Push the button, and raise the top frame completely.

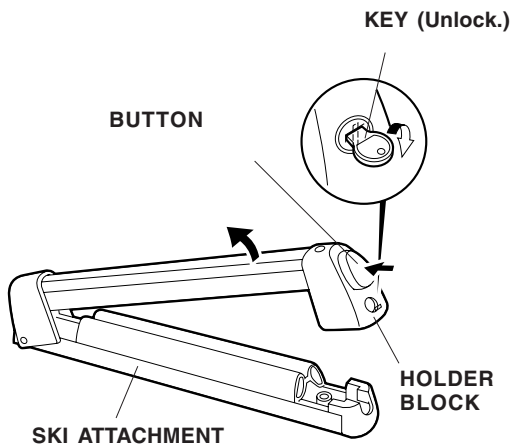

2. Position the skis on the attachment:
 - Load with the rear of the skis facing forward and the bindings between the front and rear attachments.

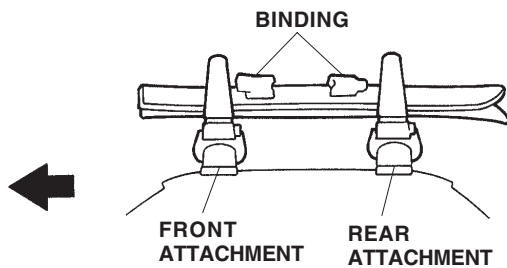

- If the bindings cannot be positioned between the front and rear attachments, install the skis with one of the bindings positioned behind the rear attachment.

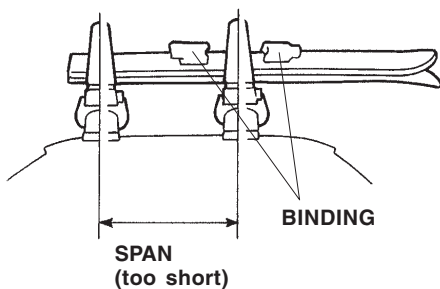

3. Close the top frame, and listen for it to click into position. Depending on the thickness of the ski, you may need to attach the hook in the second position.

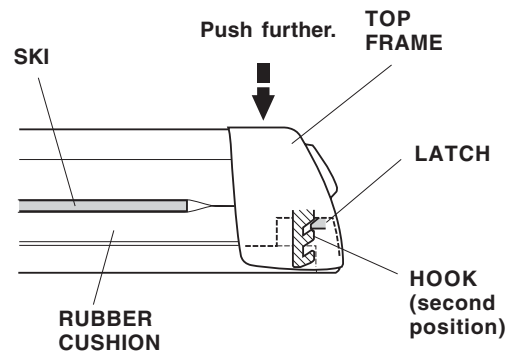
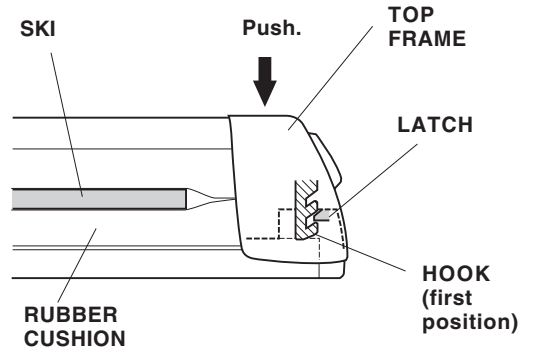

4. Lock the top frame by turning the key counterclockwise. Remove the key.

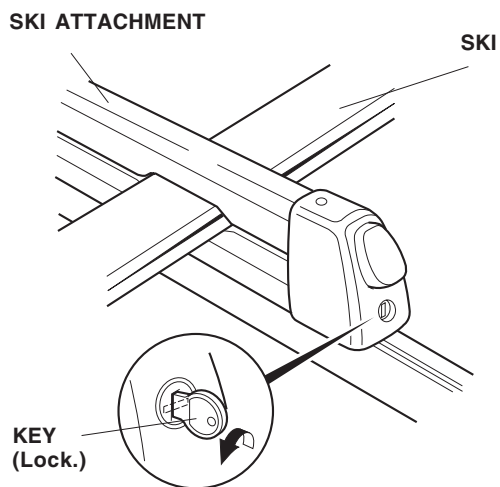

5. With the ski attached, rock the attachment in all directions to make sure it is installed securely. Adjust as necessary.

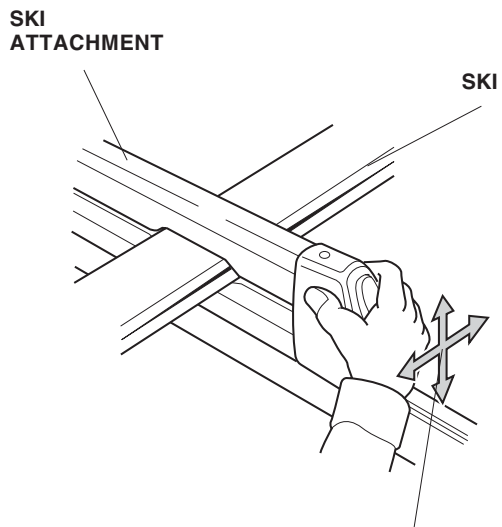

Rock the ski attachment in all directions to make sure it is installed securely.