

**PARTS LIST**

Front under spoiler

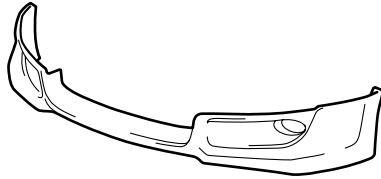

Template A

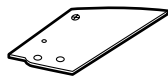

Template B

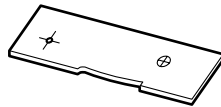

6 Bumper bolts



6 Flange nuts



4 Self-tapping screws, 5 x 18 mm



4 Spring nuts

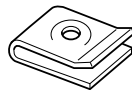

4 Clip retainers



4 EPDM sponges



2 Clips

**TOOLS AND SUPPLIES REQUIRED**

Phillips screwdriver

Clip remover

Eye protection (face shield, safety goggles, etc.)

Drill

3 mm, 10 mm, and 12 mm Drill bits

16 mm Holesaw

Rubber roller (EQSE54D)

File

Pushpin

Touch-up paint

Ratchet

10 mm Socket

Gloves

Masking tape

Shop towel

Isopropyl alcohol

Reciprocating Saw (snap-on tool #AT192A)

Tape

## INSTALLATION

**Customer Information:** The information in this installation instruction is intended for use only by skilled technicians who have the proper tools, equipment, and training to correctly and safely add equipment to your vehicle. These procedures should not be attempted by “do-it-yourselfers.”

### NOTE:

- Can not install with nose mask.
  - Using isopropyl alcohol on a shop towel, thoroughly clean the area where the front under spoiler will be attached. Allow the isopropyl alcohol to dry thoroughly before attaching the front under spoiler.
  - Be careful not to damage the body paint finish.
  - This front under spoiler kit should be installed only if the ambient air temperature is 15°C (60°F) or above.
  - Wash and wax the area to be covered with a high-quality paste wax.
  - To allow the adhesive to cure, do not wash the vehicle for 24 hours.
1. Remove the seven clips from the front bulkhead cover.

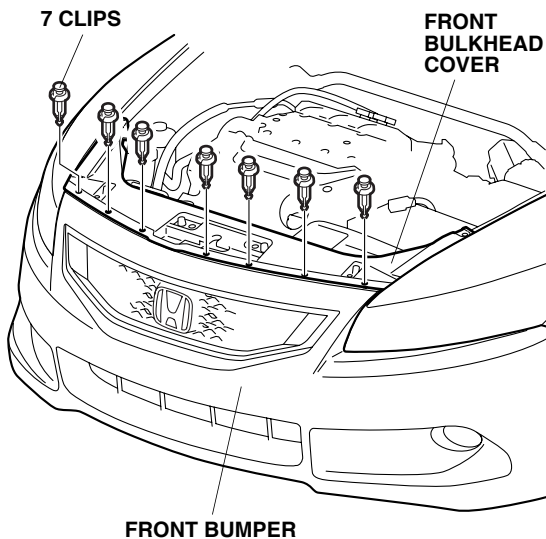

2. Remove the front bumper (two self-tapping screws and ten clips and disconnect the fog light connectors (if equipped)).

**NOTE:** Have an assistant help you to remove and install the front bumper

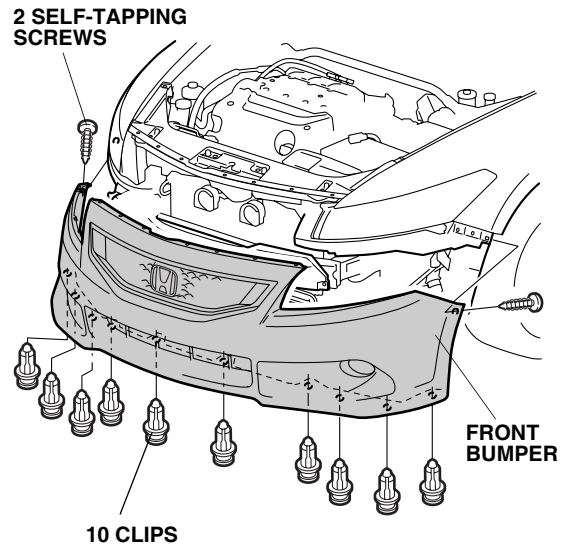

- Remove the three self-tapping screws from the front bumper, and remove the left fog light cover, or foglight cover/fog light. Remove the right fog light cover the same way.

**Without Fog Lights**

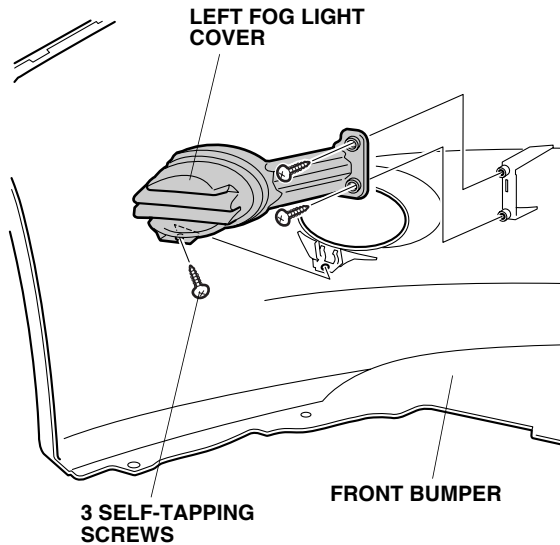

**Without Fog Lights**

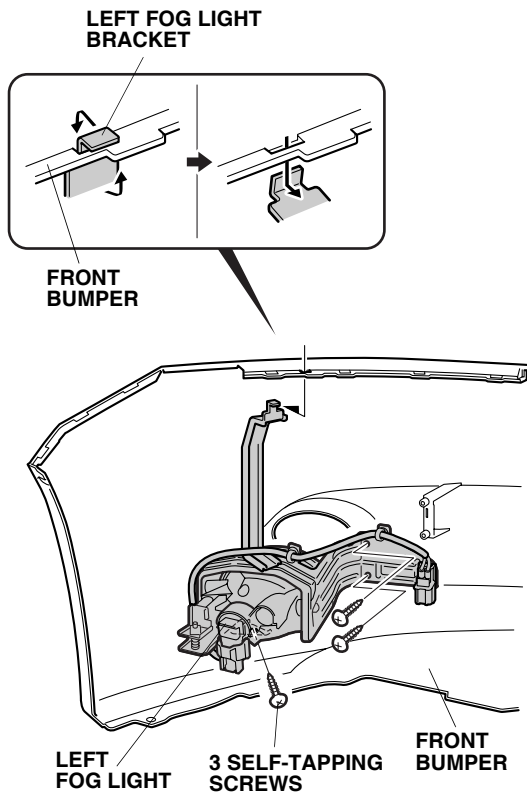

- Place template B on the front bumper as shown. Using a pushpin, mark the front bumper. Remove the template B.
- While wearing eye protection, drill a 3 mm hole through the mark from the front bumper as shown. Finish with a 12 mm bit. Remove all burrs.
- Reverse the template B and repeat the steps 4 and 5 on the right side.

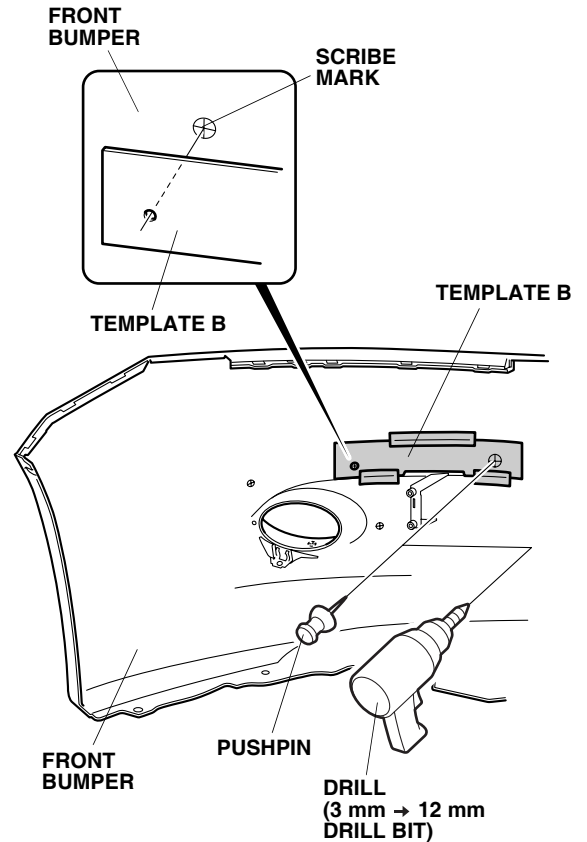

7. Inside the front bumper, locate the five scribe marks in the area shown, and punch the cross sections of the five scribe marks with a push pin.
8. Drill a 3 mm hole through the marks from the front bumper as shown.
9. Drill a 10 mm hole through the two marks from the front bumper as shown.
10. Using 16 mm holesaw drill through the two marks from the front bumper as shown.

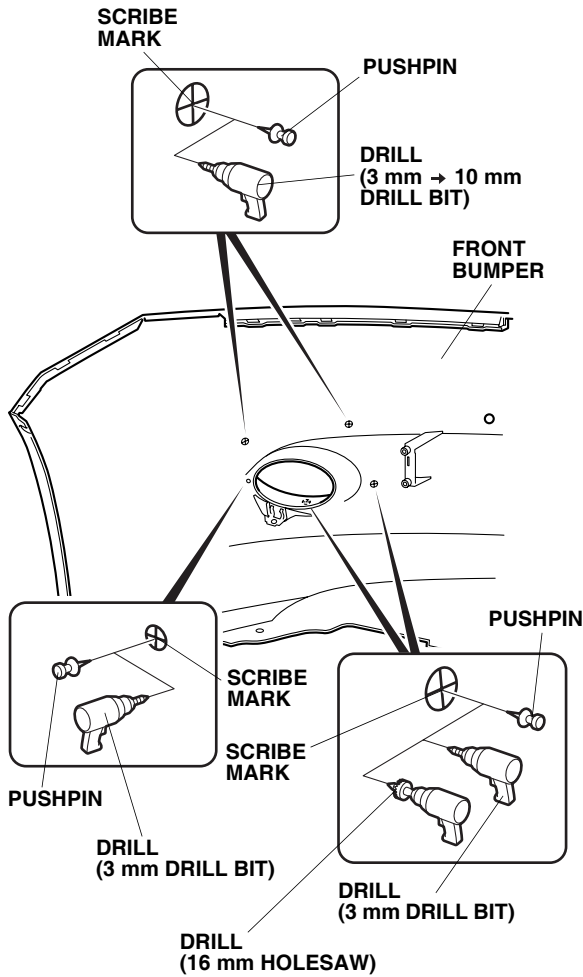

11. Attach the tape to the front bumper as shown.
12. Using an reciprocating saw, cut out the marked area of the front bumper in the area shown. Remove all burrs.
13. Repeat the steps 7 through 12 on the right side.

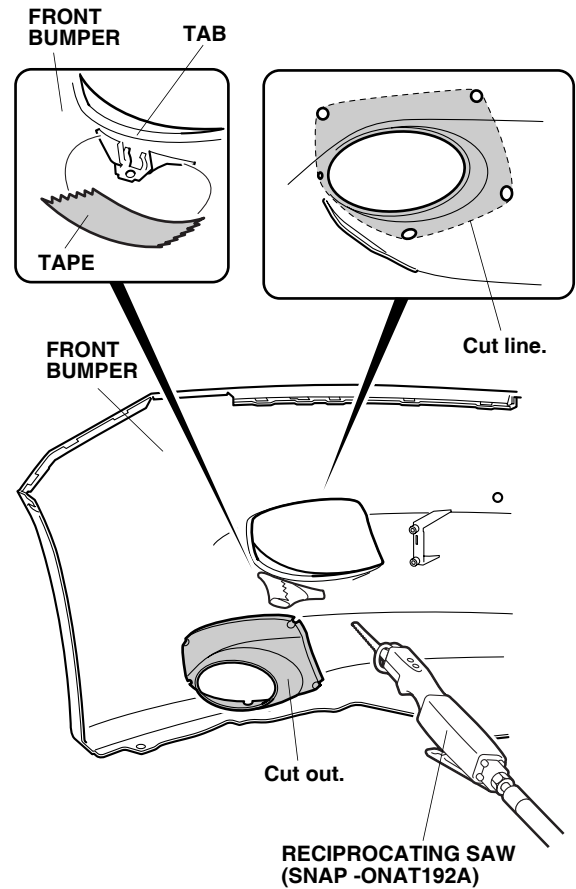

14. Inside the front bumper, locate the two scribe marks in the area shown, and punch the cross sections of the two scribe marks with a push pin.
15. While wearing eye protection, drill a 3 mm hole through the mark from the front bumper as shown. Finish with a 10 mm bit. Remove all burrs.
16. Drill a 3 mm hole through the mark from the front bumper as shown. Finish with a 12 mm bit. Remove all burrs.
17. Repeat the steps 14 through 16 on the right side.

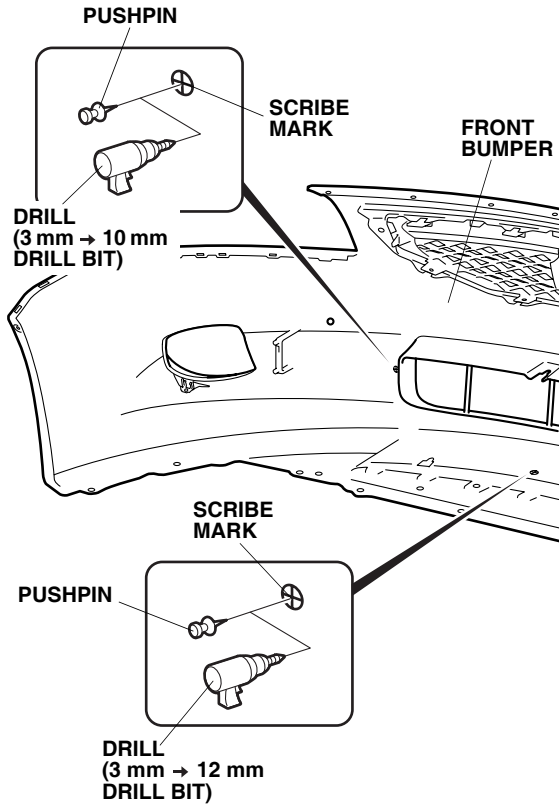

18. Align the template A with the front bumper as shown. Using a push pin, mark the front bumper as shown. Remove the template A.

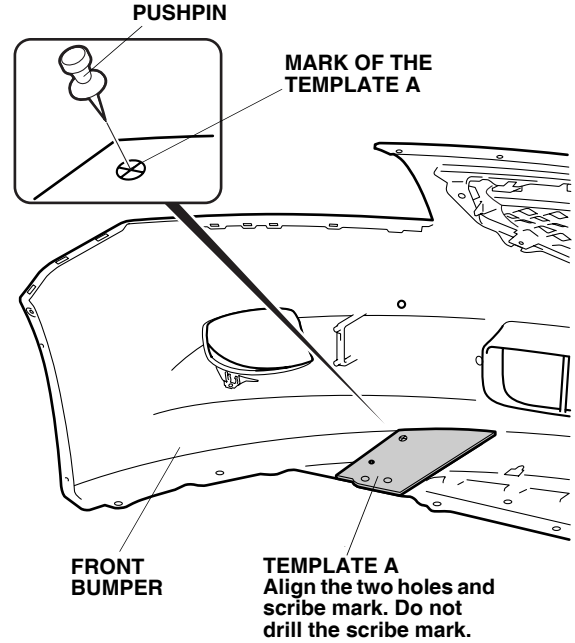

19. Drill a 3 mm hole through the mark from the front bumper as shown. Finish with a 12 mm bit. Remove all burrs.
20. Reverse the template A and repeat the steps 18 and 19 on the right side.

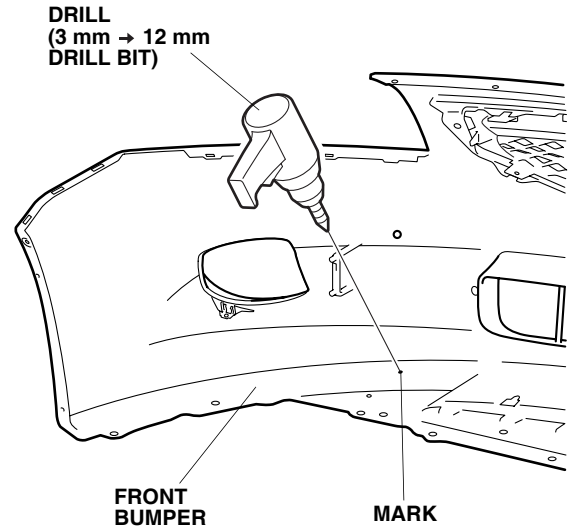

21. While wearing eye protection, drill a 3 mm hole through the center of the two dimpled areas on the front bumper as shown. Remove all burrs.
22. Slide the two spring nuts over the two holes drilled in the front bumper.
23. Repeat the steps 21 and 22 on the right side.

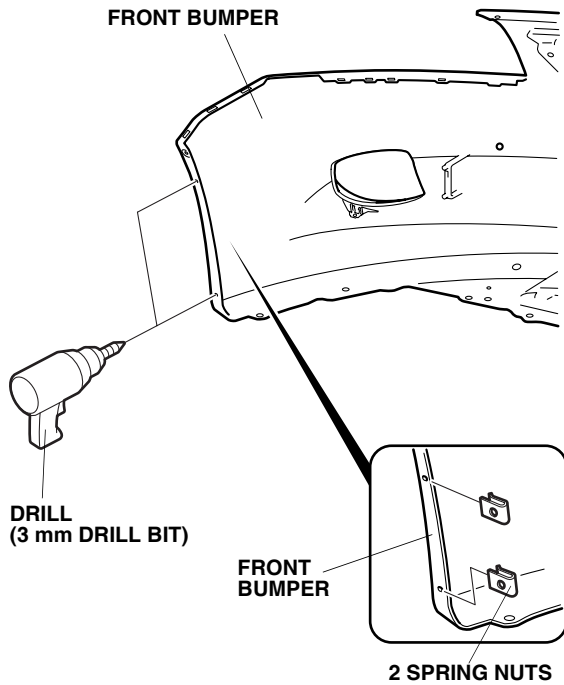

24. Attach a strip of masking tape to the end of each adhesive backing, and peel back 30 to 40 mm of the adhesive backings. Fold the ends back, and tape them to the front of the front under spoiler.

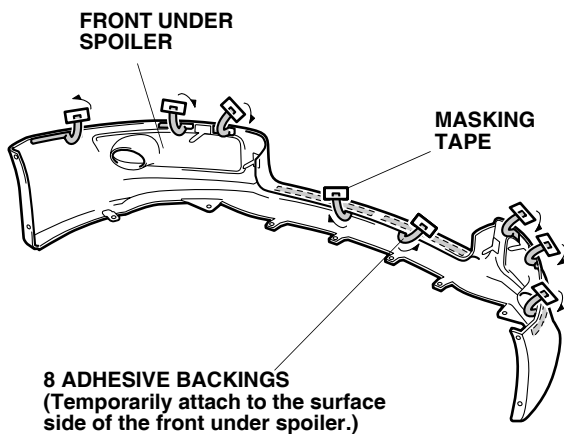

25. Using isopropyl alcohol on a shop towel, clean the front bumper where the front under spoiler will attach.
26. Position the front under spoiler on the front bumper and through the four clips to the hole, then install it with six bumper bolts and six flange nut as shown.

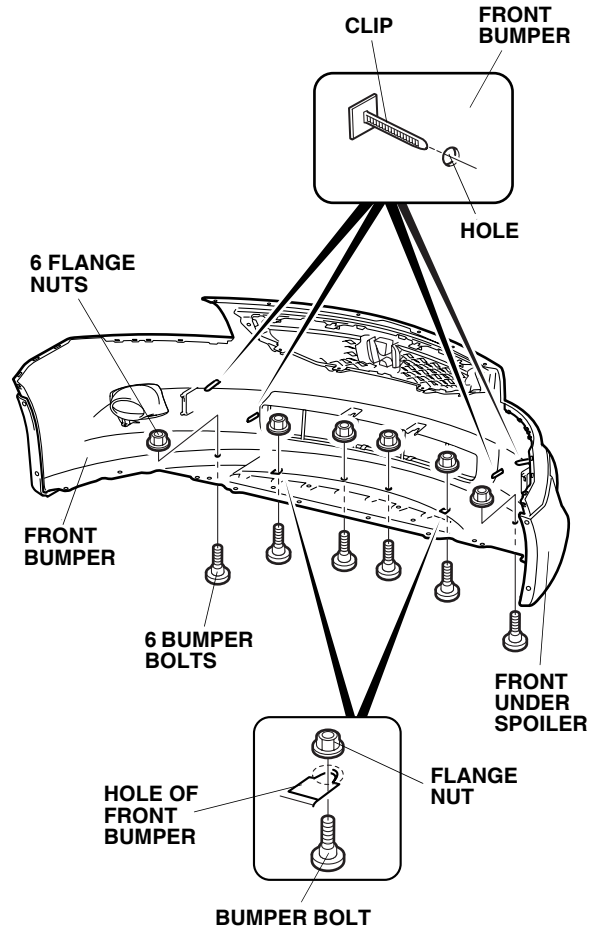

27. Install one EPDM sponge on each clip on the front under spoiler as shown.
28. Remove the adhesive backing from each EPDM sponge and install clip retainer on each clip as shown.

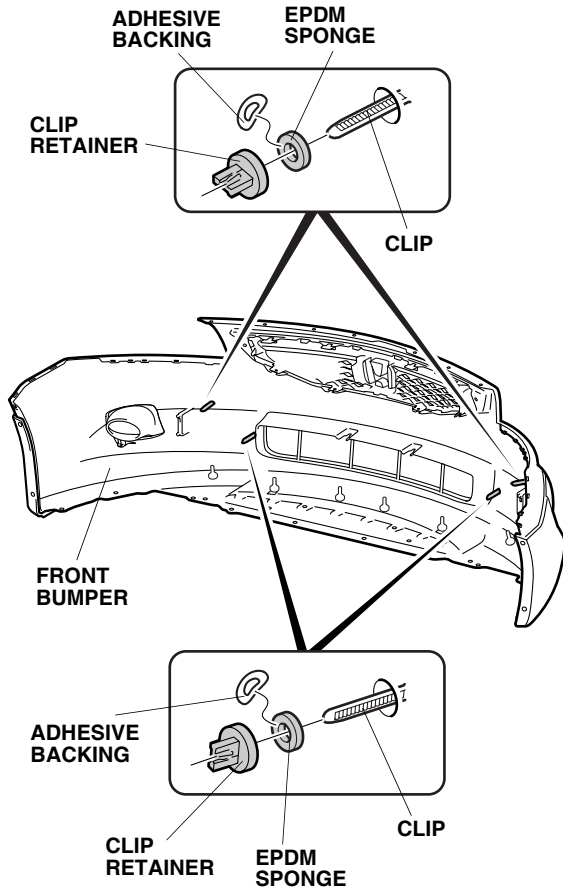

29. Reinstall the left fog light cover or left fog light, using the three self-tapping screws (reuse) to the front bumper.
30. Repeat the step 29 on the right side.

**Equipped with fog light cover**

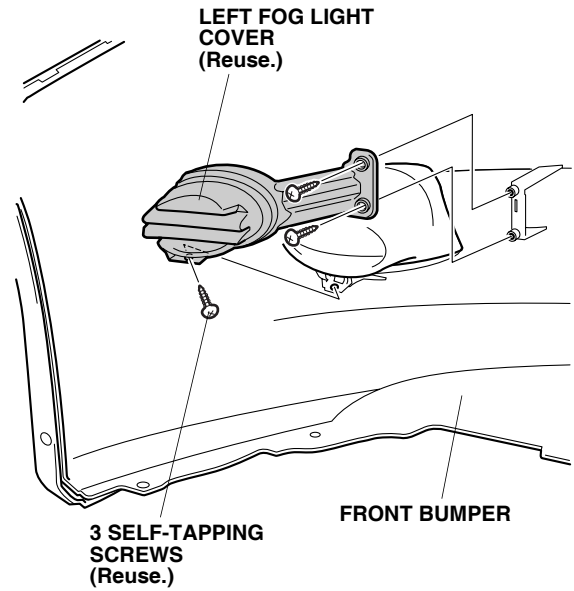

**Equipped with fog light**

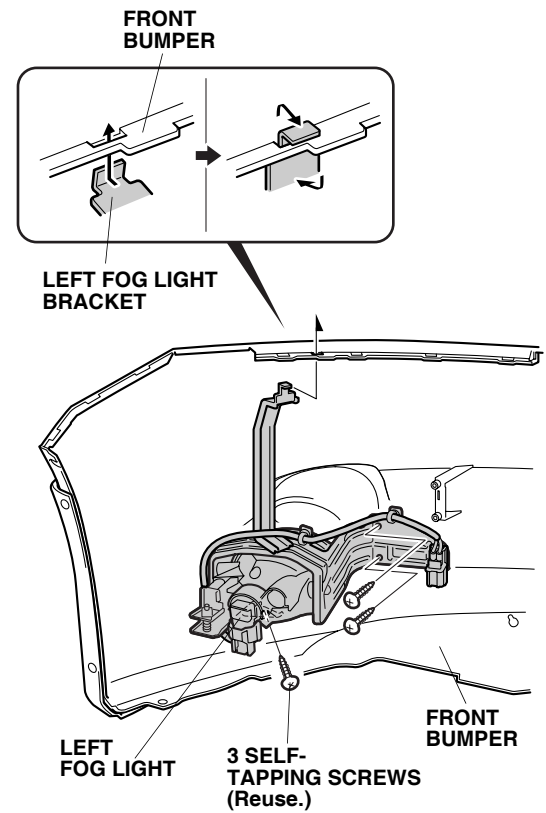

31. Using two self-tapping screws (reuse), eight clips (reuse), four 5 x 18 mm self-tapping screws and two clips, install the front bumper. Reconnect the fog light harness connectors.

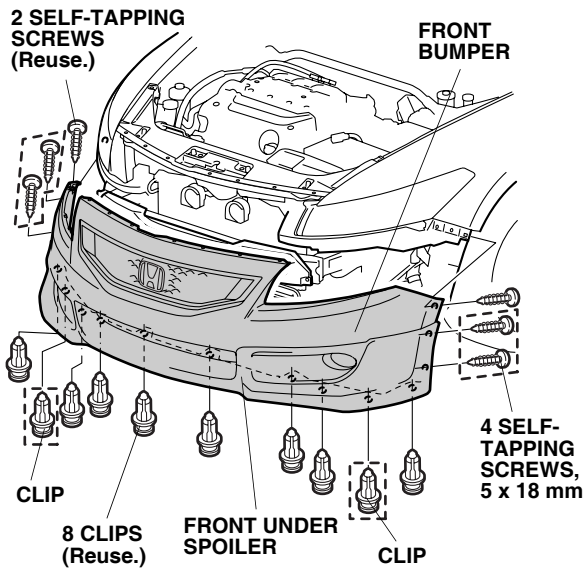

32. While applying pressure on the front under spoiler, carefully remove the adhesive backings in the from the center outwards. After removing, the backings hold the front under spoiler firmly against the front bumper with the palm of your hand for 30 seconds.

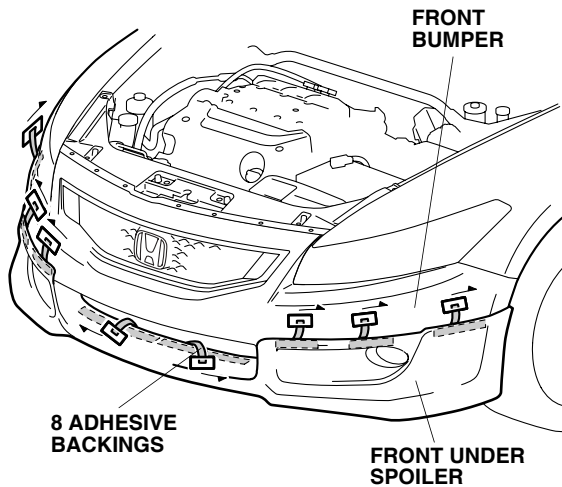

33. Using ahead rubber roller, apply firm pressure while rolling to set the adhesive.  
34. Reinstall all removed parts.

