



# INSTALLATION INSTRUCTIONS

Accessory

**FOG LIGHTS**  
(GX, LX, LX SE, EX, EX SE, VP)

Application

**2005 CIVIC**  
**2- AND 4- DOOR**

Publications No.

**All 27866-30848**

Issue Date

**SEP 2005**

**NOTE: Fog Lights cannot be installed if the vehicle is equipped with an optional Front Under Spoiler or a Cigarette Lighter with Ashtray.**

## PARTS LIST

**Fog Lights (sold separately):**  
**P/N 08V31-S5D-102A**

Left fog light

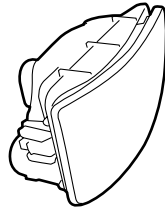

Right fog light

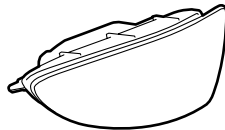

Switch harness

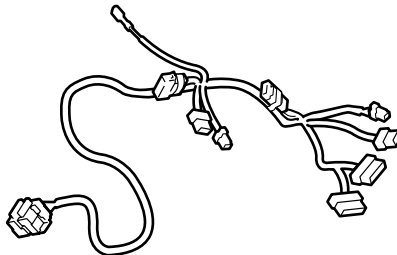

Fog light harness

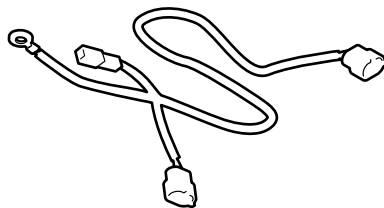

Relay

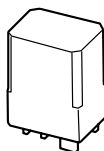

Fuse label

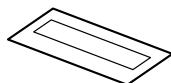

33 Wire ties

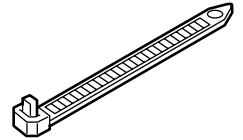

7 Wire ties with clip

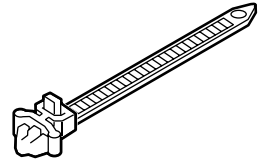

Cushion tape

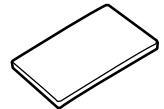

3 Washer-bolts



Relay bracket

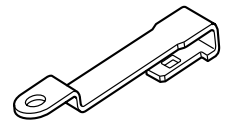

Subharness

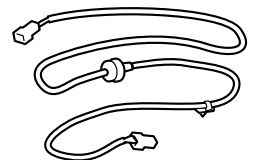

**Switch Kit (sold separately):**  
**P/N 08V31-S5D-120C (4-door)**  
**P/N 08V31-S5P-120C (2-door)**

Switch

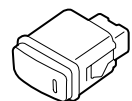

## TOOLS AND SUPPLIES REQUIRED

#2 Phillips screwdriver  
Flat-tip screwdriver  
Ratchet  
10 mm Sockets  
Drill  
3 mm, 6 mm, and 8 mm Drill bits  
Diagonal cutters  
File  
Eye protection (safety goggle, face shield, etc.)  
Gloves  
Masking tape  
Hand saw  
Blanket  
Pushpin

### *Illustration of the Fog Lights Installed on the Vehicle*

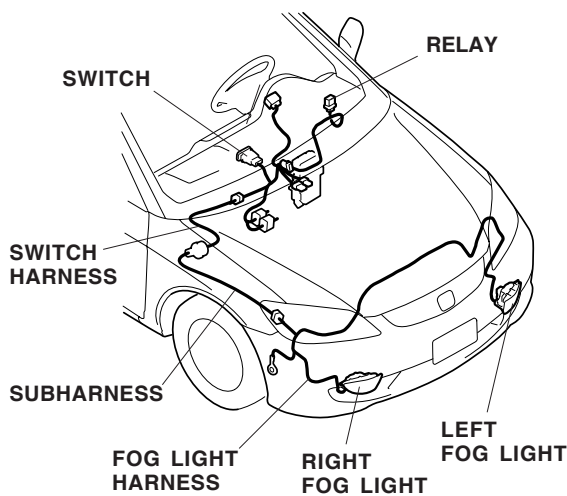

## INSTALLATION

**Customer Information:** The information in this installation instruction is intended for use only by skilled technicians who have the proper tools, equipment, and training to correctly and safely add equipment to your vehicle. These procedures should not be attempted by “do-it-yourselfers.”

1. Make sure you have the anti-theft code for the radio, then write down the radio station presets.
2. Open the hood and disconnect the negative cable from the battery.

### Cutting the Front Bumper

3. Remove these parts from the front bumper (four top clips, six bottom clips, two bottom self-tapping screws, and two fender area screws). Remove the front bumper by pulling it out toward you. Place the front bumper on a blanket, to prevent damage while installing the fog lights.

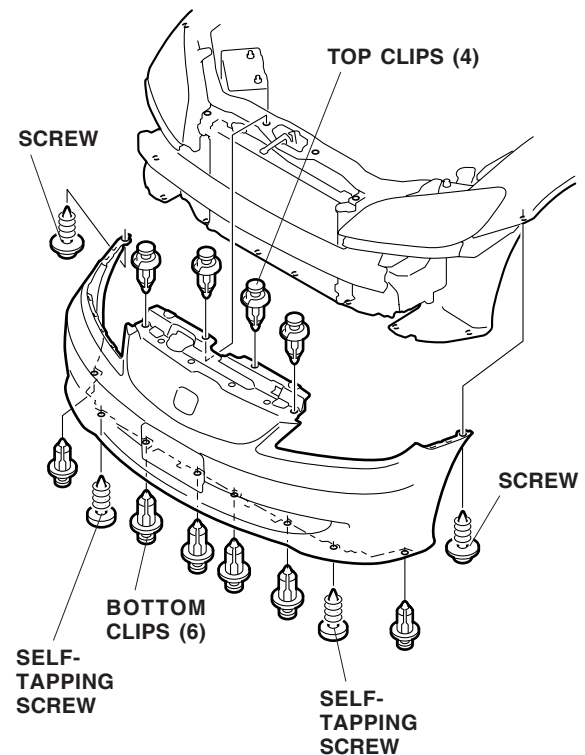

4. Apply masking tape around the cover on the left side of the front bumper as shown.

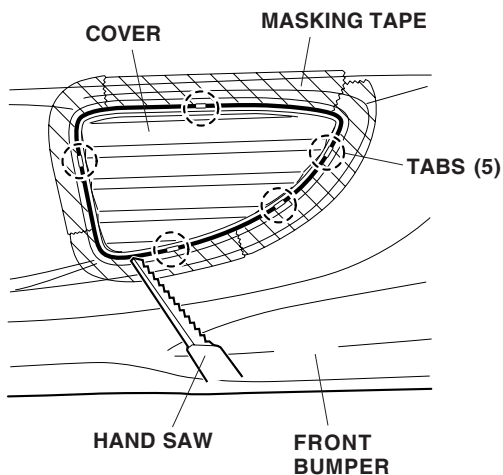

5. Wearing gloves, remove the cover from the left side of the front bumper by cutting the five tabs with a hand saw.
6. Using a file, finish the edges smooth and flat, and remove the masking tape.
7. Inside the bumper, make a hole in the center mark on the bumper with a pushpin.

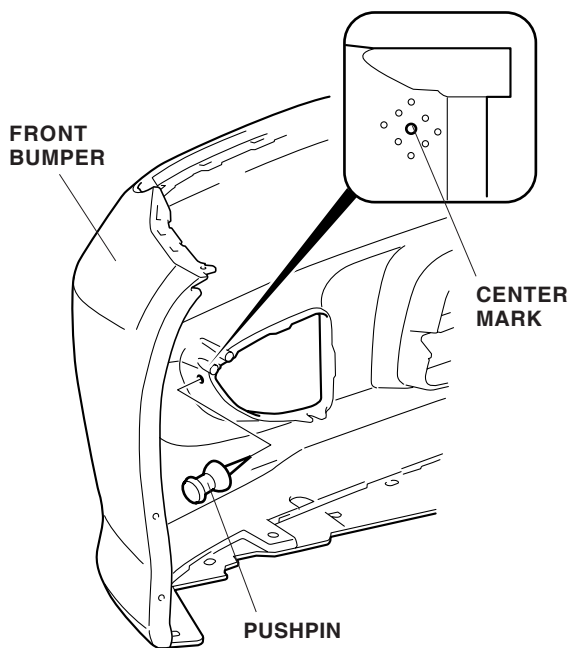

8. While wearing eye protection, drill an 8 mm hole through the hole you just made. First drill with a 3 mm drill bit, then with a 6 mm drill bit, and finish with an 8 mm drill bit. Remove any burrs from the edge of the hole.

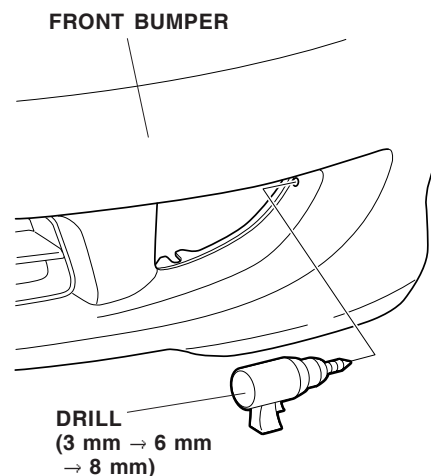

9. Repeat steps 4 thru 8 to cut and drill the right side of the bumper.

### Routing the Fog Light Harness

10. Disconnect the positive (+) battery cable. Remove the battery positive cable and clip from the battery.

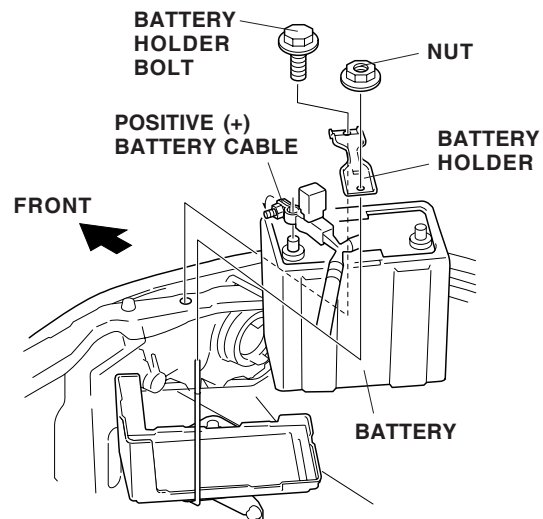

11. Remove the battery holder bolt and nut, then remove the battery holder.
12. Remove the battery.

- Remove the power steering reserve tank from the vehicle bracket by pulling it upward. Move the reserve tank out of the way.

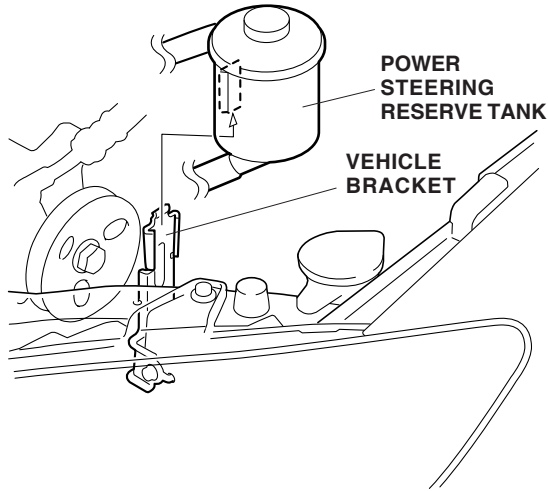

- Route the fog light harness 2-pin connector (long side) through the rectangular hole under the rear of the right headlight up into the engine compartment.

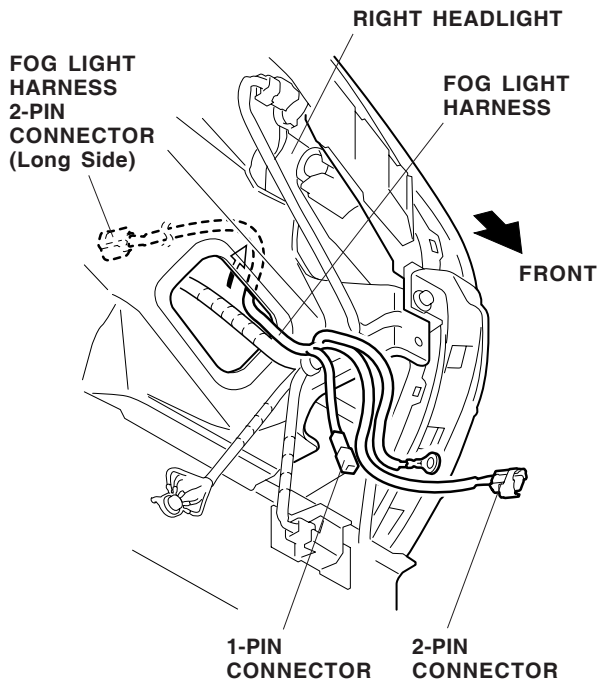

- On the vehicle frame, remove the ground terminal bolt, then attach the fog light harness ground terminal using the ground terminal bolt.

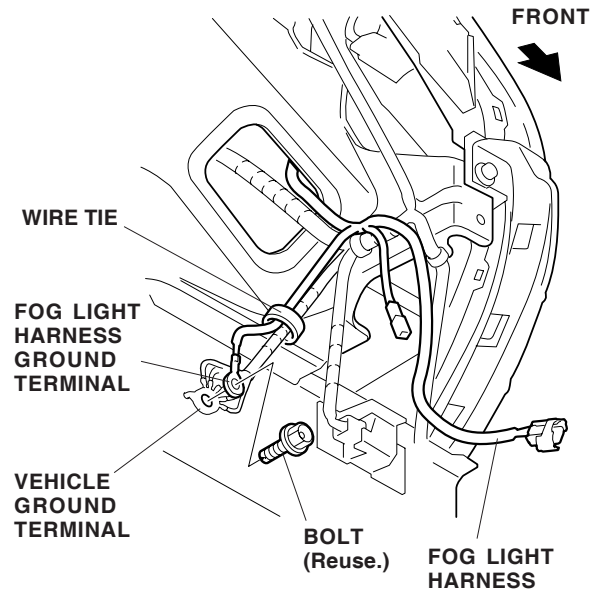

- Secure the fog light harness to the vehicle harness with wire tie, near the rectangular hole, in the front fender.

- Route the fog light harness to the left (driver's) side along the vehicle harness. Secure it to the vehicle harness with the four wire ties in the areas shown.

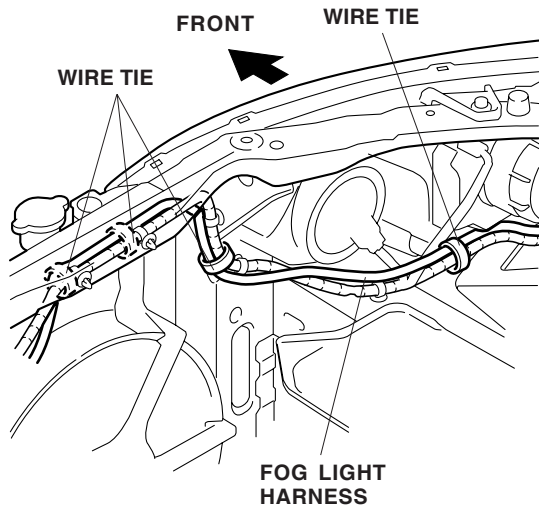

- Continue to route the fog light harness to the left (driver's) side along the vehicle harness and up through the opening under the left headlight.

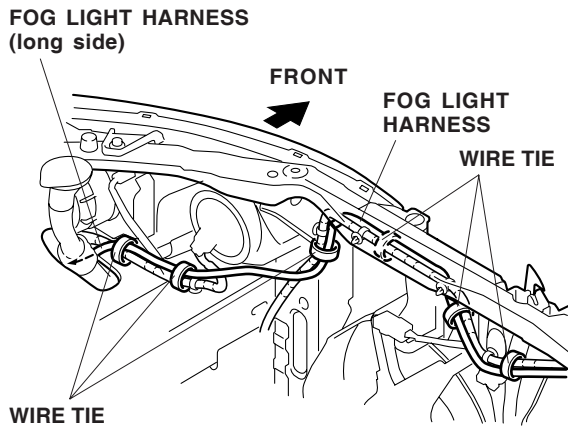

- Secure the fog light harness to the vehicle harness with six wire ties.

- On the right (passenger's) side of the vehicle, secure the fog light harness to the vehicle harness with one wire tie.

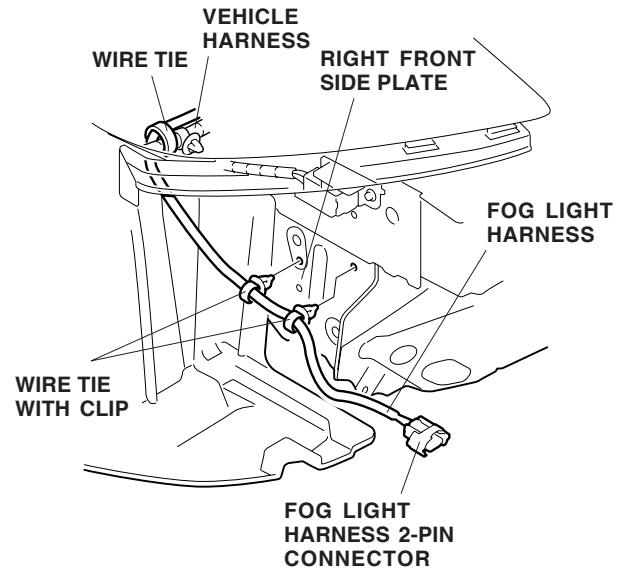

- Attach two wire ties with clips to the fog light harness, then push the clips into the holes in the right front side plate.
- Secure the fog light harness, routed to the lower side of the left headlight, to the vehicle harness with three wire ties in the areas shown. Do not secure to the fog light harness to the yellow SRS harness.

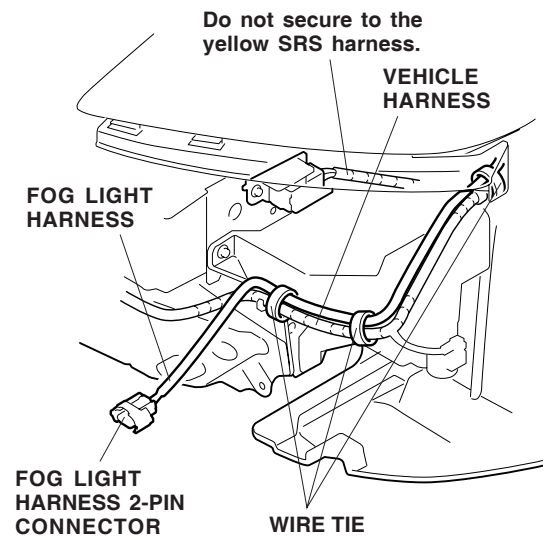

## Installing the Fog Light

23. Push the boss of the left fog light into the hole in the front bumper made in step 8, then fit the left fog light into place on the left of the front bumper.

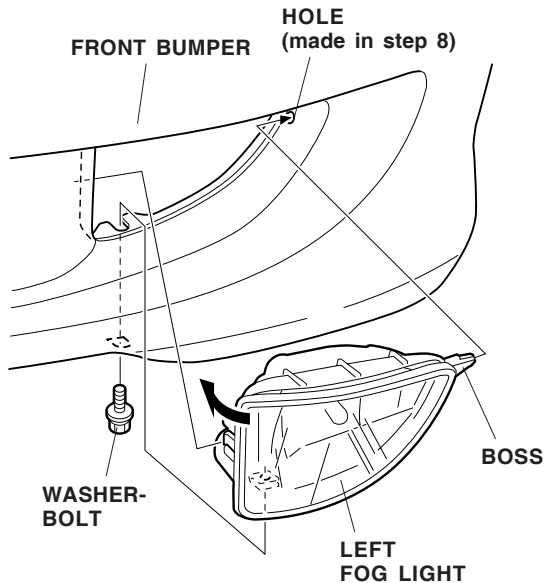

24. Under the front bumper, install the washer-bolt to secure the left fog light to the front bumper.
25. Repeat steps 23 and 24 to install the right fog light onto the bumper.

## Routing the Subharness

26. Remove the six clips and two self-tapping screws, and pull the right (passenger's) side front inner fender down in the direction shown.

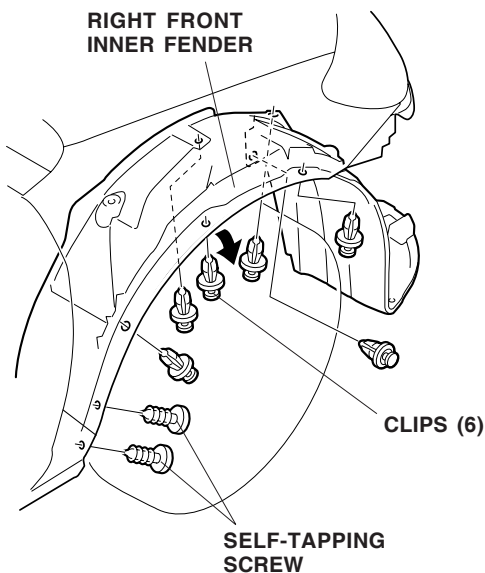

27. Inside the right front inner panel, locate the rubber grommet. Push the grommet out and into the passenger's compartment. Route the subharness into the passenger's compartment, and seat the harness grommet in the panel hole.

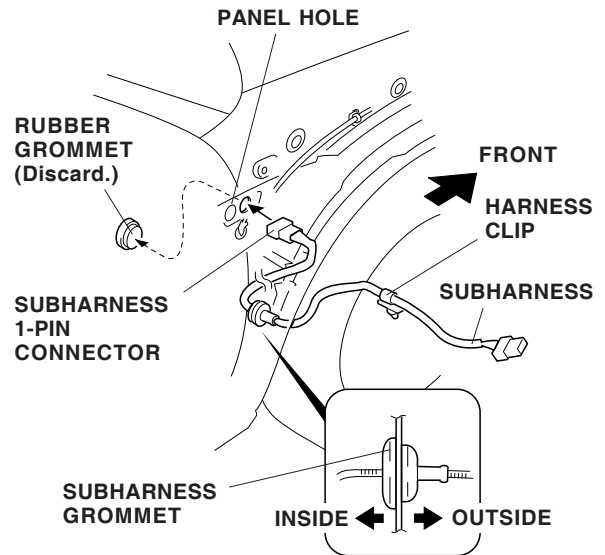

28. Route other end of the subharness through the inner fender toward the front of the vehicle. Plug the subharness 1-pin connector into the fog light harness 1-pin connector routed in step 14.

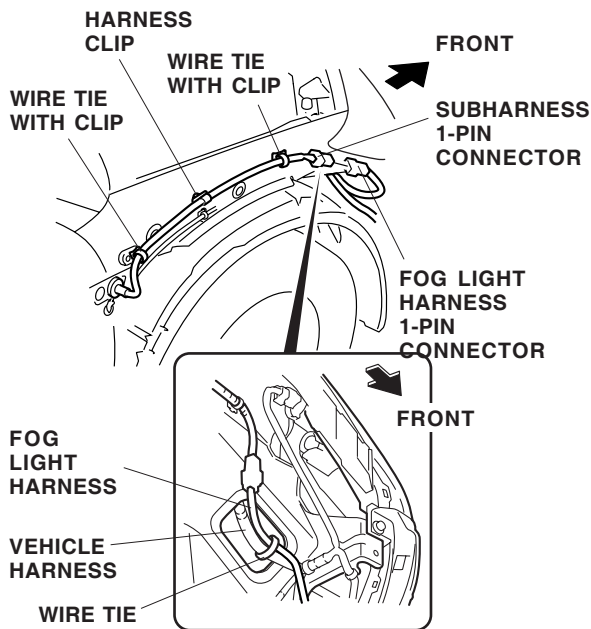

29. Near the 1-pin connector, secure the fog light harness to the vehicle harness with one wire tie in the area shown. Attach the subharness to the inner fender panel with two additional wire ties with clips from the kit, and the one harness clip already attached to the subharness. Insert the clips into the empty holes in the inner fender panel.
30. Reinstall the right (passenger's) side front inner fender.

31. With the help of an assistant, connect the fog light harness 2-pin connectors to the right and left fog lights, and reinstall the front bumper.

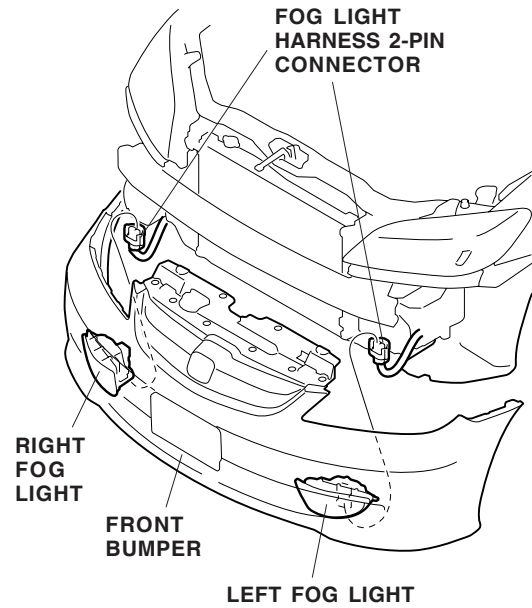

#### Routing the Switch Harness

32. Inside the passenger's compartment, remove the dashboard lower cover on the driver's side. Turn the two knobs counterclockwise, and release the four retaining tabs.

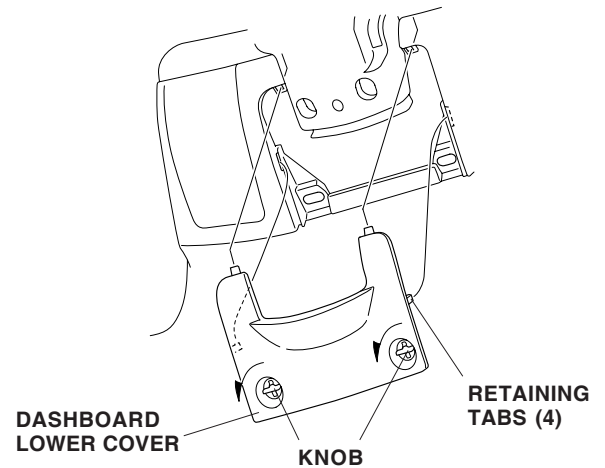

33. Turn the knob counterclockwise, and release the two clips, and remove the driver's dashboard under cover.

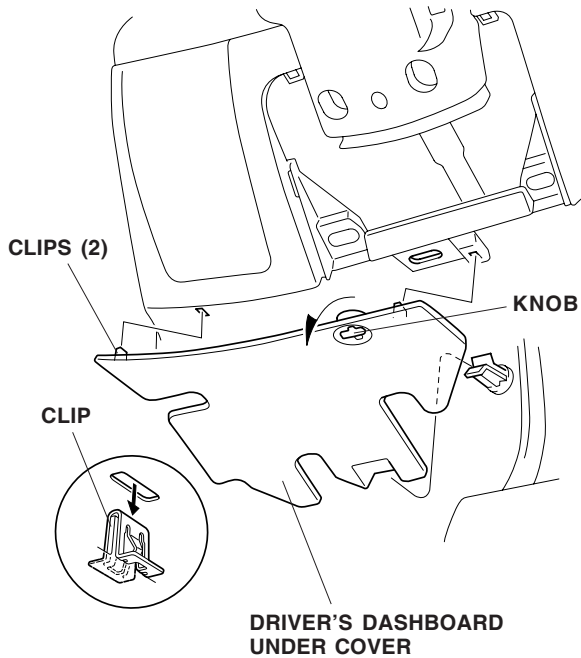

34. Remove the upper and lower column covers (three washer-screws, six retaining tabs).

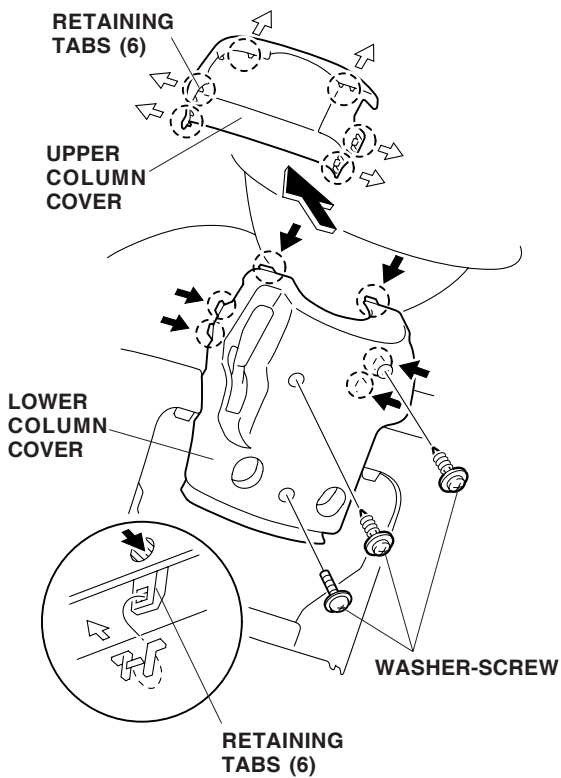

35. Remove the driver's pocket (one self-tapping screw and two retaining tabs). If equipped with a switch, open the pocket, remove the self-tapping screw to release the panel, and disconnect the harness from the switch.

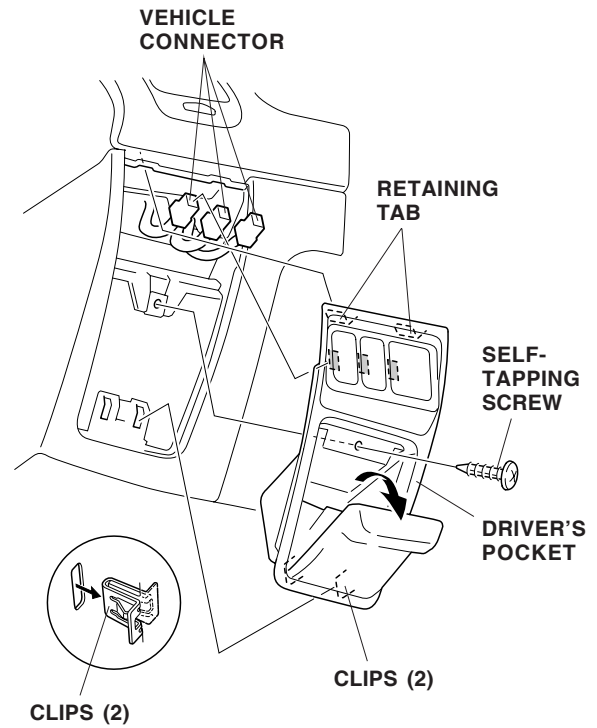

36. Remove the right (passenger's) side kick panel (two clips).

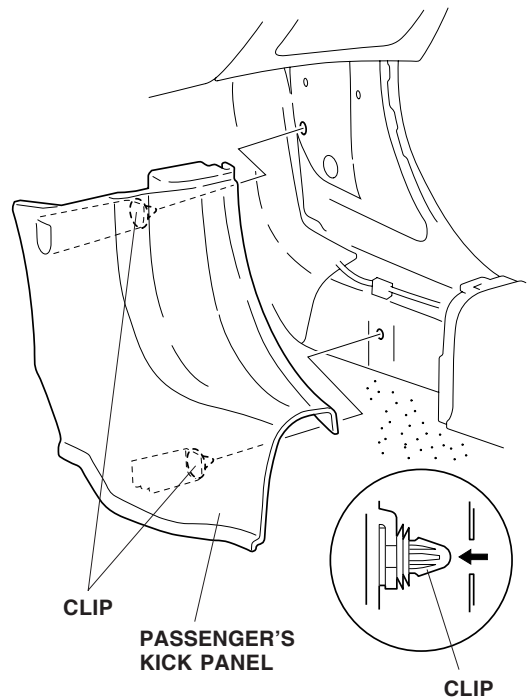

37. Remove the escutcheon, and center console trim.

**A/T Model:**

- With the parking brake applied, place the gear shift lever in the Neutral Position.
- Pry up on the four retaining pawls and remove the escutcheon tabs.
- Pry up on the three clips and six retaining tabs and remove the center console trim.

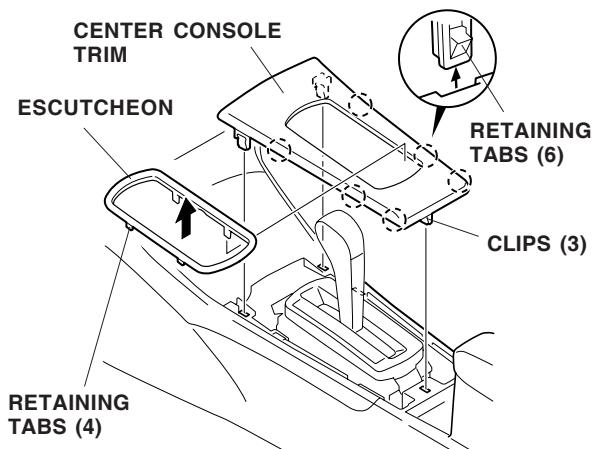

**M/T Model:**

- Remove the shift knob from the lever by holding the plastic section above the boot down firmly with one hand, and turning the knob in a counterclockwise direction with the other hand.
- Pry up on the four retaining tabs and remove the escutcheon.
- Pry up on the three clips and six retaining tabs and remove the center console trim.

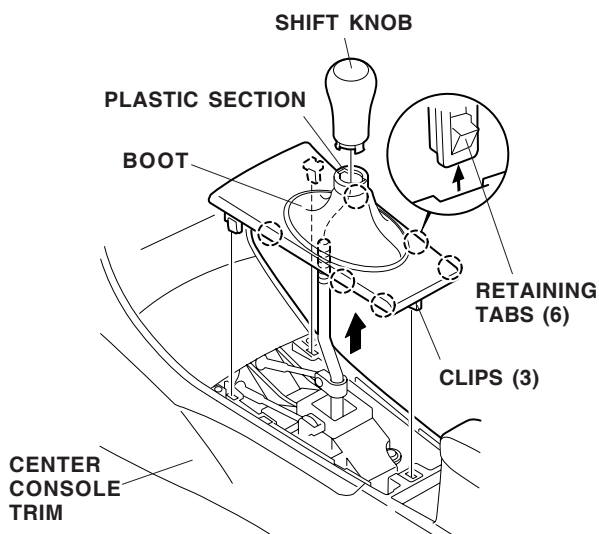

38. Remove the center lower trim (two self-tapping screws, nine clips, one retaining tab, and unplug the accessory socket connector).

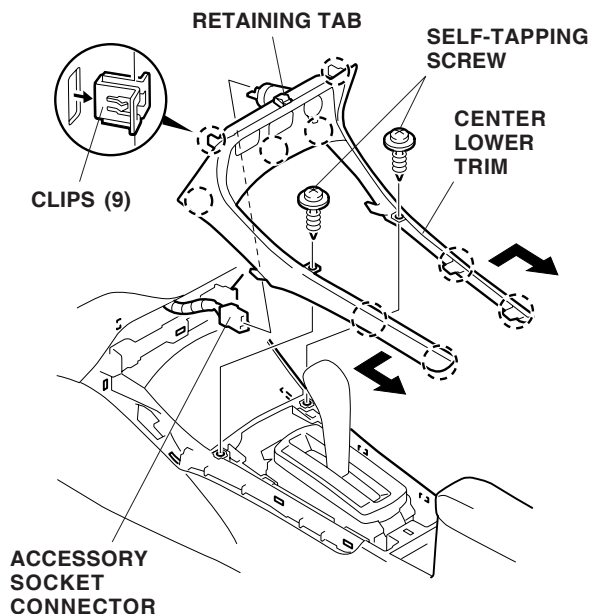

39. Open the center console lid, and remove the mat.

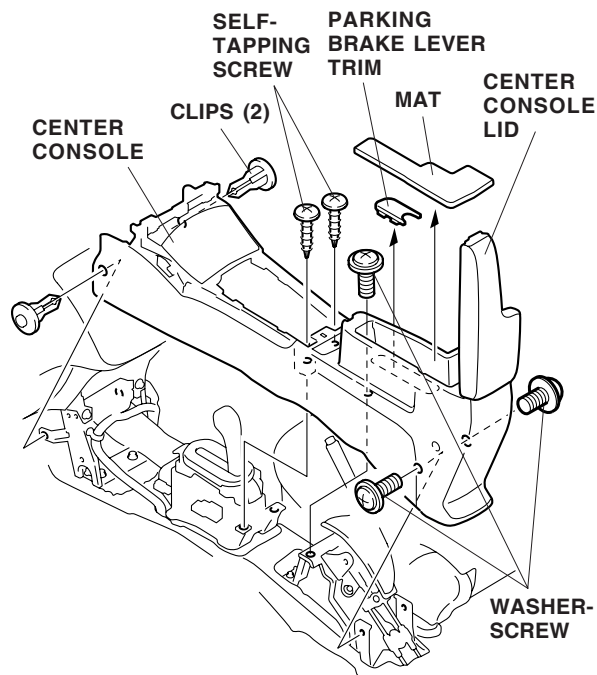

40. Remove the parking brake lever trim, and remove the center console (two self-tapping screws, three washer-screws and two clips).

41. Lower the passenger's side under cover, release the three clips and remove the under cover.

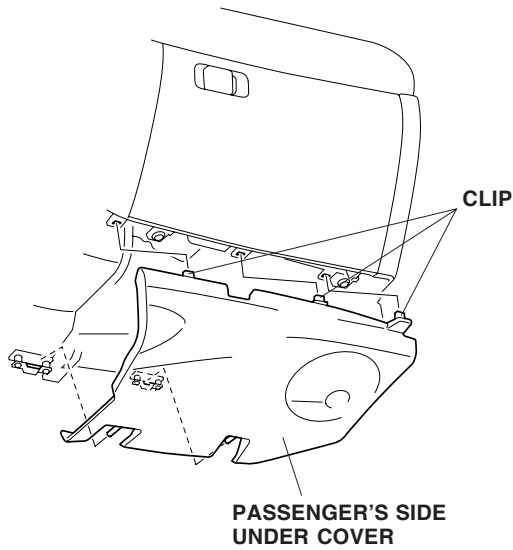

42. Open the glove box completely, and remove the stopper from each side.

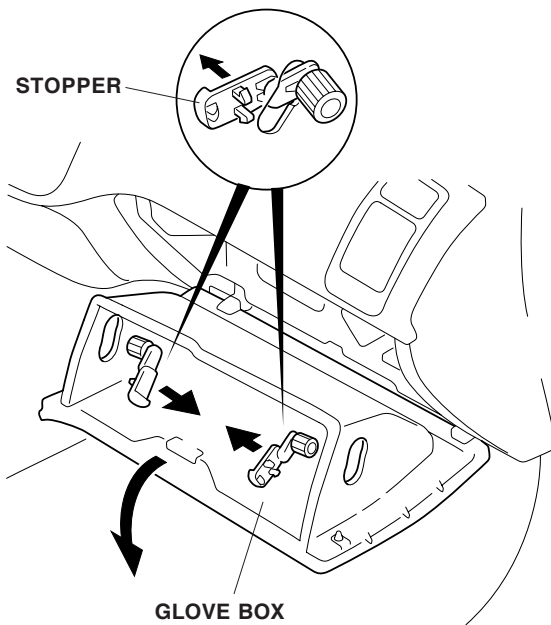

43. Locate the subharness installed in step 27. Route the subharness through the glove box compartment area, and secure the subharness to the vehicle harness with four wire ties.

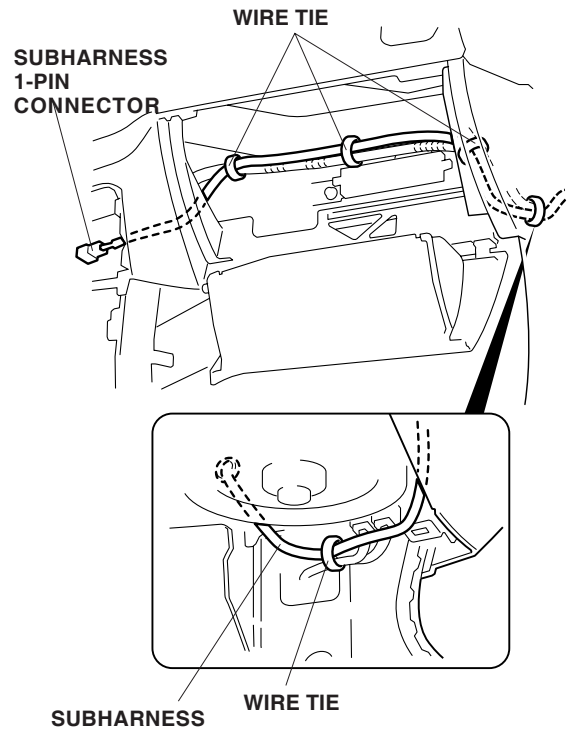

44. Get the switch harness. Route the switch harness under the dash, and over the steering shaft and the brake position switch harness.

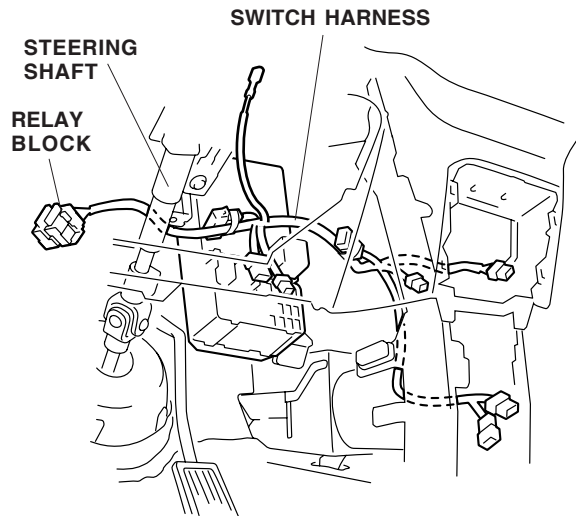

45. Attach the relay bracket to the steering hanger beam using the washer-bolt.

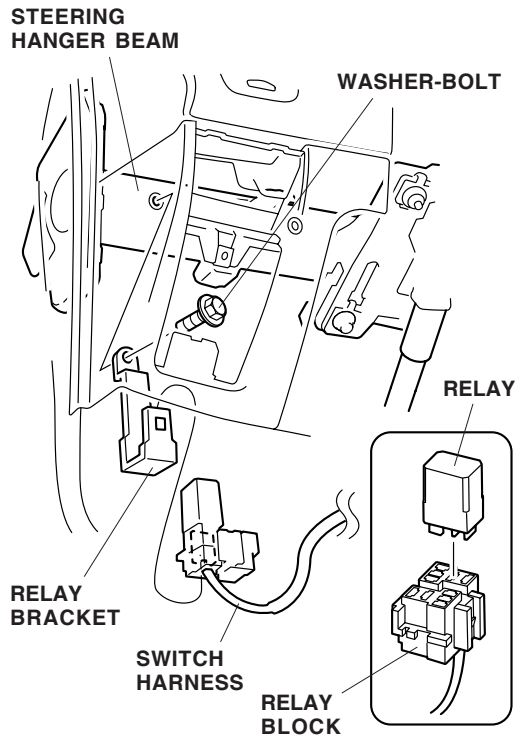

46. Plug the relay into the relay block, then attach the relay block to the relay bracket.

47. Plug in the 6-pin connector:

**A/T Model:** Remove the tape to free the switch harness 6-pin connector. Unplug the vehicle 6-pin connector (green) from the fuse box, and plug the green 6-pin connector from the switch harness into the fuse box. Plug the vehicle 6-pin connector (green) into the remaining switch harness 6-pin connector (green).

**M/T Model:** There is no 6-pin connector plugged into the fuse box; plug the switch harness 6-pin connector directly into the fuse box.

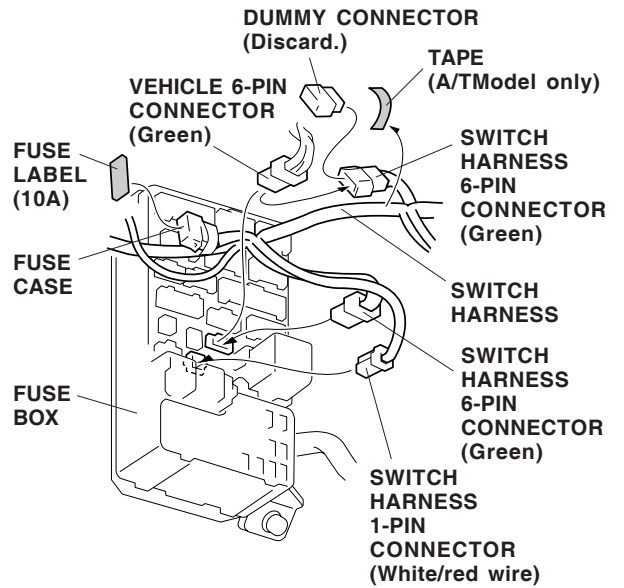

48. Plug the switch harness 1-pin connector (white/red wire) into the fuse box in the location shown.
49. Attach the 10A fuse label to the fuse case on the switch harness.

50. Locate the 4-pin and 10-pin connectors near the center console frame, and unplug the connectors. Unclip the 10-pin connector from the 4-pin connector. Plug the switch harness 10 pin connectors in between the vehicle harness 10-pin connectors. Plug in the 4-pin connector, and reattach it to the switch harness 10-pin connector.

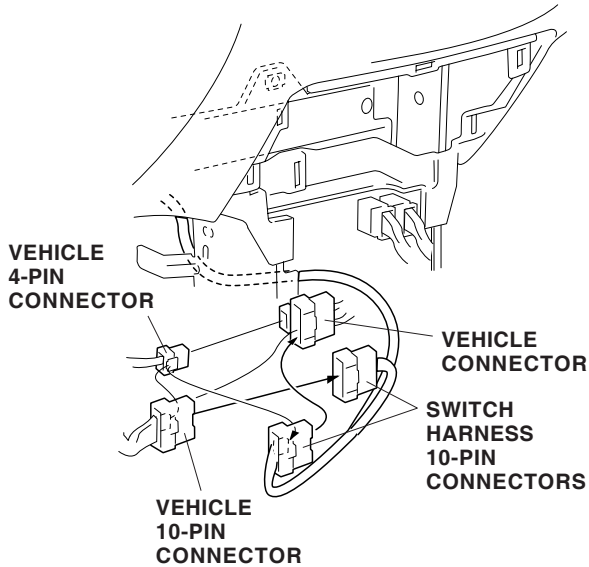

51. Secure the switch harness to the vehicle harness with two wire ties in the areas shown.

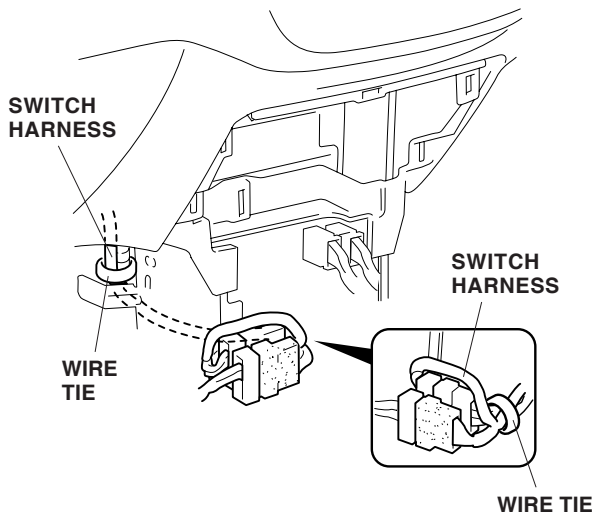

52. Plug the subharness 1-pin connector (routed in step 43) into the switch harness 1-pin connector (blue/red), then wrap one cushion tape around the connectors. Secure the connector to the vehicle harness using one wire tie.

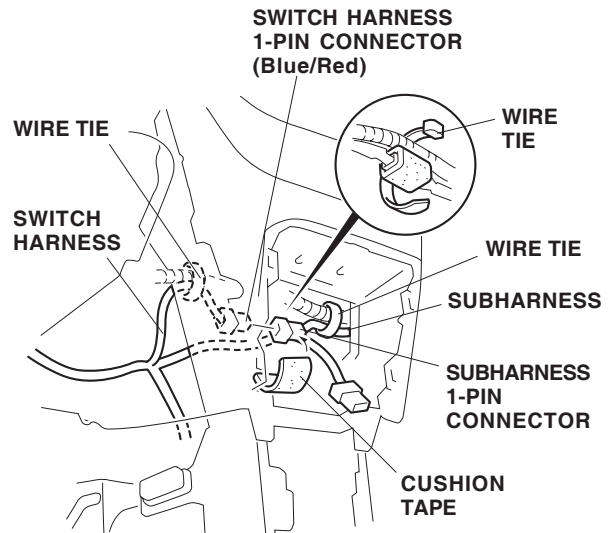

53. Secure the subharness and switch harness to the vehicle harness with two wire ties in the areas shown.
54. Remove and discard the switch cover from the center lower trim (removed in step 38), then pull the switch harness 6-pin connector out through the hole in the lower trim.

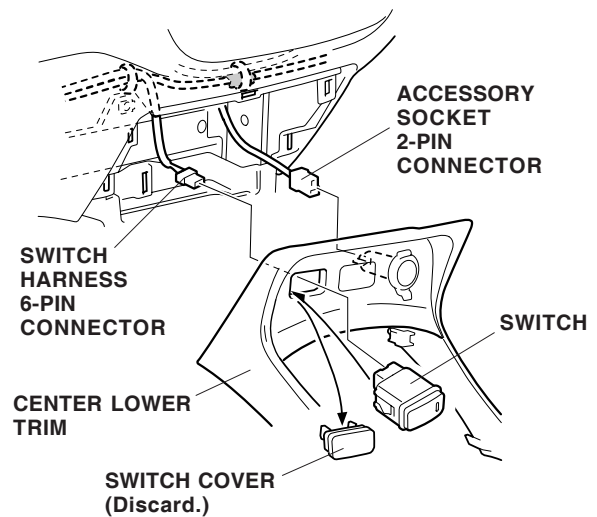

55. Plug the switch harness 6-pin connector into the fog light switch, then install the fog light switch into the center lower trim.
56. Reinstall the center lower trim.

57. Route the switch harness terminal (long end) above the combination switch along the vehicle harness.

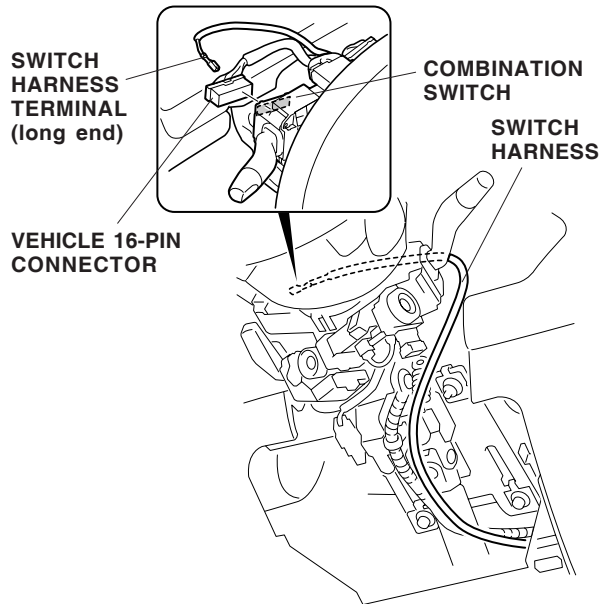

58. On the left side of the combination switch, unplug the vehicle 16-pin connector.
59. Release the retainer of the vehicle 16-pin connector, then push the one terminal of the switch harness into the appropriate slot of the vehicle 16-pin connector.

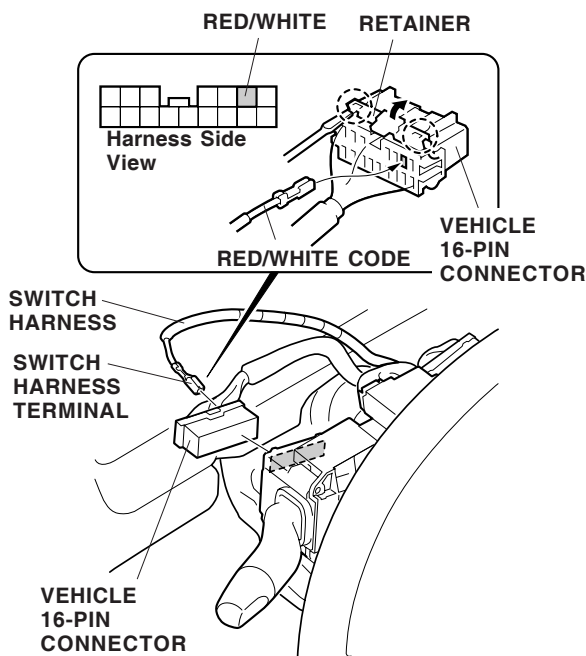

60. Reconnect the vehicle 16-pin connector.

61. Secure the switch harness to the vehicle harness with the two wire ties.

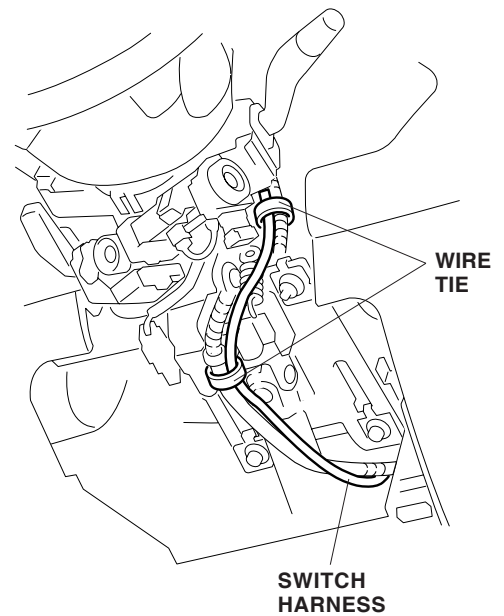

62. Under the dash, secure the switch harness to the vehicle harness with six wire ties in the areas shown.

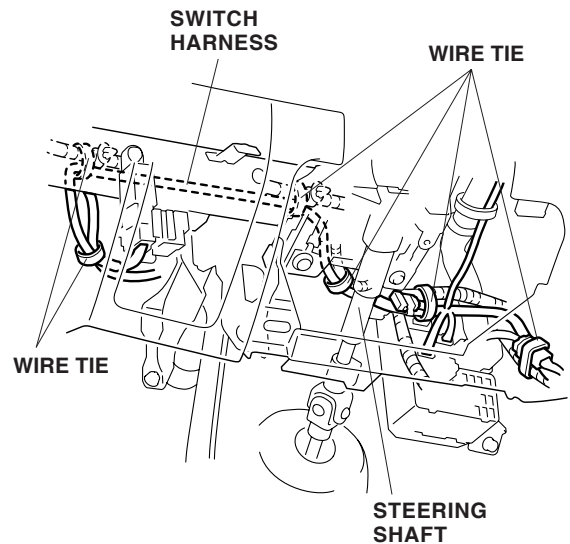

63. Check that all wire harnesses are routed properly and all connectors are plugged in.
64. Reinstall all removed parts.
65. Reconnect the negative cable to the battery.
66. Reset the clock and the radio station preset buttons.

NOTE: Whenever the battery is disconnected, the driver's window AUTO function is disabled.

67. Start the engine. Push down on the driver's window switch until the window is fully open.
68. Pull up on the driver's window switch to close the window completely, then hold the switch for 2 seconds or more.
69. Lower and raise the driver's window to check operation of the driver's window AUTO function.
70. Do the ECM/PCM idle learn procedure.
  - Make sure all electrical items are turned off.
  - Start the engine. Hold the engine speed at 3,000 rpm with no load (in Park or Neutral) until the radiator fan comes on.
  - Let the engine idle for about 5 minutes with the throttle fully closed and with all electrical items off.

NOTE: If the radiator fan comes on during this step, the time it operates must not be included in the 5 minutes.

## USE AND CARE

### How to Operate Fog Lights

- Turn the light switch to the "on" position (headlights on low beam).
- Press the fog light switch (indicator is on).

The fog light lenses can cloud when the outside temperature is cold; this is normal and should go away in warm weather.

## Fog Light Aiming Adjustment

### 1. Adjust the fog lights:

- Adjust the aim according to local laws and regulations.
- To adjust, turn the aiming adjustment gear in or out until the correct aiming is obtained.

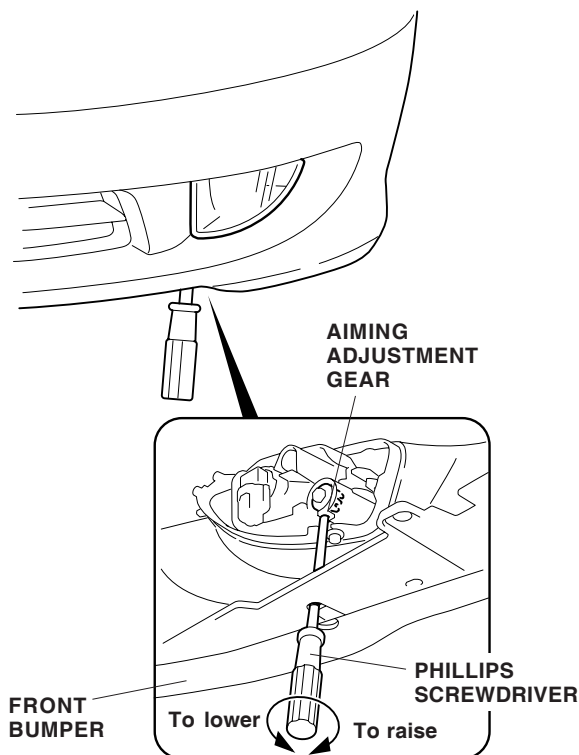

## BULB REPLACEMENT

1. Remove the washer-bolt that fastens the fog light, and pull the light out toward you.
2. Unplug the connector from the fog light, then remove the fog light.

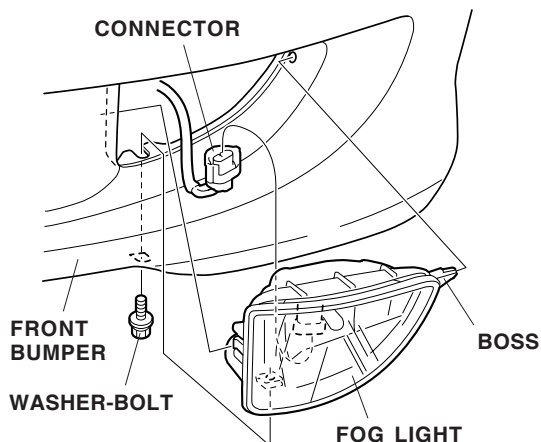

### 3. Remove the bulb along with the socket.

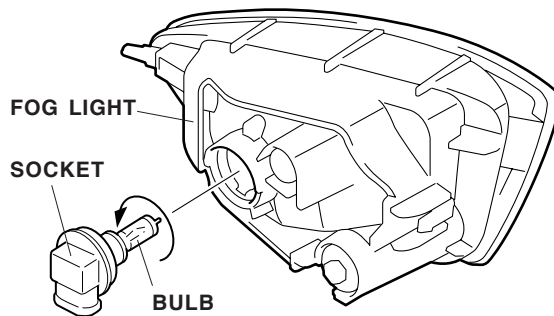

### 4. Install the new bulb and socket into the fog light.

- Use only a Honda halogen light bulb of the specified wattage.

Rating: 12V 35W H8 Halogen Light Bulb  
Bulb P/N: 33165-S5A-J010-M1

- Do not touch the bulb. Oily or greasy substances on the bulb can shorten its service life due to the heat produced when the bulb is turned on. If the bulb is accidentally touched, wipe it clean with a clean, soft cloth that has been dampened with denatured alcohol or mild detergent solution.
- Align the tab on the fog light with the cutout in the bulb socket when installing the new bulb. If not aligned, the fog light may not be aimed and annoy oncoming drivers.

### 5. Reinstall the fog light in the reverse order of removal.

- Check that the wire harnesses are not pinched.
- Be sure to tighten the self-tapping screws securely.

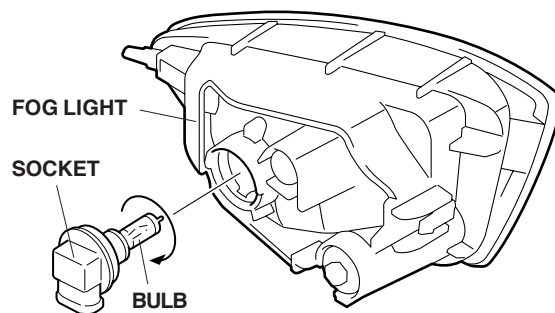

# CIRCUIT DIAGRAM

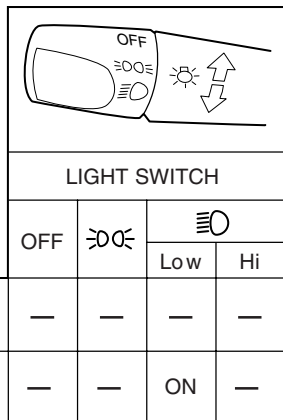
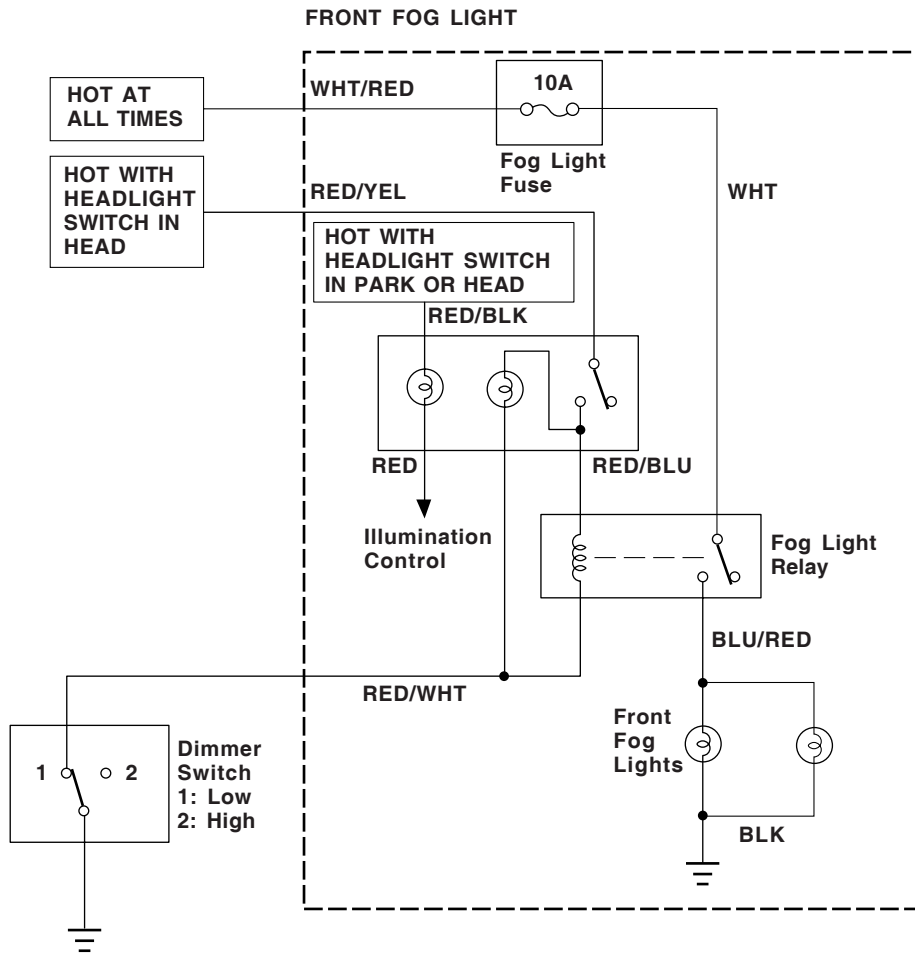

BLK	BLACK	LT BLU	LIGHT BLUE
YEL	YELLOW	BRN	BROWN
BLU	BLUE	ORN	ORANGE
GRN	GREEN	PNK	PINK
RED	RED	GRY	GRAY
WHT	WHITE	LT GRN	LIGHT GREEN