

**INSTALLATION
INSTRUCTIONS**

Accessory

**SPLASH GUARDS
P/N 08P00-S5D-100A**

Application

**2005 CIVIC
HYBRID**

Publications No.

All 28011

Issue Date

AUG 2004**PARTS LIST**

Left front splash guard

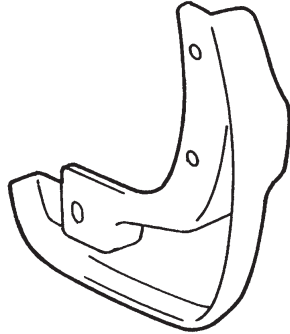

Right front splash guard

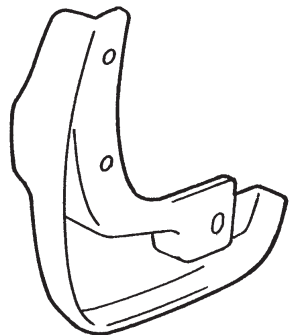

Left rear splash guard

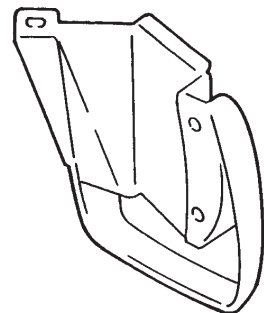

Right rear splash guard

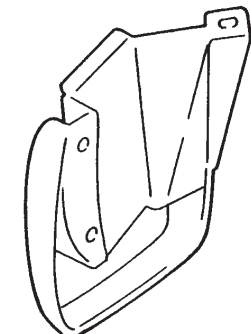

6 Self tapping screws

4 Spring nuts
(one not used)2 Grommets
(one not used)**TOOLS AND SUPPLIES REQUIRED**

Stubby Phillips screwdriver

Phillips screwdriver

Drill

3 mm and 8 mm drill bits

Pushpin

INSTALLATION

NOTE: These instructions show the left splash guards being installed. The same procedure applies to installing the right splash guards.

Installing the Front Splash Guards

1. Make sure the area to be covered is clean and has been waxed with a high-quality paste wax.

- Turn the steering wheel all the way counterclockwise.
- Remove and retain the three self-tapping screws fastening the left front inner fender to the front fender and fenderwell.

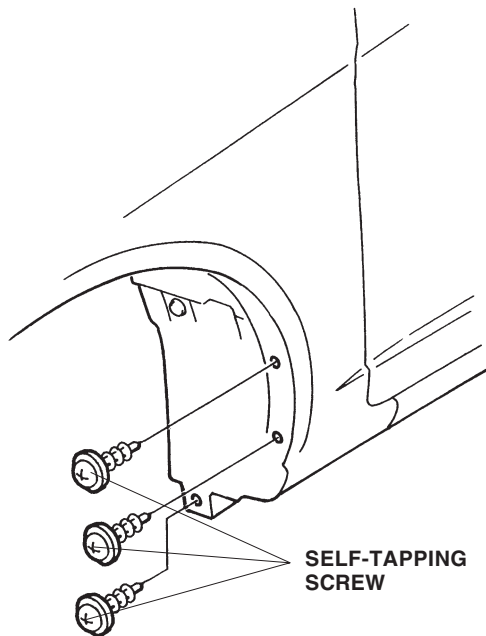

- Position the splash guard on the left front inner fender, and install three self-tapping screws you removed. Tighten the three self-tapping screws in the order of A, B, and C as shown.

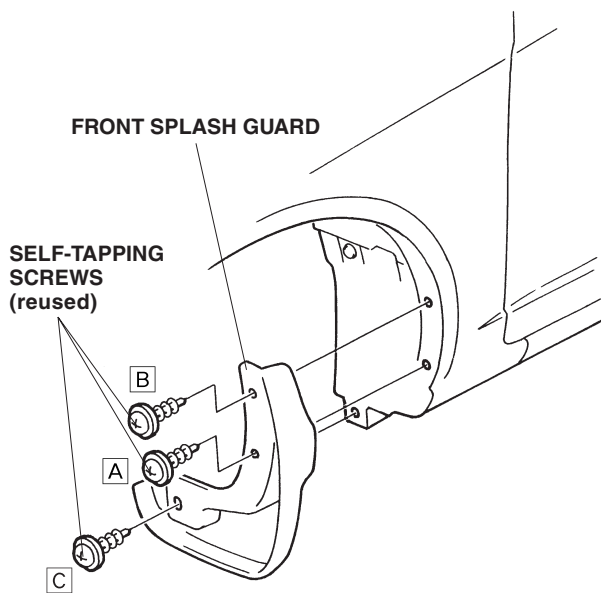

- Turn the steering wheel all the way clockwise and repeat steps 3 and 4 to install the right front splash guard.

Installing the Rear Splash Guards

Left side

- Remove the two self-tapping screws from the left inner fender.

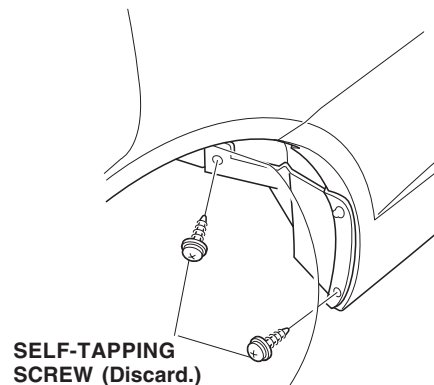

- Position the splash guard on the inner fender, and install the two self-tapping screws.
- Hold the splash guard firmly against the inner fender to eliminate clearance at the point shown. Mark the inner fender at the center of the screw hole with a pushpin.

Press to eliminate clearance between the splash guard and inner fender.

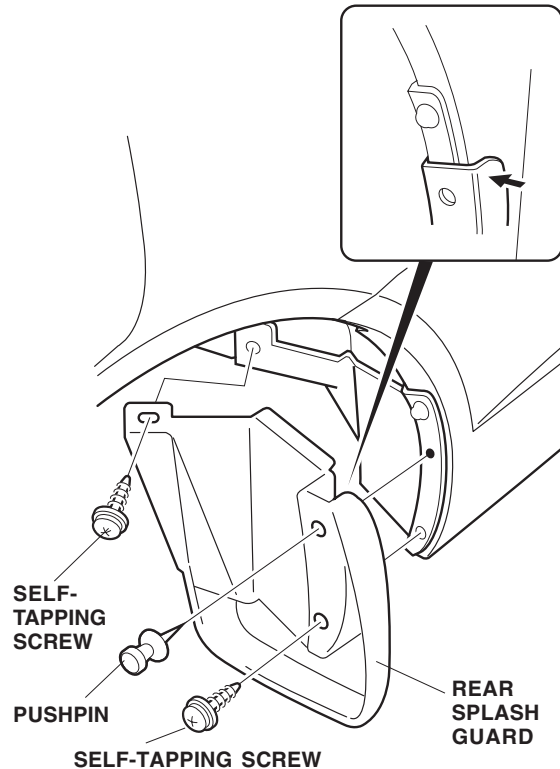

9. Remove the splash guard and inner fender (five self-tapping screws and three clips).

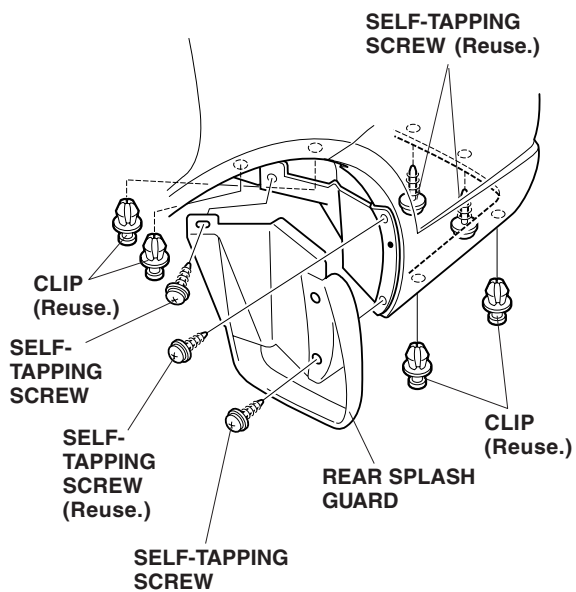

10. Drill an 8 mm hole through the mark you made on the inner fender. First drill with a 3 mm drill bit, then finish with an 8 mm drill bit.

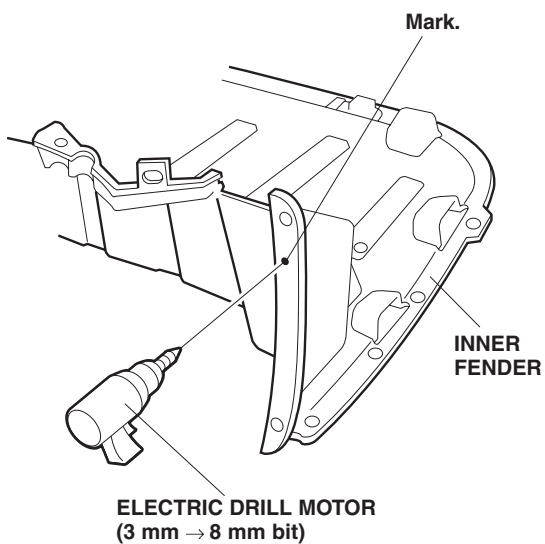

11. Slide a spring nut over the dimpled area of the rear bumper.

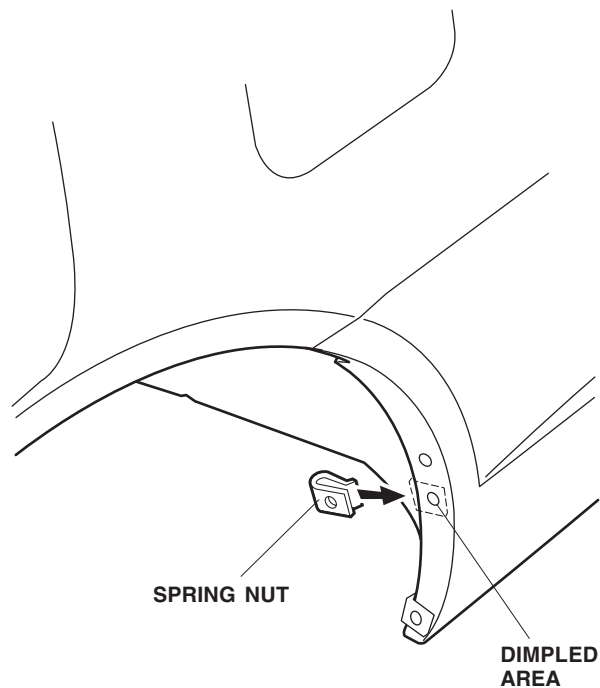

12. Position the splash guard and inner fender on the fender and rear bumper, then install the six self-tapping screws (the three from the kit and the three removed in step 3), and temporarily tighten them.
13. First, make sure there is no clearance between the inner fender and splash guard, and then securely tighten the three self-tapping screws and the one self-tapping screw (reused) in the order shown.
14. Securely tighten the remaining two self-tapping screws (reused), and install the four clips.

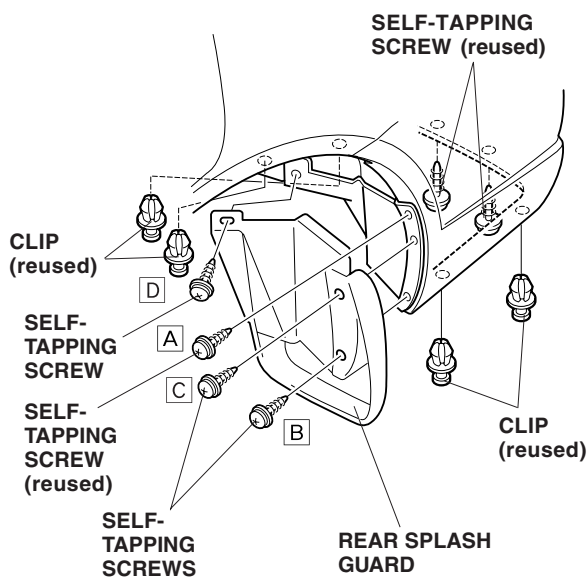

Right side

15. Slide the two spring nuts over the dimpled areas of the rear bumper. Press the new plastic grommet into the square hole in the fenderwell.
16. Position the splash guard on the fender and rear bumper, then install the three self-tapping screws and lightly tighten them.

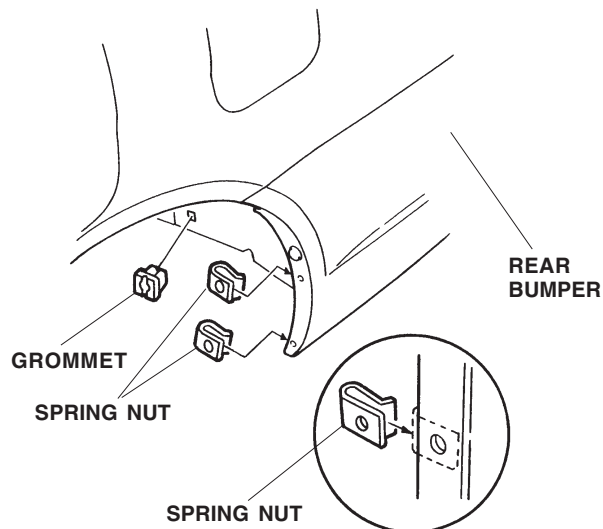

17. Check that there is no clearance between the vehicle body and the splash guard, then securely tighten the three self-tapping screws in the order shown.

