



# INSTALLATION INSTRUCTIONS

Accessory <b>CARGO NET</b> P/N 08L96-SNA-100	Application <b>2009 CIVIC</b> <b>4-DOOR Si</b>	Publications No. <b>All 40266</b>
		Issue Date <b>SEP 2008</b>

Put this information in the glove box with the vehicle's owner's manual

## PARTS LIST

Cargo net

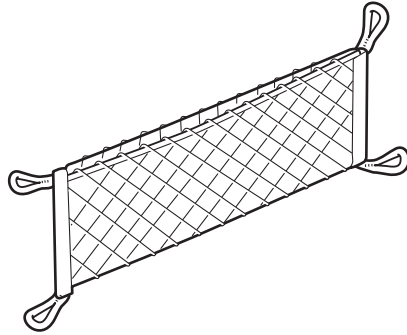

2 Anchors "A"

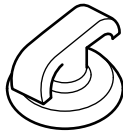

4 Anchors "B"



2 Bolts



4 Self-tapping screws



2 Rivet nuts

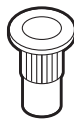

Template "L"

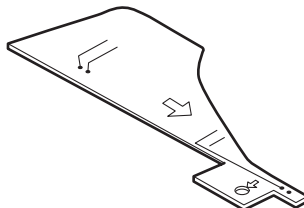

Template "R"

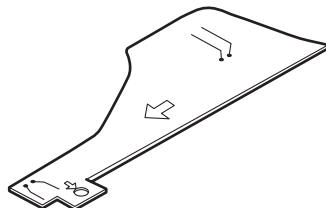

## TOOLS REQUIRED

- Flat-tip screwdriver
- Rivet nut tool
- Allen wrench
- 19 mm Wrench
- Utility knife
- Felt-tip pen
- Drill
- 3 mm, 5.5 mm, and 9 mm Drill bits
- Center punch
- Clip remover
- Eye protection

## INSTALLATION

**Customer Information:** The information in this installation instruction is intended for use only by skilled technicians who have the proper tools, equipment, and training to correctly and safely add equipment to your vehicle. These procedures should not be attempted by "do-it-yourselfers."

1. Temporarily install two bolts into each anchor "A" and four self-tapping screws into each anchor "B".

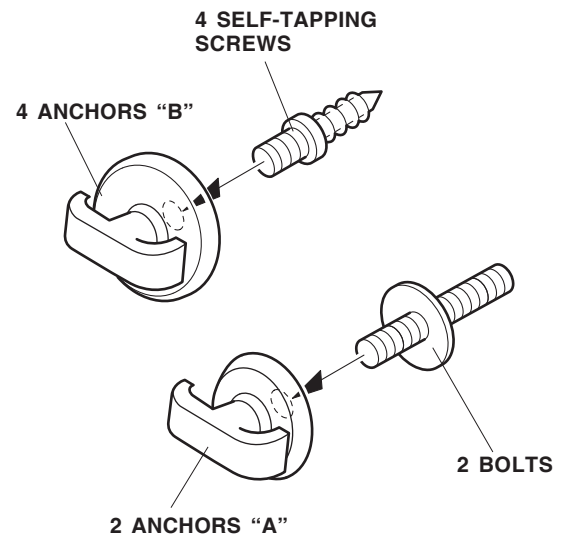

- Open the trunk, and remove the two clips from the trunk side lining.

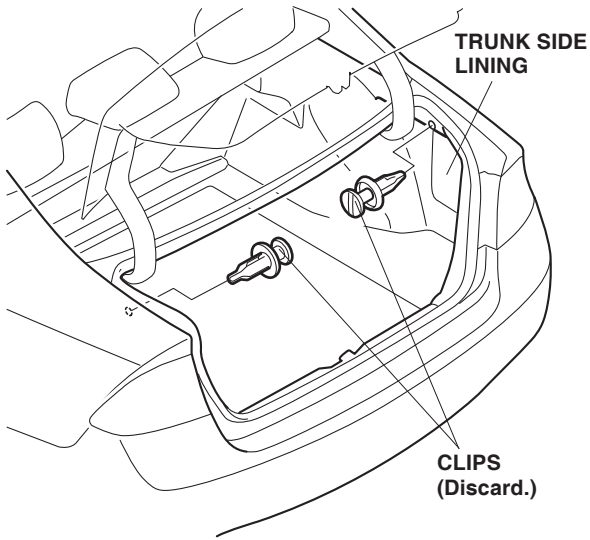

- While wearing eye protection, drill the two clip holes in the right and left trunk side panels to 9 mm. Remove any burrs, and apply touch-up paint to each hole.

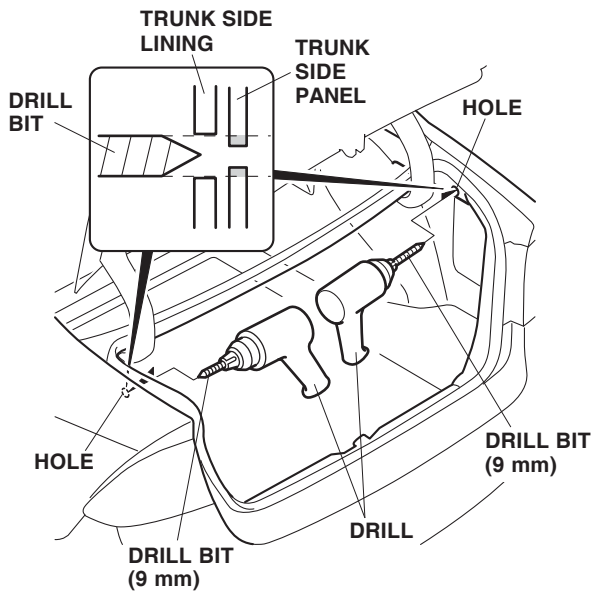

### Installing the Rivet nuts

- Thread the rivet nut onto the mandrel of the rivet nut tool as shown.

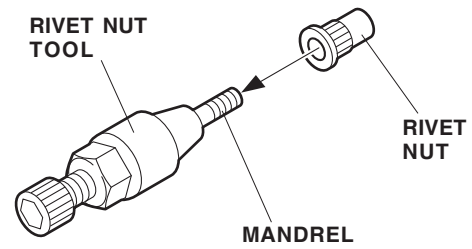

- Insert the rivet nut into the 9 mm hole in the vehicle panel.

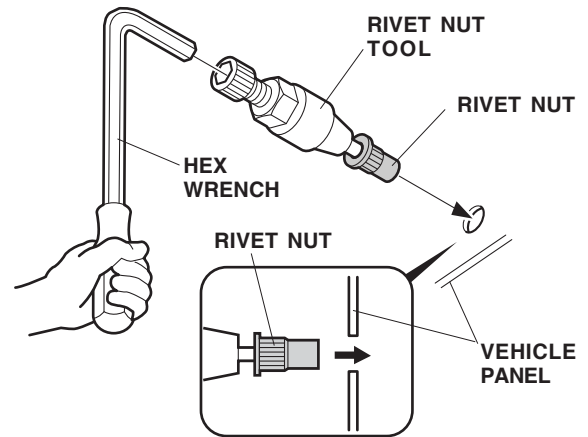

- While holding the rivet nut tool with the hex wrench, rotate the 19 mm wrench clockwise and install the rivet nut on the vehicle panel.

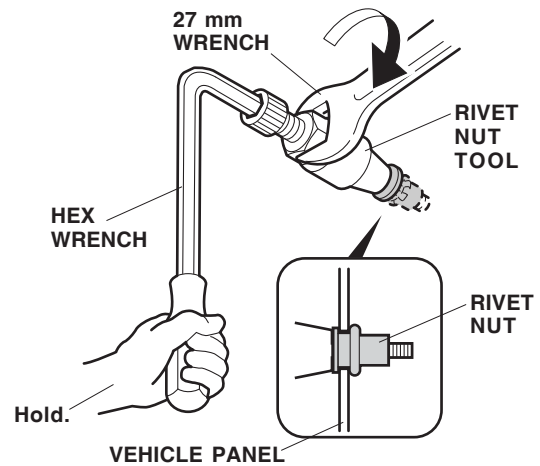

- Remove the rivet nut tool from the rivet nut by turning the hex wrench counterclockwise.
- Install a rivet nut into the other 9 mm hole using the above procedures.
- Install the two bolt/anchor "A" assemblies into the rivet nuts.

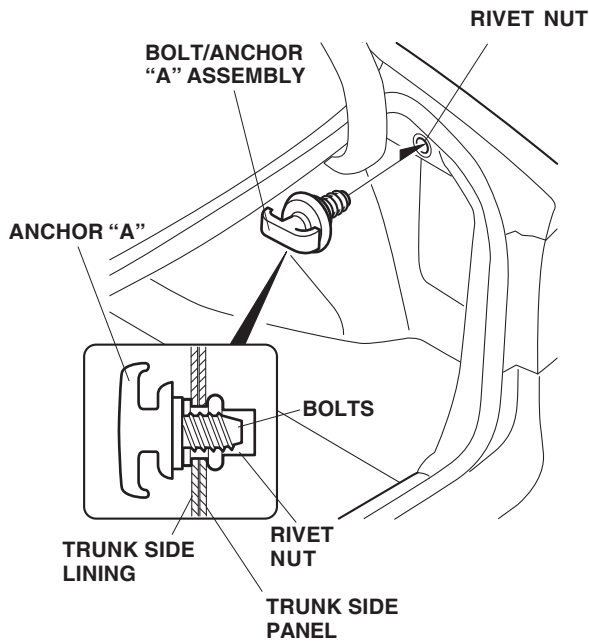

- Fold the rear seat-back forward by pulling the levers under the rear parcel shelf. Remove the trunk floor mat (two clips).

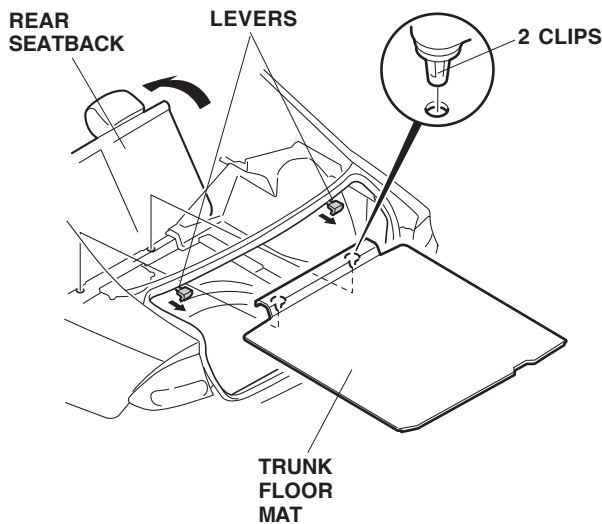

- Position template "R" on the right trunk side floor by aligning the clip with the hole and the edge parallel with the trunk side lining. Mark the floor using a felt-tip pen. Remove the template.

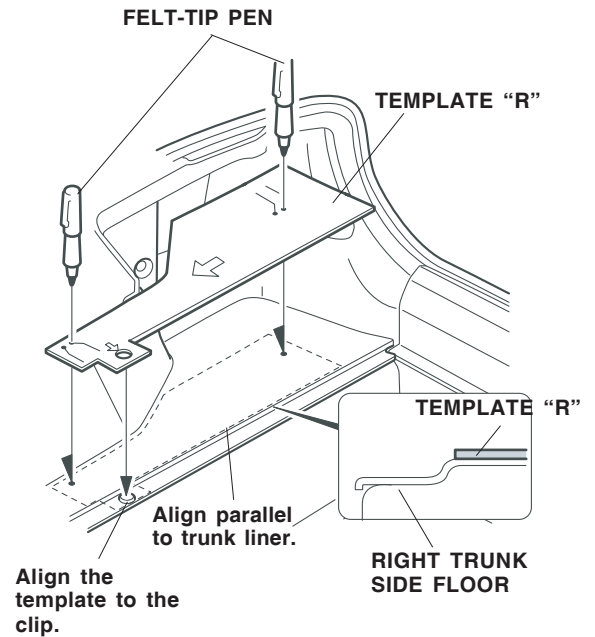

- Position template "L" on the left trunk side floor by aligning the clip with the hole and the edge parallel with the trunk side side lining. Mark the floor using a felt-tip pen. Remove the template.

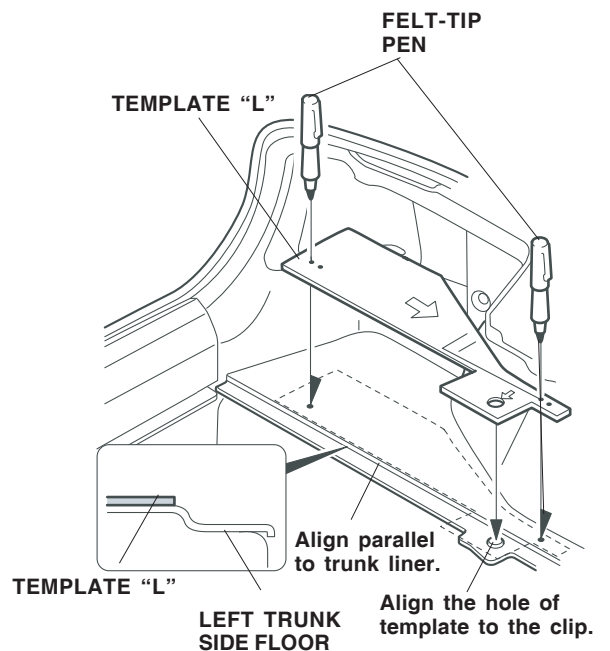

- Center-punch the marks you made. Lift the trunk liner and check that the center-punched marks are centered on the sheet metal rib. While wearing eye protection, drill a 5.5 mm hole through each mark. Start with a 3 mm drill bit, and finish with a 5.5 mm drill bit. Remove any burrs, and apply touch-up paint to each hole.

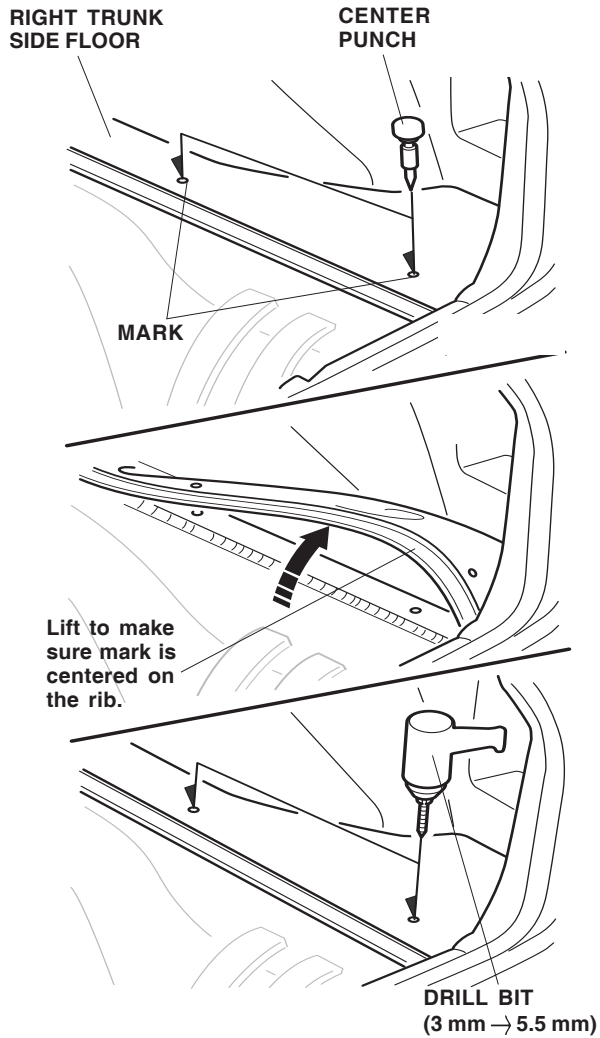

- Repeat step 13 to drill the left side of the vehicle.

- Install a self-tapping screw/anchor "B" assembly into each 5.5 mm hole you made.

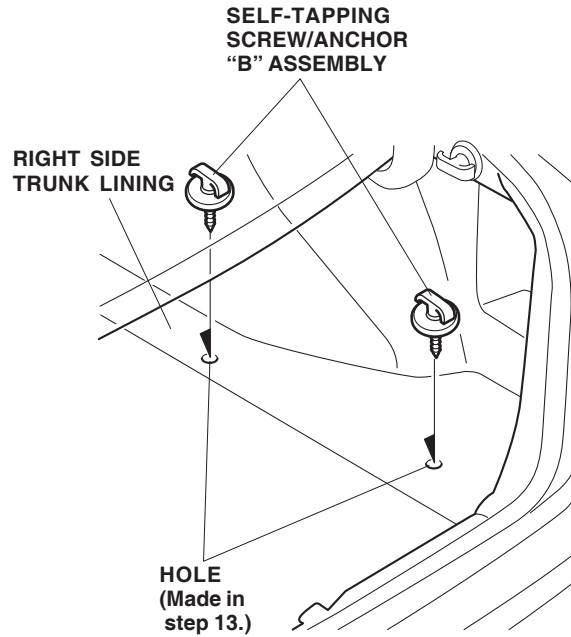

- Repeat step 15 to install the anchors on the left side of the vehicle.
- Install the cargo net to the anchors in the trunk. The cargo net can be installed in two different positions.

**BOLT/ANCHOR "A" ASSEMBLY**

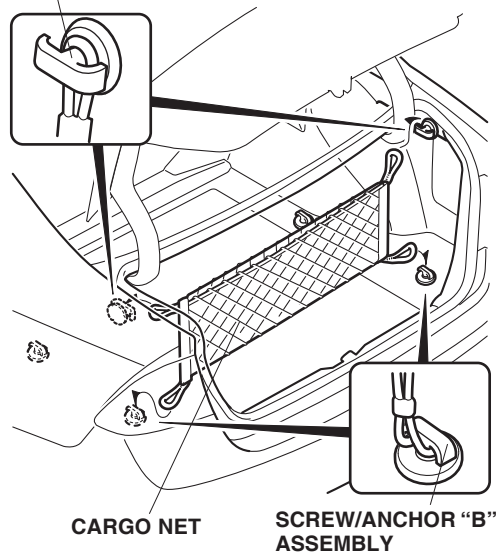

**SCREW/ANCHOR  
"B" ASSEMBLY**

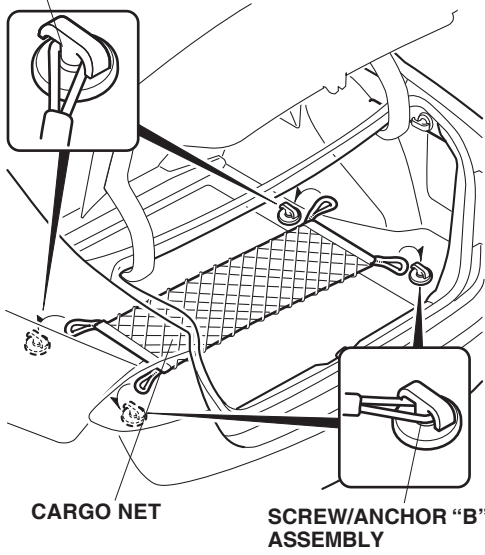

**NOTE:**

- Do not store large or fragile objects in the net.
- Objects with sharp edges or corners may damage the cargo net or the car. Wrap such objects in paper or a blanket so they will not contact the net directly.