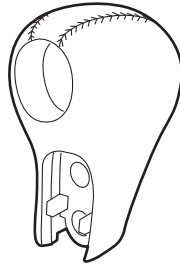

PARTS LIST

Select knob

**TOOLS AND SUPPLIES REQUIRED**

Phillips screwdriver

Flat-tip screwdriver

Shop towel

Silicone grease

Locktite thread lock (blue)

INSTALLATION

- Using a flat-tip screwdriver with a shop towel, pry off the O/D switch cover, and remove it.

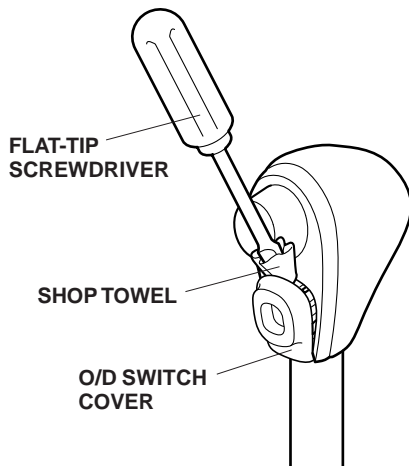

- Remove the O/D switch by expanding its locks, and remove the screws, shift lever button, spring, and shift lever knob.

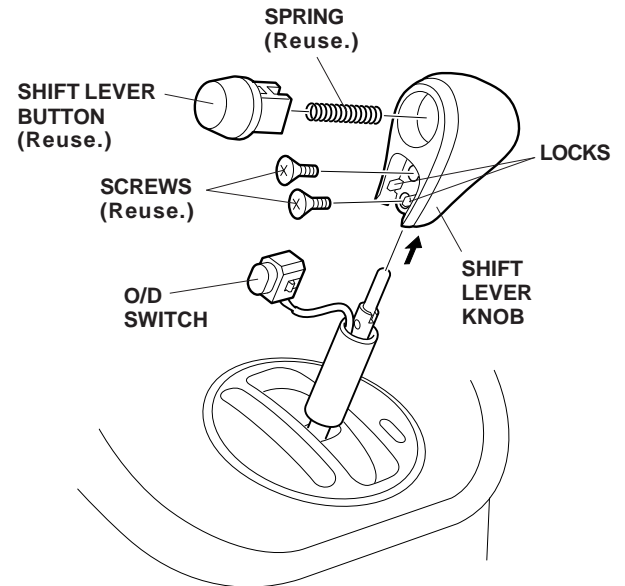

- Apply silicone grease to the shift lever button and the shift lever push rod, and install the spring, shift lever button, and the select knob. Apply blue locktite to screws, and install the screws to secure the select knob to the shift lever.

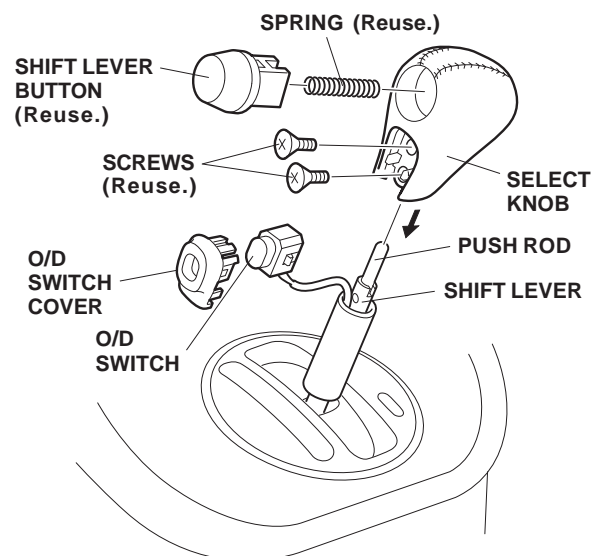

- Install the O/D switch and the O/D switch cover.