



INSTALLATION INSTRUCTIONS

Accessory

**SPLASH GUARDS
P/N 08P00-SHJ-101**

Application

2009 ODYSSEY

Publications No.

All 40252

Issue Date

AUG 2008

PARTS LIST

Right front splash guard

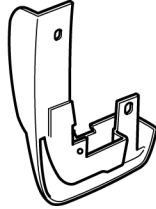

Left front splash guard

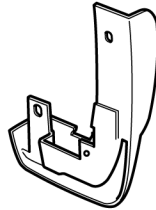

Right rear splash guard

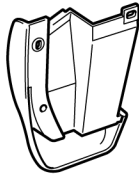

Left rear splash guard

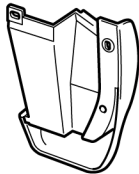

6 Self-tapping screws



2 Spring nuts



2 Square head grommets

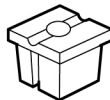

TOOLS REQUIRED

Stubby Phillips screwdriver

Pushpin

Floor jack

INSTALLATION

NOTE: Clean and wax the areas to be covered. Use a high-quality paste wax.

Installing the Front Splash Guard

1. Turn the steering wheel all the way counter-clockwise to provide access to the left front fenderwell.
2. Remove the two self-tapping screws from the left front inner fender.

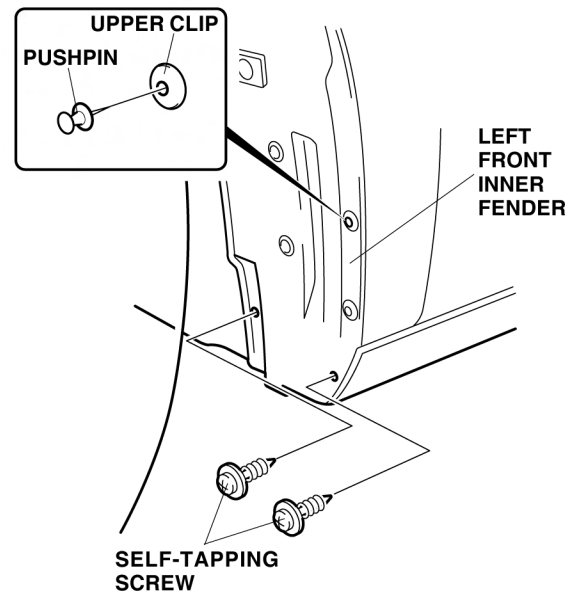

3. Using a pushpin, make a small hole through the center of the upper clip.

- Install the left front splash guard using the two self-tapping screws removed in step 2, and one self-tapping screw supplied with the kit. Do not tighten the self-tapping screws yet.

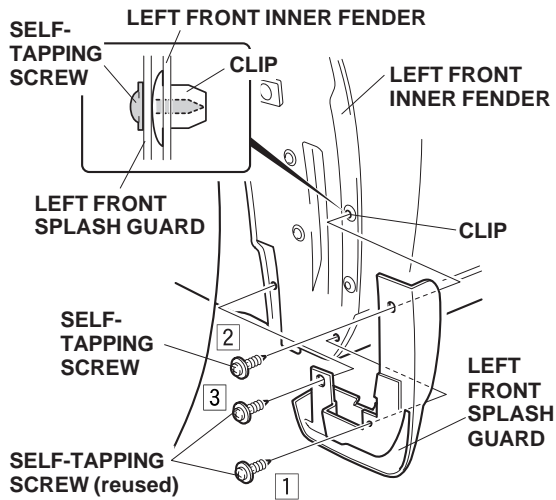

- While holding the left splash guard against the fender, tighten the self-tapping screws in the order shown.
- Turn the steering wheel all the way clockwise and repeat steps 2 thru 4 to install the right front splash guard.

Installing the Rear Splash Guard

- Using a floor jack, lift up the left rear side of the vehicle according to the service manual.
- Remove the self-tapping screw from the rear bumper. Using a pushpin, make a hole through the center of the recess.

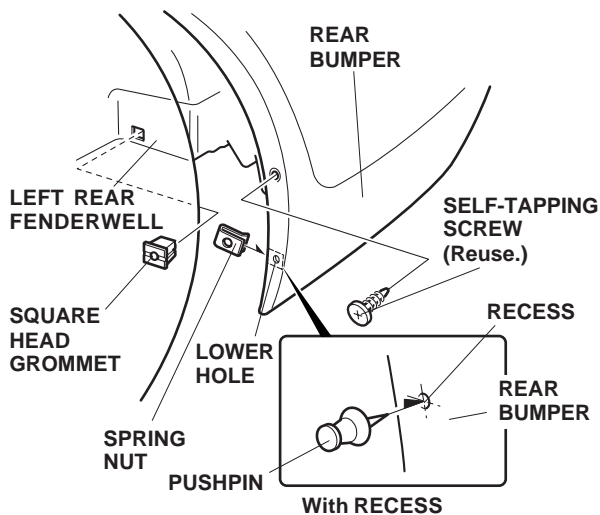

- Install one square head grommet into the hole in the left rear fenderwell. Slide one spring nut over the hole you made in step 8 in the rear bumper.

- Position the left rear splash guard on the left rear fenderwell and rear bumper, and loosely install one self-tapping screw you removed, and the two self-tapping screws supplied with the kit.

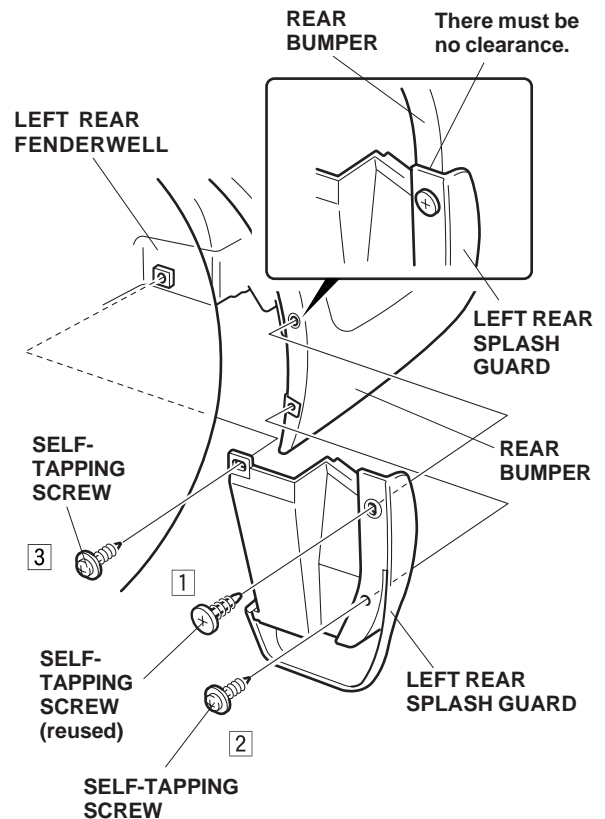

- Hold the left rear splash guard against the fenderwell and check that there is no clearance between the splash guard and rear bumper. Tighten the three self-tapping screws in the sequence shown.
- Repeat steps 7 thru 11 to install the right rear splash guard.