

HONDA

INSTALLATION INSTRUCTIONS

Accessory
Honda MUSIC LINK

Application
2007 RIDGELINE

Publications No.
All 39846
Issue Date
JUNE 2008

PARTS LIST

Attachment Kit
P/N:08A28-0J1-800

Adapter bracket A
(Not used)

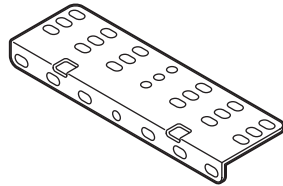

2 Adapter brackets B



Grommet
(Not used)



2 Screws, 4 x 10 mm
(Not used)



2 Bolts, 5 x 8 mm



2 Washer-screws, 5 x 16 mm



2 Flange bolts, 6 x 12 mm
(Not used)

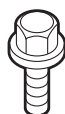

2 Flange nuts, 4 mm
(Not used)



2 Flange nuts, 5 mm



2 Flange nuts, 6 mm
(Not used)



4 Plain washers, 5 mm
(Not used)



2 Screw caps, 4 mm
(Not used)



2 Wire ties with clip
(Not used)

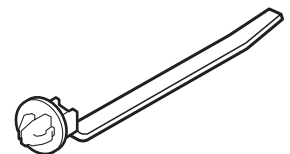

8 Wire ties

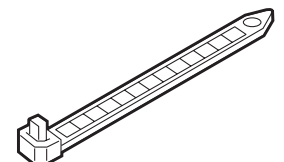

4 Urethane tapes

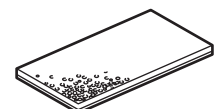

2 Cushion tapes

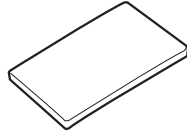

Honda Music Link Adapter Kit (sold separately)
P/N:08A28-1J1-100

Adapter unit

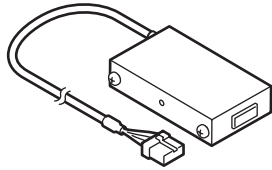

Music Link harness

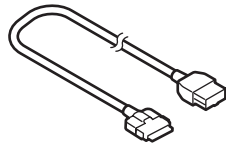

Accessory User's Information Manual

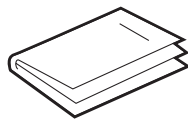

Bus cable 2-port (sold separately)
P/N: 08A31-0F1-000

Bus cable 2-port

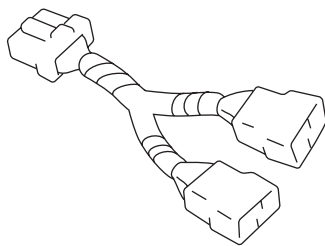

TOOLS AND SUPPLIES REQUIRED

- Phillips screwdriver
- Flat-tip screwdriver
- Drill
- 3 mm Drill bit
- 15 mm Hole saw
- Pushpin
- 10 mm Combination wrench
- Ratchet
- 8 mm and 10 mm Sockets
- Isopropyl alcohol
- Shop towel
- Tape measure
- Utility knife
- Eye protection (face shield, safety goggle, etc.)
- Felt-tip pen
- Masking tape
- White plastic trim tool

Illustration of the Honda Music Link Installed on the Vehicle

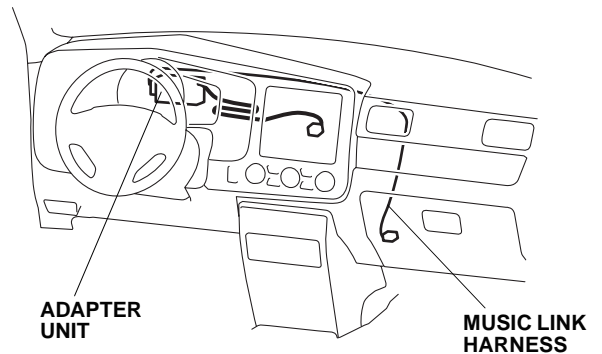

INSTALLATION

Customer Information: The information in this installation instruction is intended for use only by skilled technicians who have the proper tools, equipment, and training to correctly and safely add equipment to your vehicle. These procedures should not be attempted by "do-it-yourselfers."

1. Make sure you have the anti-theft code for the radio, then write down the radio station presets.
2. Disconnect the negative cable from the battery.

Removing the vehicle parts

- Remove the instrument panel (nineteen clips and disconnect the vehicle connectors).

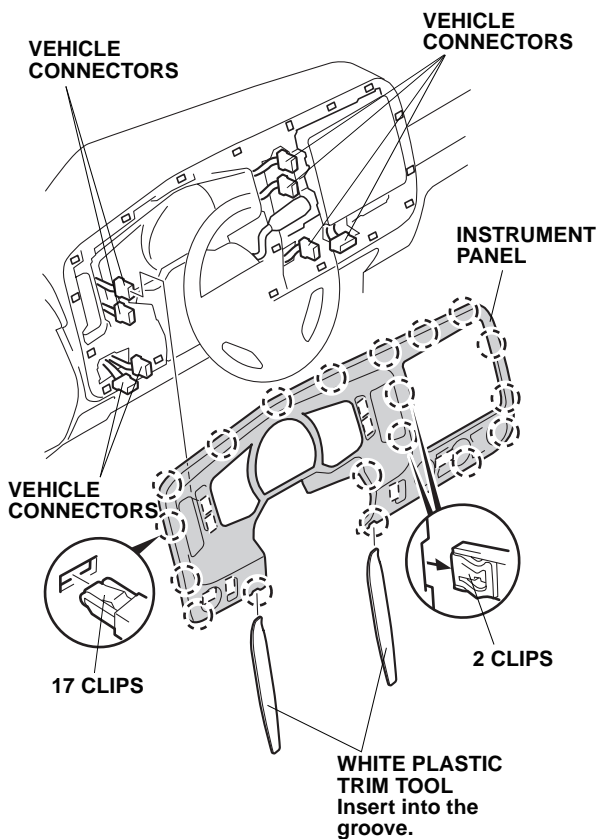

- Remove the meter assembly (four self-tapping screws, and disconnect the vehicle connectors).

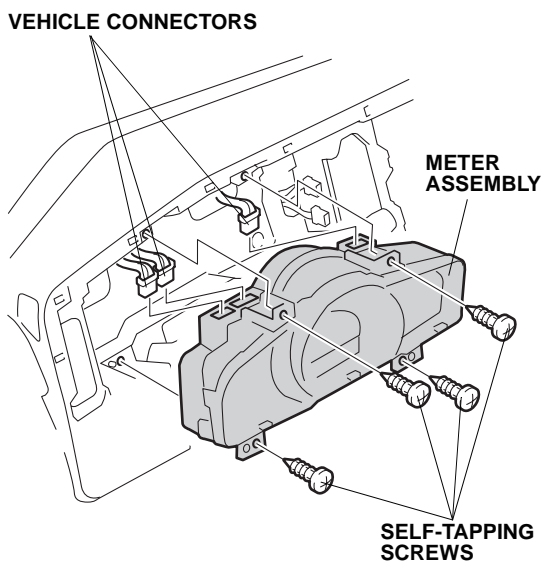

- Remove the audio unit (five bolts, pull the audio unit out, and disconnect the vehicle connectors).

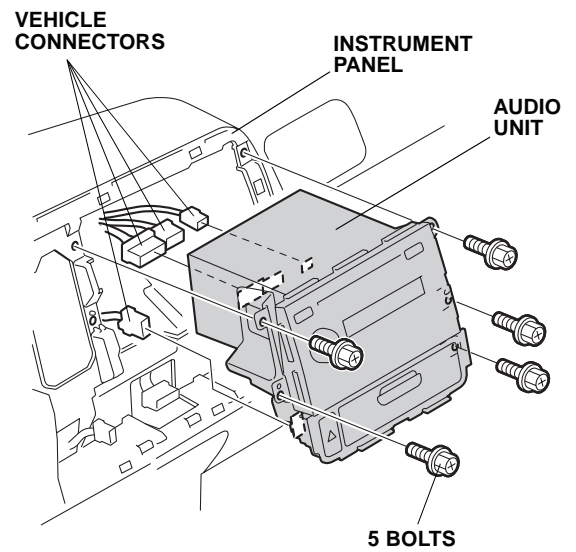

- Remove two stoppers (four retaining tabs).
- Release the upper part of the glove box (one damper rod).

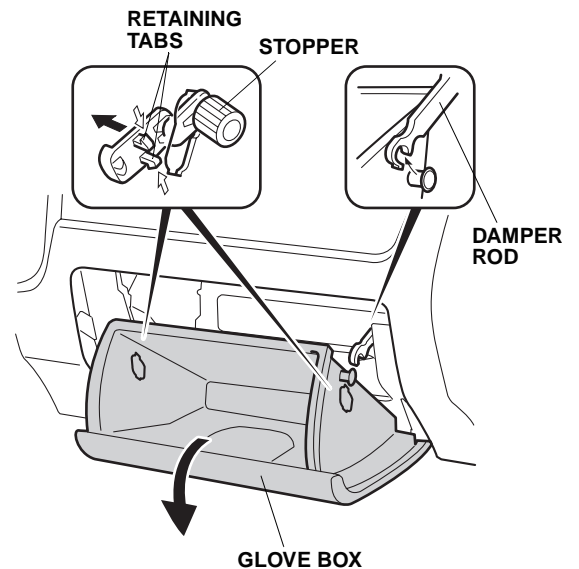

Installing the adapter unit and routing the harness

8. Attach masking tape to the Music Link harness at the indicated position.
9. Cut two urethane tapes in half and attach four pieces to the Music Link harness as shown.

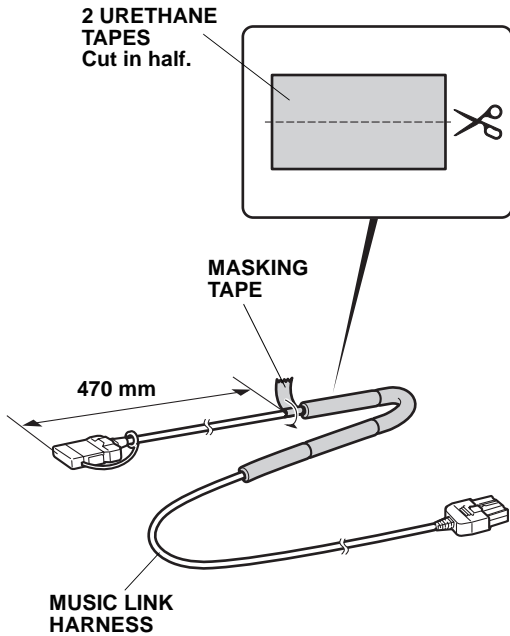

10. Connect the Music Link harness connector to the adapter unit and secure two adapter brackets B to the adapter unit with two 5 x 8 mm bolts.

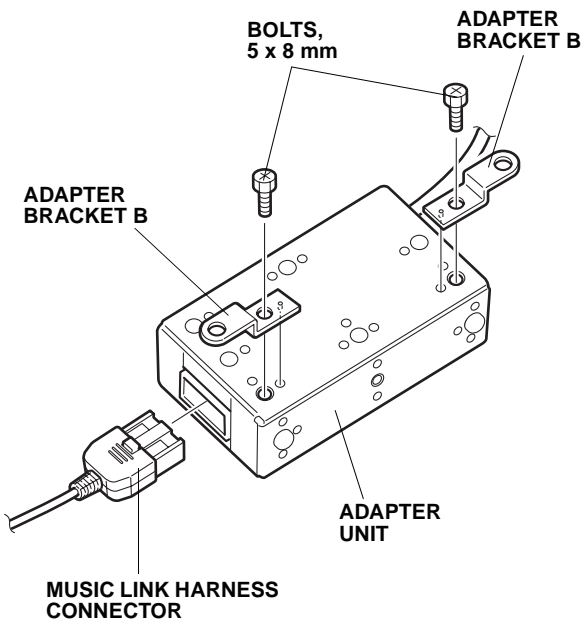

11. Using isopropyl alcohol on a shop towel, thoroughly clean the area where the cushion tape will attach. Secure the Music Link harness to the adapter unit with one cushion tape.

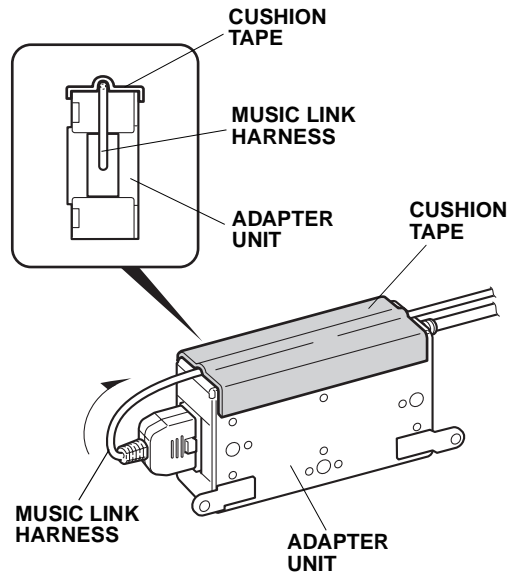

12. Using isopropyl alcohol on a shop towel, thoroughly clean the area where the cushion tape will attach. Attach one cushion tape to the adapter unit.

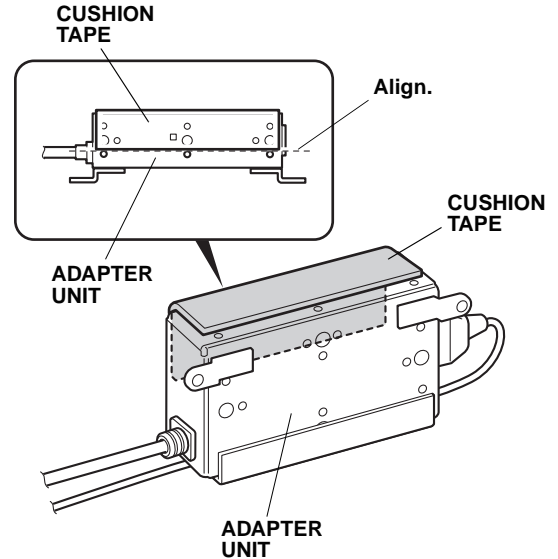

13. Using a felt-tip pen, mark the indicated positions on the meter assembly opening.
14. Using a pushpin, pierce the marks made in step 13.

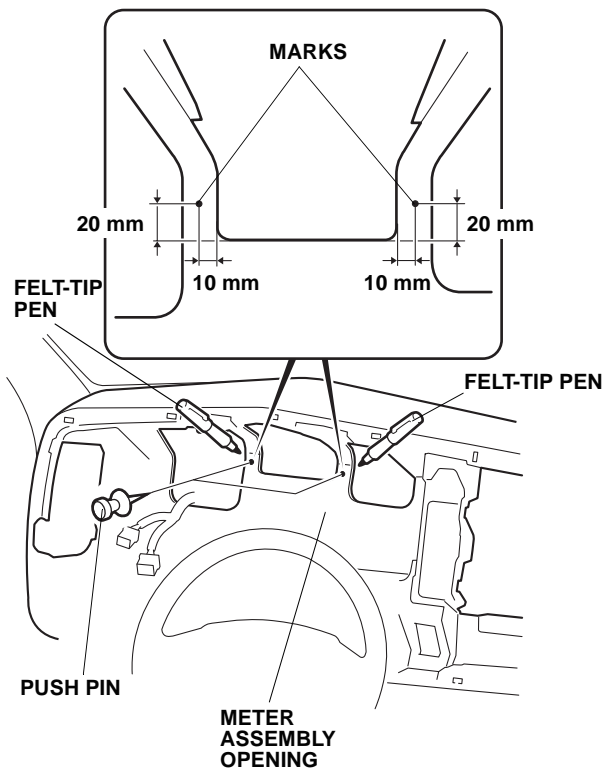

15. Place a shop towel as shown. Drill at the positions marked in step 14 with a 3 mm drill and then with a 6 mm drill. Remove any burrs.

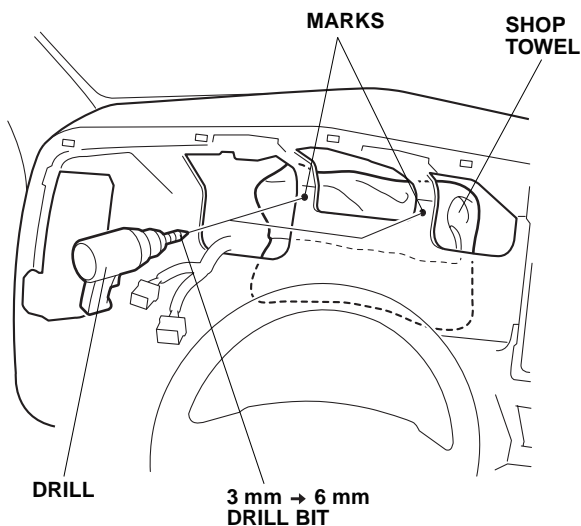

16. Install the adapter unit to the instrument panel with two 5 x 16 mm washer-screws and two 5 mm flange nuts.

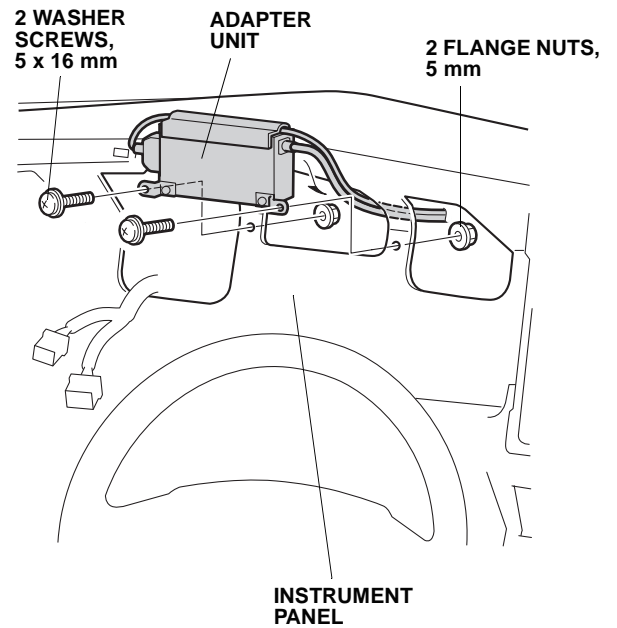

17. Route the Music Link harness as shown.
18. Route the adapter unit harness from the meter assembly opening to the audio unit opening.

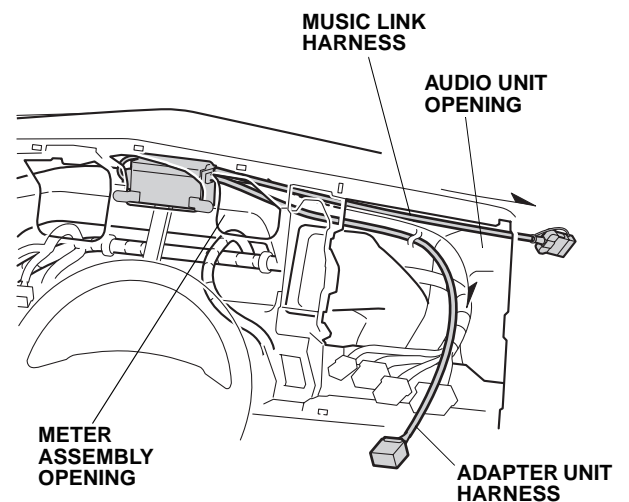

- Align the adapter unit connector with the vehicle 20-pin connector at the audio unit opening and secure the adapter unit harness and the Music Link harness to the vehicle harness with one wire tie.

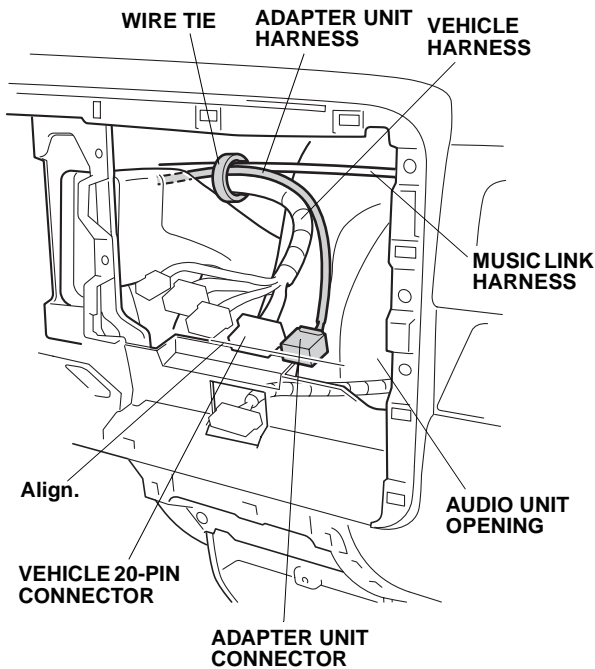

- Route the Music Link harness to the glove box opening.

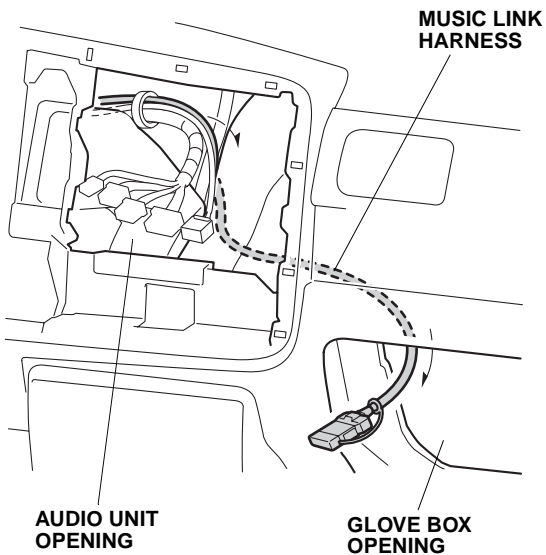

- Secure the adapter unit harness and the Music Link harness to the vehicle harness with one wire tie.

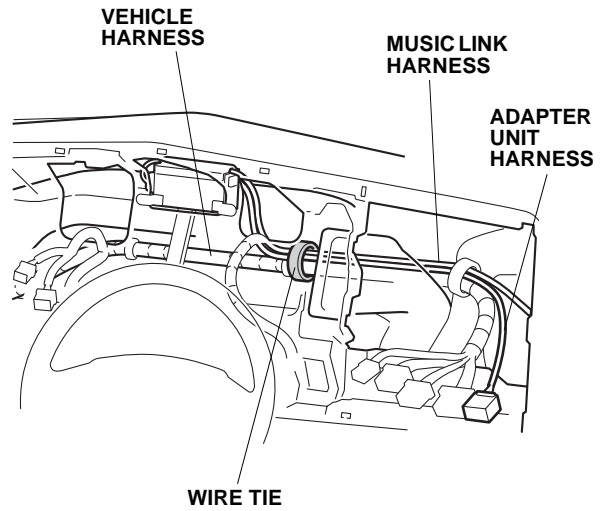

If the vehicle is equipped with the vehicle 14-pin connector or the other accessory 14-pin connector, go to step 22; if not, go to step 24.

- Connect the adapter unit connector and the other 14-pin connector to the bus cable 2-port 14-pin connectors.
- Wrap one urethane tape around each bus cable 2-port 14-pin connector.

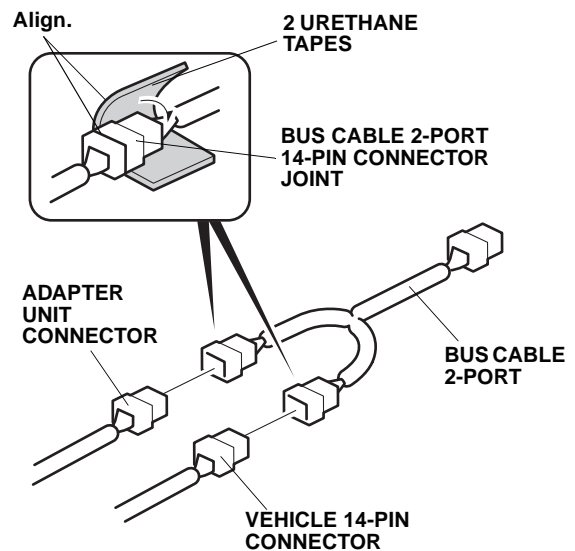

24. Connect the vehicle connectors and adapter unit harness 14-pin connector (or bus cable 2-port 14-pin connector) to the audio unit, and reinstall the audio unit.

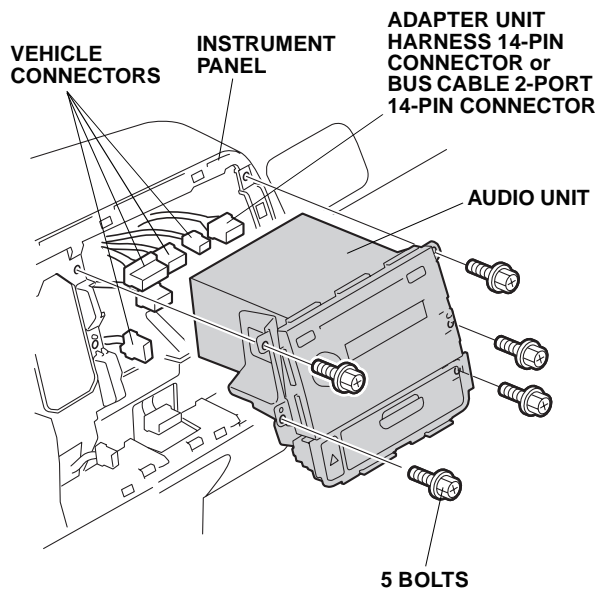

CD Tuner

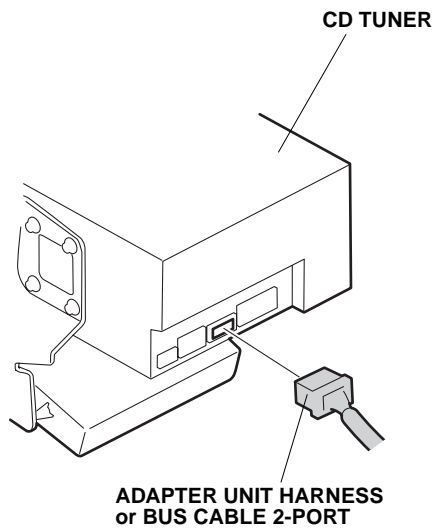

6-CD Tuner

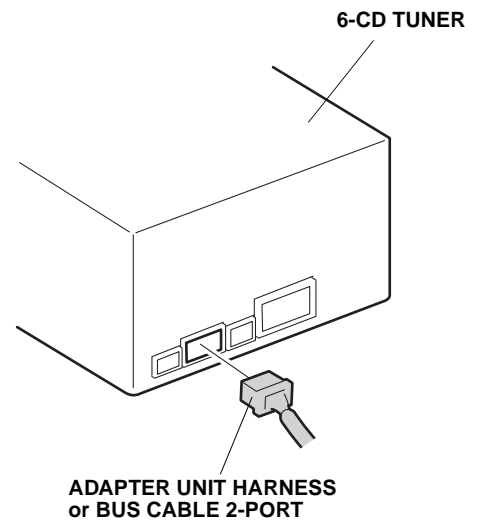

Navigation Unit

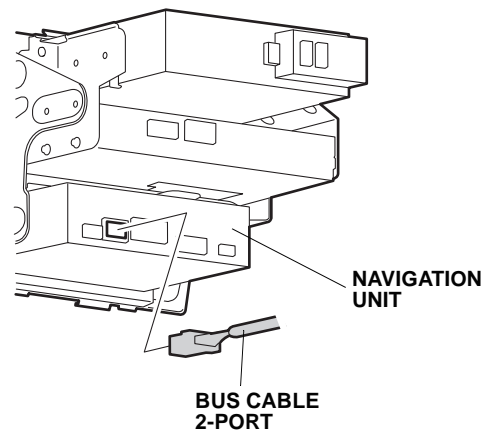

25. Secure the Music Link harness to the vehicle harness with one wire tie at the masking tape attached in step 8.

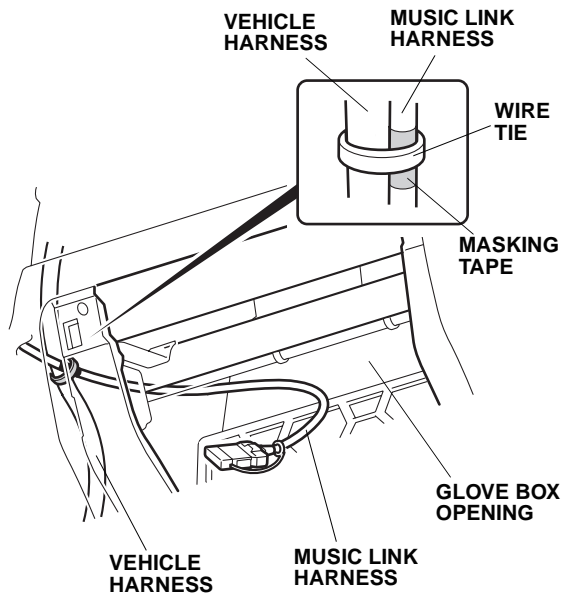

26. Store the Music Link harness inside the glove box.

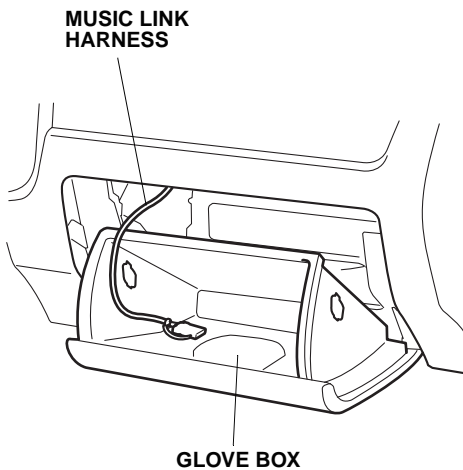

27. Check that all wire harnesses are routed properly and all connectors are plugged in.
28. Reconnect the negative cable to the battery.
29. Reinstall all removed parts.
30. Enter the customer's radio anti-theft code, and reset the radio station presets, and the clock.
31. **Turn the radio unit ON. Set mode to Honda Music Link by pressing "CD" until display "CDC" or "CD4" is shown on the radio display. Check that the mode changes to the CD changer mode properly ("CDC" or "CD4" is shown on the radio display).**

NOTE: When the battery is disconnected, the driver's window AUTO function is disabled.

- Start the engine. Push down on the driver's window switch until the window is fully open.
- Pull up on the driver's window switch to close the window completely, then hold the switch for 1 second or more.
- Lower and raise the driver's window to check operation of the driver's window AUTO function.