



INSTALLATION INSTRUCTIONS

Accessory
REAR CAMERA ATTACHMENT (EX-L WITH NAVI)

Application
2008 RIDGELINE

Publications No.
All 36587-38878

Issue Date
FEB 2008

PARTS LIST

Attachment Kit
P/N: 08B21-SJC-102

Rear camera trim

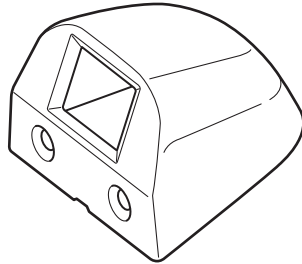

Rear camera bracket

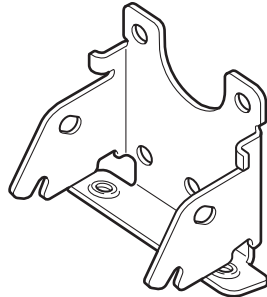

Rear camera subbracket

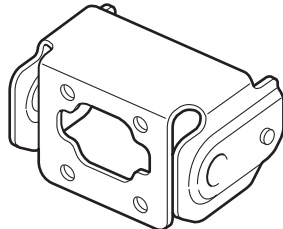

Harness clamp bracket A

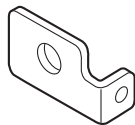

Harness clamp bracket B

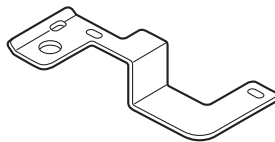

Rear camera subharness

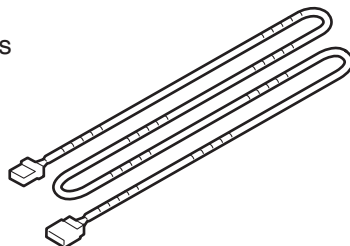

Template

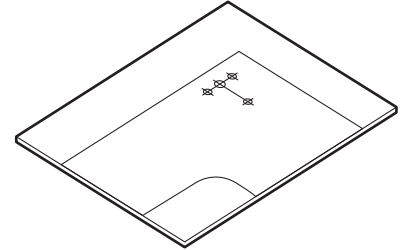

19 Wire ties

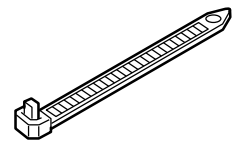

10 Small wire ties

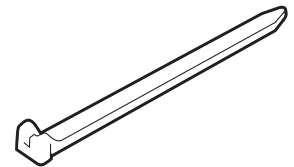

6 Wire ties with clip

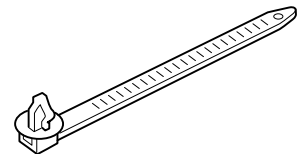

6-Pin connector

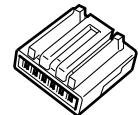

Grommet

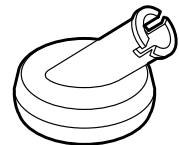

2 Clear adhesive tapes

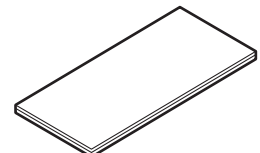

3 Blind nuts



2 EPT sealers

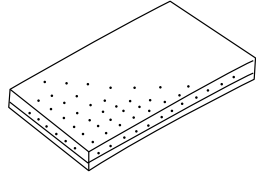

4 Cushion tapes

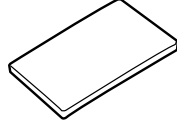

2 Socket bolts, 4 x 10 mm

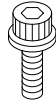

3 Washer screws, 4 x 12 mm



2 Washer screws, 4 x 6 mm



7 Clips



Round grommet



6 Oval grommets



Accessory user's information manual

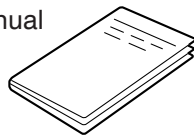

Rear Camera Kit (sold separately)
P/N: 08A57-SJC-100

Rear camera

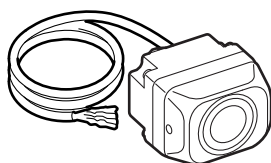

TOOLS AND SUPPLIES REQUIRED

Phillips screwdriver

Flat-tip screwdriver

10 mm Combination wrench

Ratchet

10 mm, 12 mm, and 14 mm Socket

Torque wrench

File

Isopropyl alcohol

Shop towel

Tape measure

Drill

3 mm, 8 mm, and 10 mm Drill bits

Utility knife

T40 and T50 Torx bit

KTC trim tool

Scissors

Tape

Electrical tape

Wire

3 mm Hex wrench

Illustration of the Rear Camera Installed on the Vehicle

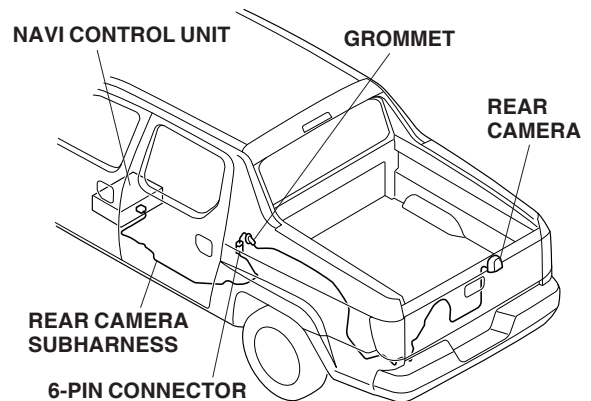

INSTALLATION

Customer Information: The information in this installation instruction is intended for use only by skilled technicians who have the proper tools, equipment, and training to correctly and safely add equipment to your vehicle. These procedures should not be attempted by "do-it-yourselfers."

1. Make sure you have the anti-theft code for the radio, then write down radio station presets.
2. Disconnect the negative cable from the battery.

- Remove the fuel fill door release handle. Remove the left front door sill trim (three clips and three retaining tabs).

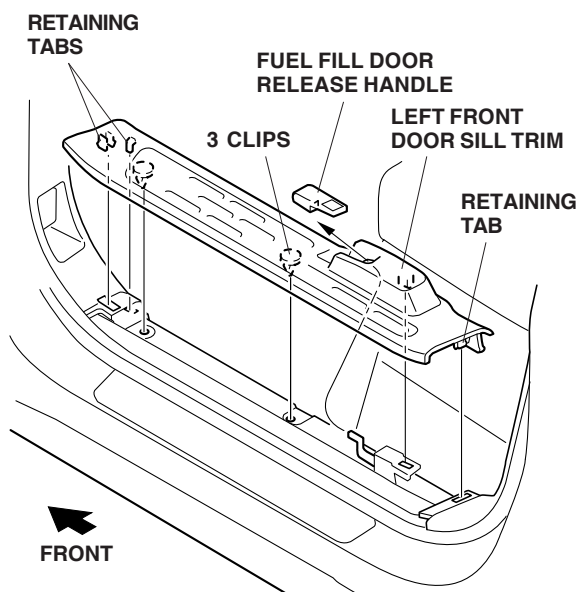

- Remove the left rear door sill trim (three clips and four retaining tabs).

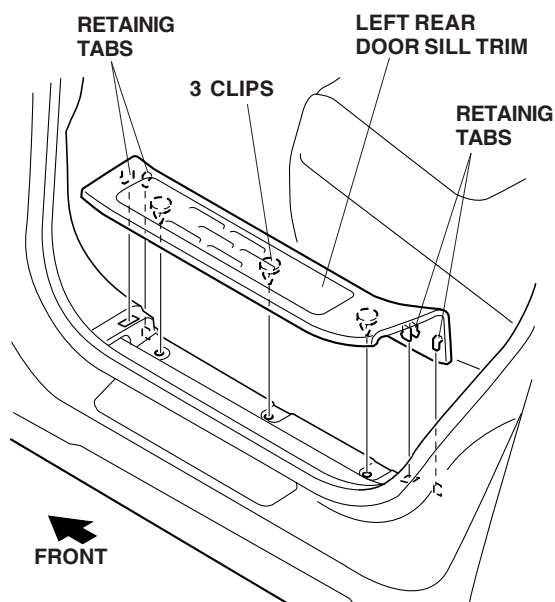

- Pull away the weatherstrip from the B-pillar lower trim panel. Remove the left seat belt lower anchor bolt cover and remove the lower anchor bolt. Remove the left B-pillar lower trim panel by pulling out toward you as shown.

Seat belt anchor bolt torque:
30 to 35 N·m (22 to 25 lbs)

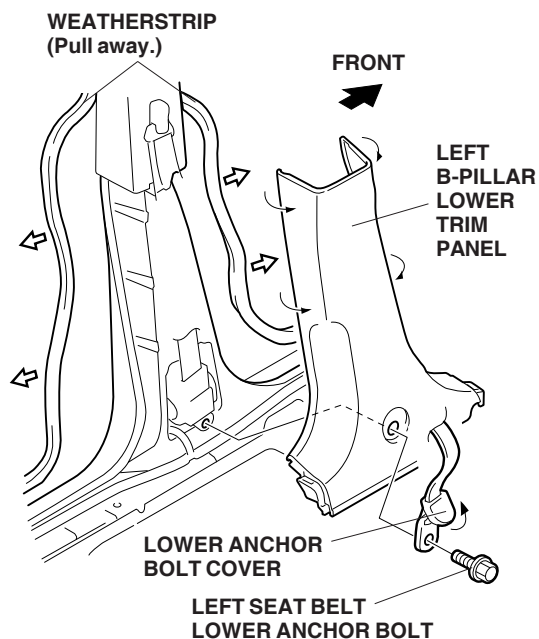

- Remove the driver's seat frame rear cover (two clips and two hooks).

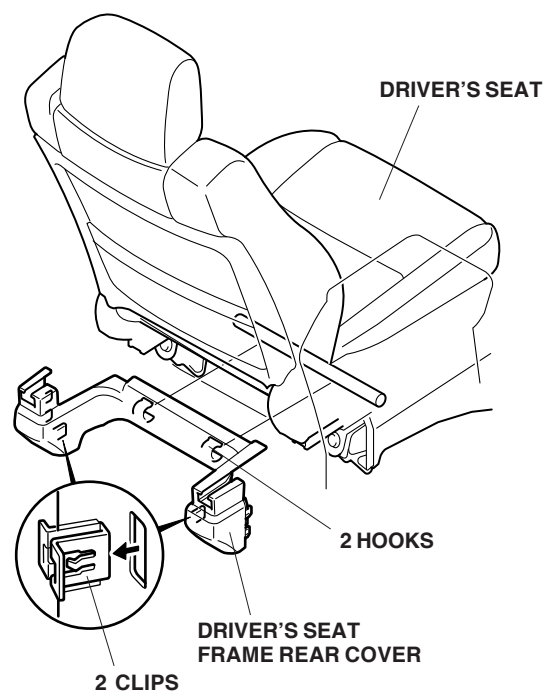

7. Lift up the rear seats, and remove the rear seat under covers;
 - Remove the right rear seat under cover (four clips).
 - Remove the left rear seat under cover (five clips).

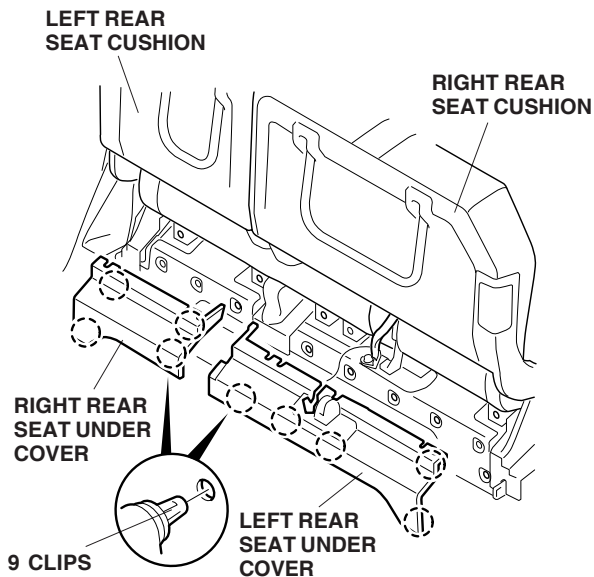

8. Remove the rear seat bracket covers;
 - Remove the left and right rear seat bracket covers (two clips for each cover).
 - Remove the center seat bracket cover (two clips and nine retaining tabs).

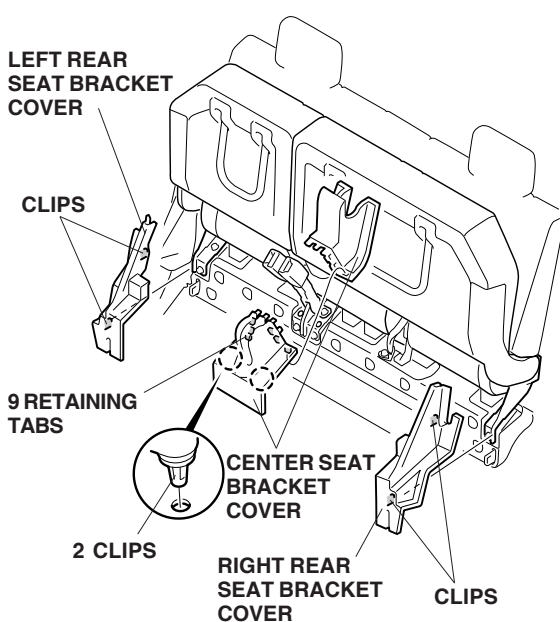

9. Remove the rear seat belt anchor bolt and eight seat anchor bolts.

Seat belt anchor bolt torque:
30 to 35 N·m (22 to 25 lbs)

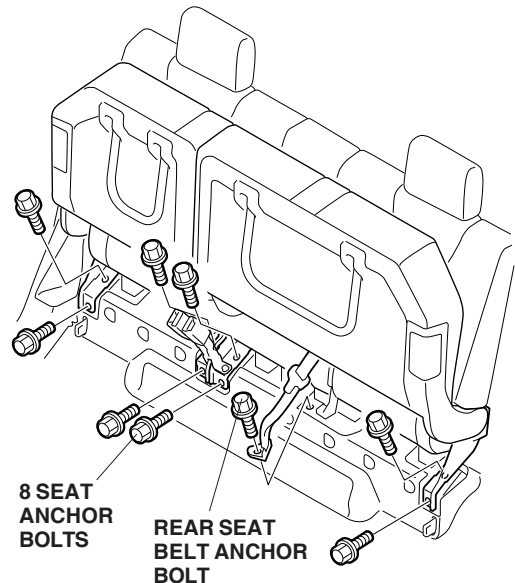

10. Remove the cap from the rear trim panel cover (four retaining tabs for each cover), and remove the rear seat.

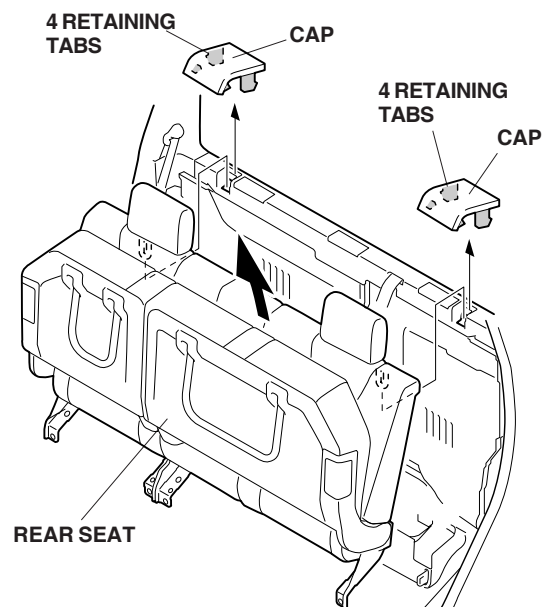

11. Remove the rear trim panel cover (eight clips and two retaining tabs).

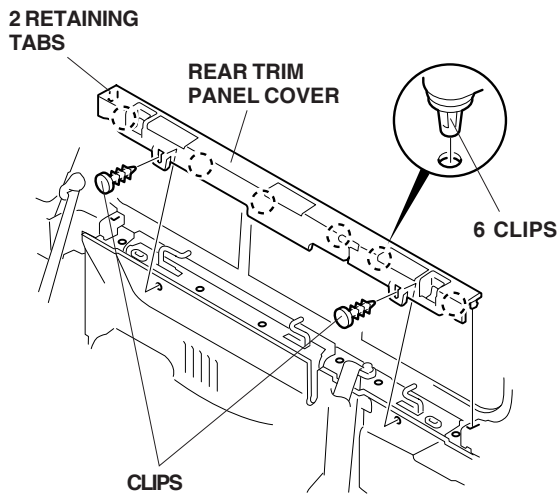

12. Remove the left rear seat belt upper anchor bolt cover (four retaining tabs), and remove the left rear seat belt upper anchor bolt.

Seat belt anchor bolt torque:
30 to 35 N·m (22 to 25 lbs)

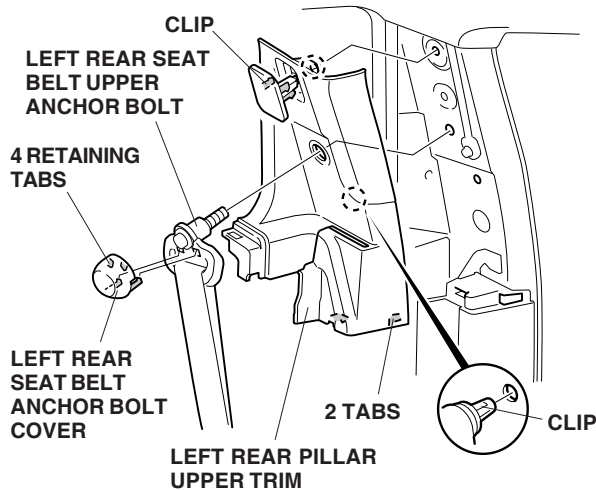

13. Remove the left rear pillar upper trim.

- With side airbag; pull the clip, and remove the left rear pillar trim by releasing the one clip.
- Without side airbag; remove the left rear pillar trim by releasing the two clips.

14. Remove the left rear lower anchor bolt cover, and remove the left rear seat belt lower anchor bolt.

Seat belt anchor bolt torque:
30 to 35 N·m (22 to 25 lbs)

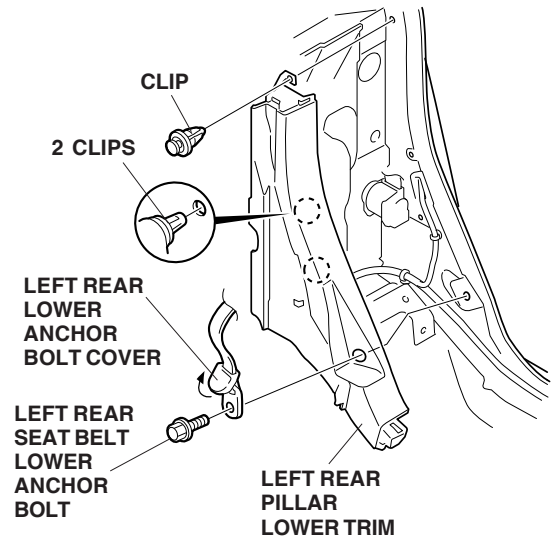

15. Remove upper clip, then pull the left rear pillar lower trim out toward you to release two clips.
16. Remove the left rear taillight (two bolts, two clips, and vehicle connector). Remove the right taillight the same way.

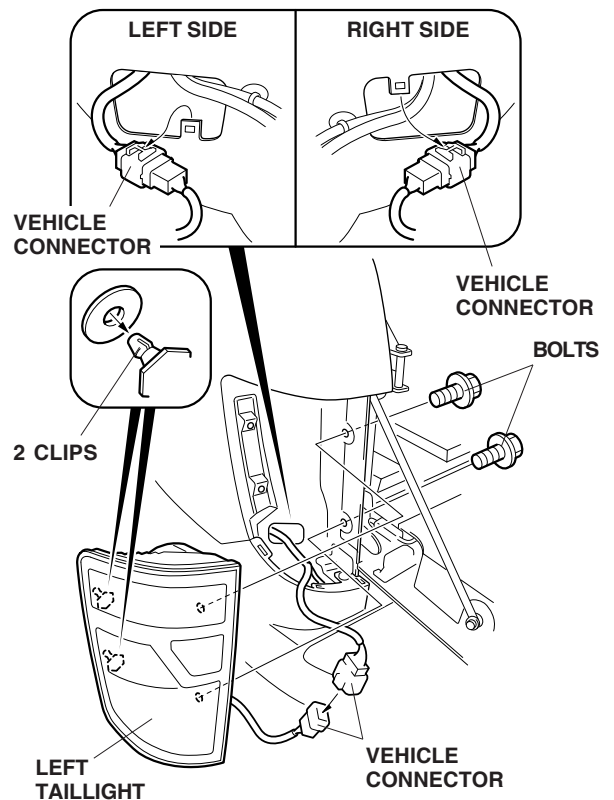

17. Remove the rear bumper:

- Remove the license plate (two bolts).
- Remove two bolts, six self-tapping screws, and six clips from the rear bumper.
- Pull the rear bumper toward you. Unplug the two vehicle connectors, and remove the rear bumper.
- Set the rear bumper on the blanket.

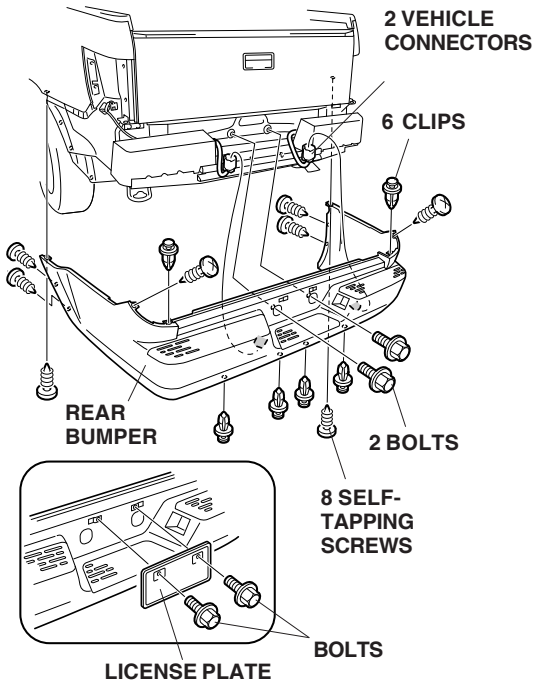

18. Remove the rear roof trim:

- Remove the roof trim nut covers (two retaining tabs for each cover).
- Remove the two nuts.

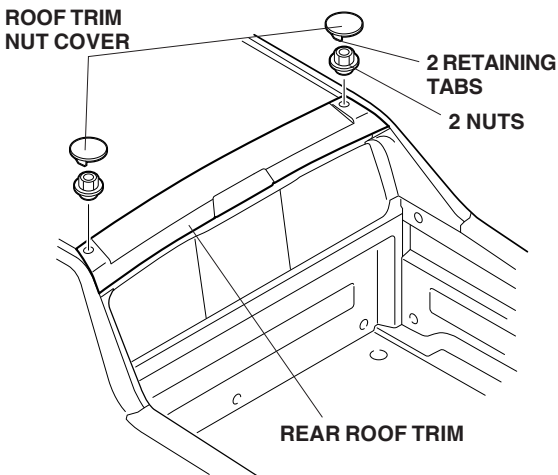

- Using a KTC trim tool, carefully pry up the front of the trim to release the three front clips. Start with the left clip and work towards the right clip.
- Gently lift the front of the trim to release the four rear clips.

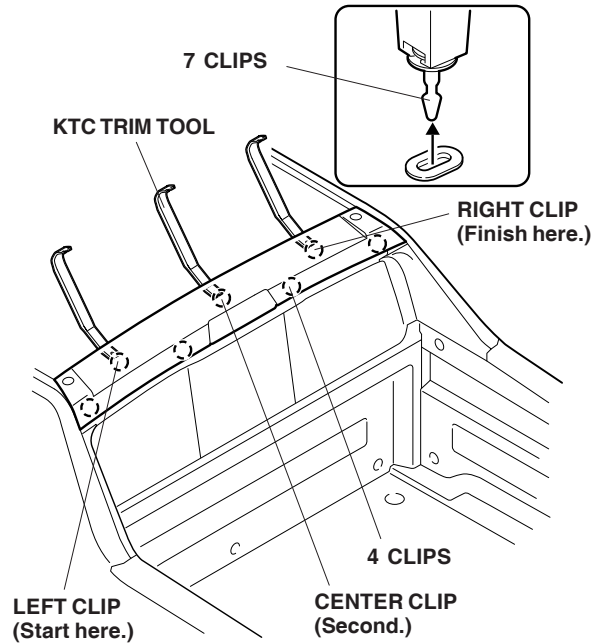

- Remove the antenna grommet from the roof, unplug the vehicle connector, and remove the rear roof trim.

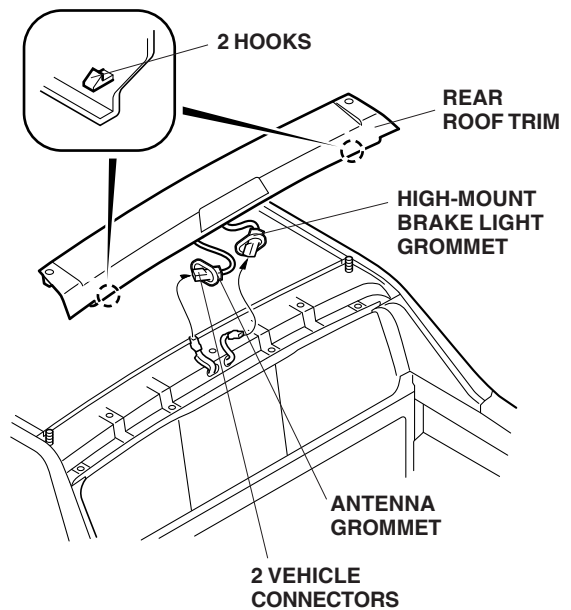

19. Remove and discard the grommets from the roof panel, and install the six oval grommets and one round grommet into the roof panel.

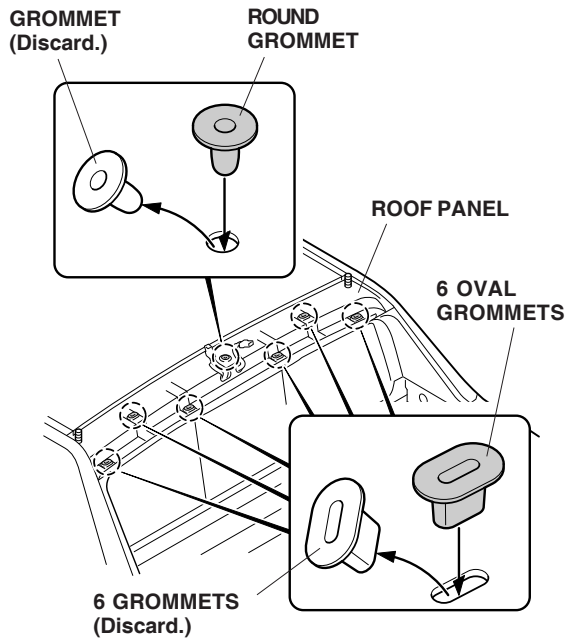

20. On the rear roof trim backside, remove and discard the clips from the rear roof trim, and install the seven clips to the rear roof trim.

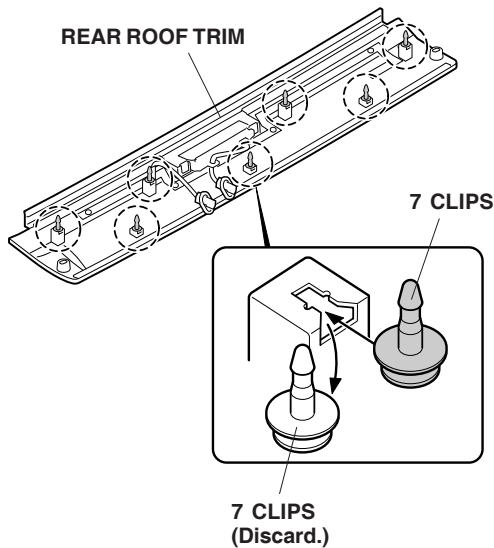

21. Remove the left C-pillar outer trim (slide rearward, and unplug the vehicle connector). Remove the clips from the body, and reinstall the clips to the left C-pillar outer trim.

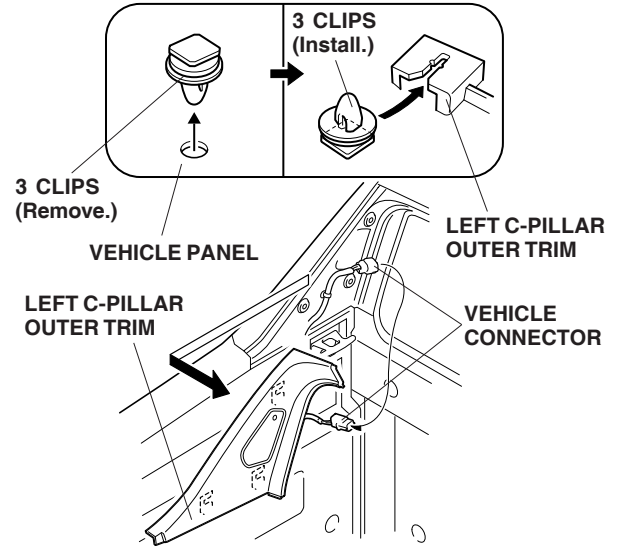

22. Remove the left front anchor (two TORX bolts).

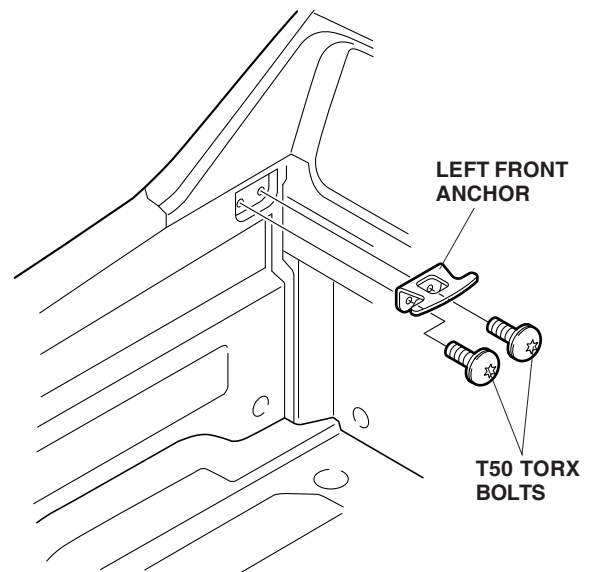

23. Remove the front bed panel (six TORX bolts).

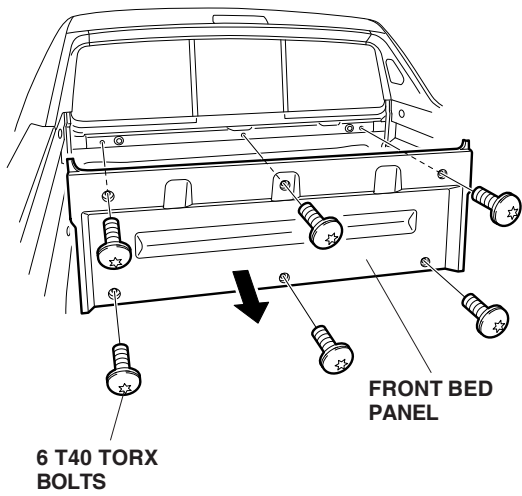

24. Remove the left bed rail trim:

- Remove the screw cover (four retaining tabs).
- Remove the self-tapping screw.
- Pull the left bed rail trim back to release the six clips, and remove the left bed rail trim.

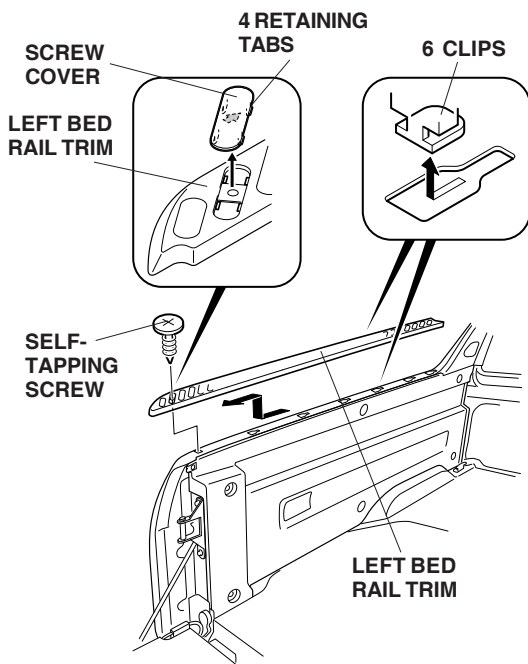

25. Remove the left lower bed light (one self-tapping screw, pull the light out towards you and unplug the vehicle connector).

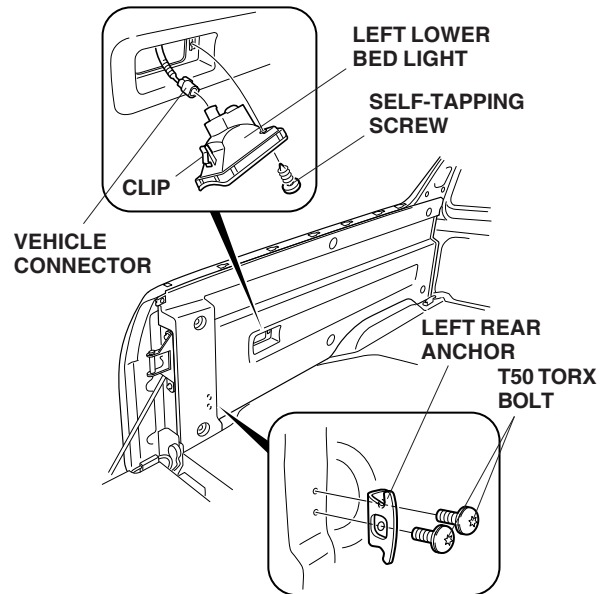

26. Remove the left rear anchor (two TORX bolts).

27. Remove the left side bed panel (six TORX bolts).

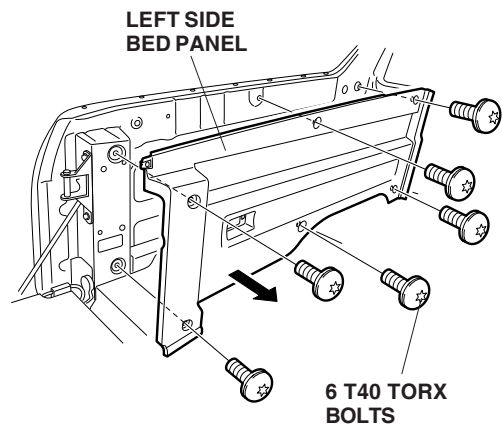

28. Remove the tailgate trim:

- Remove the four screws and release the one end clip on each side.
- Sharply push the tailgate to the right to release the 16 clips from the trim.
- Remove the 16 clips from the tailgate and reinstall the 16 clips to the tailgate trim in the direction shown.

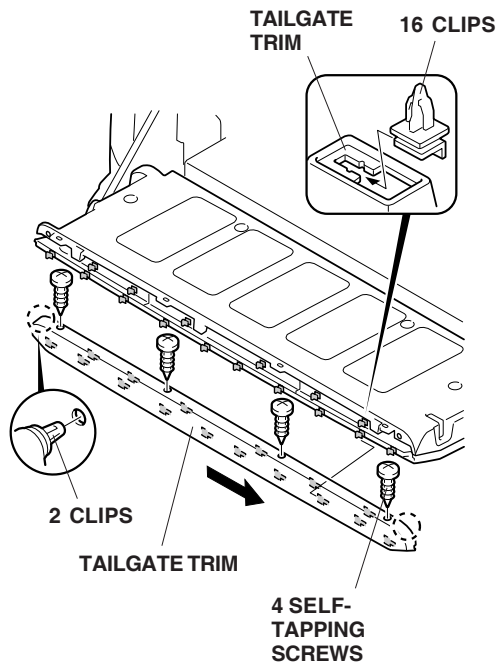

29. Remove the tailgate panel (seven TORX screws).

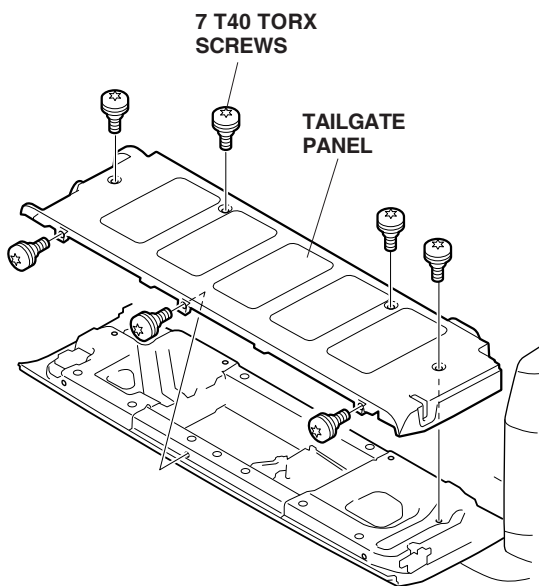

30. Get the template. Using a scissors, cut out the marked area from the template. Align the edge of the template with the edge of the tailgate as shown, and attach it to the tailgate tape.

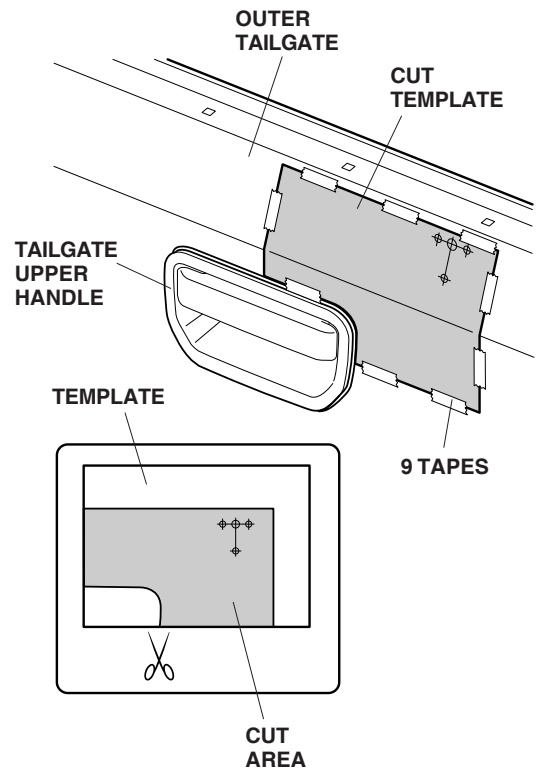

31. Center punch the tailgate at the marks on the template. Remove the template.

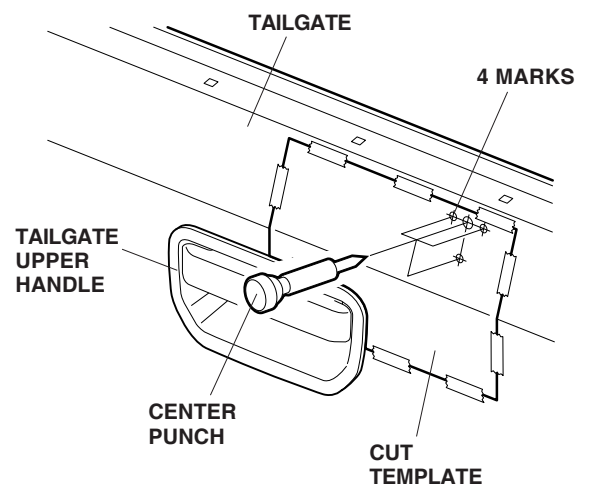

32. Drill three 8 mm holes and one 10 mm hole in the tailgate.

- Wrap tape around a 3 mm drill bit, 8 mm drill bit, and a 10 mm drill bit 10 to 15 mm from the end or use a drill stop.
- While wearing eye protection, drill a 3 mm hole, then an 8 mm hole in all four locations. Drill a 10 mm hole only in the upper center hole.
- Remove any burrs, and apply touch-up paint to all of the holes.

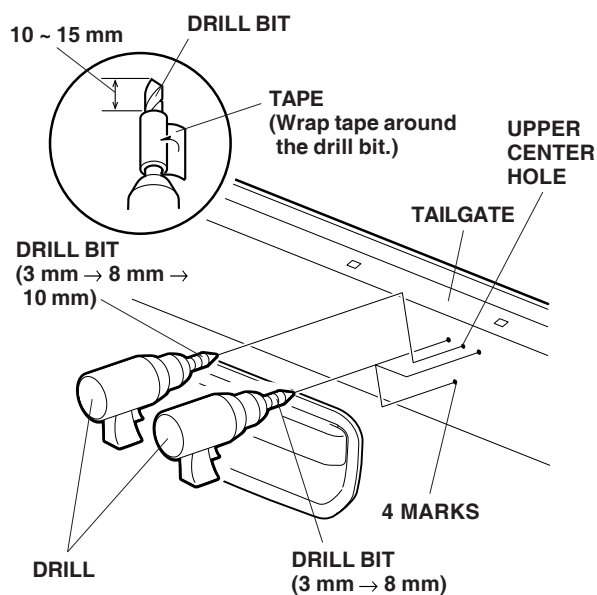

33. Install one blind nut into each 8 mm hole.

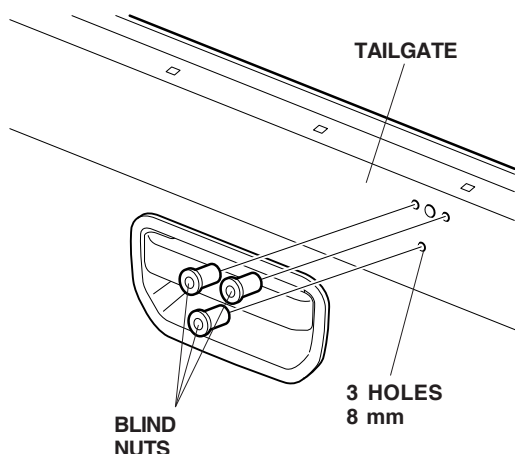

34. Remove the four screws from the rear camera. Route the rear camera harness through the rear camera subbracket, and install the rear camera subbracket to the rear camera with the four screws.

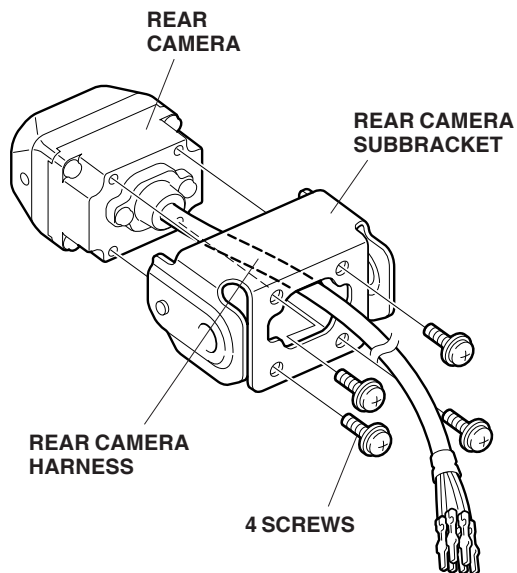

35. Attach a piece of wire to the terminals from the rear camera harness, and tape the wire to the terminals.

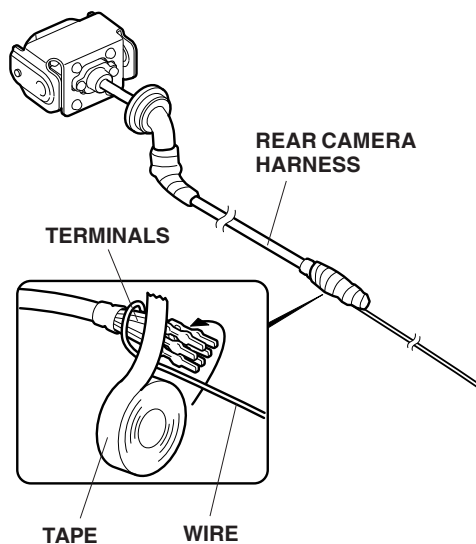

36. Route the rear camera harness through the 10 mm hole in the tailgate, and seat the grommet into the 10 mm hole.

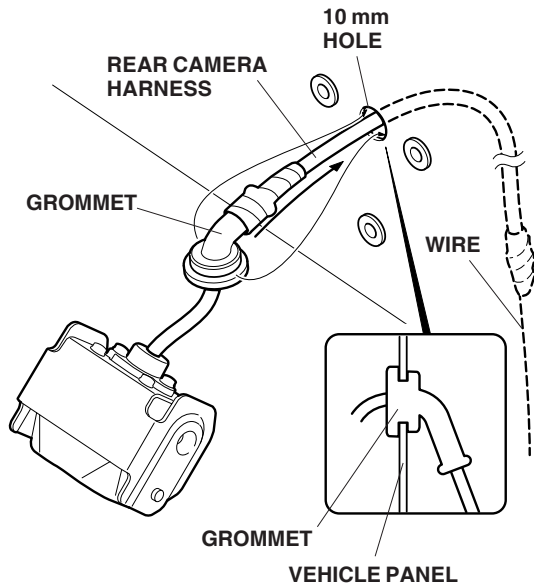

37. Install the rear camera bracket to the three blind nuts with three 4 x 12 mm washer-screws.

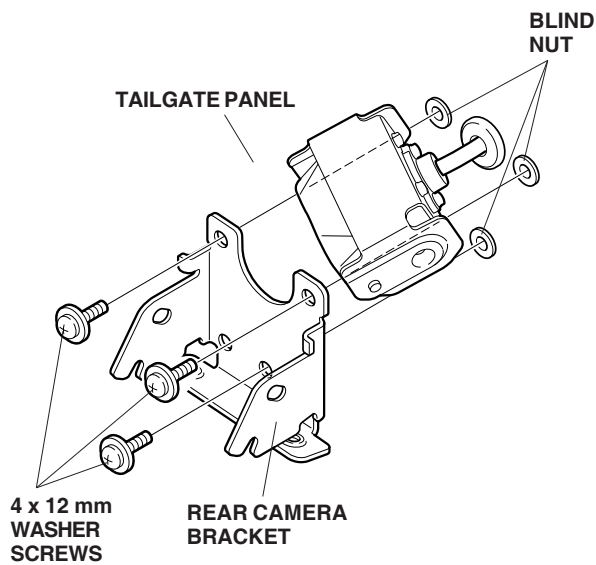

38. Align the two locating tabs on the rear camera subbracket with the rear camera bracket, and install two 4 x 6 mm washer-screws.

NOTE: Make sure the flat surface of the rear camera subbracket is facing up: otherwise, the camera view will be upside down.

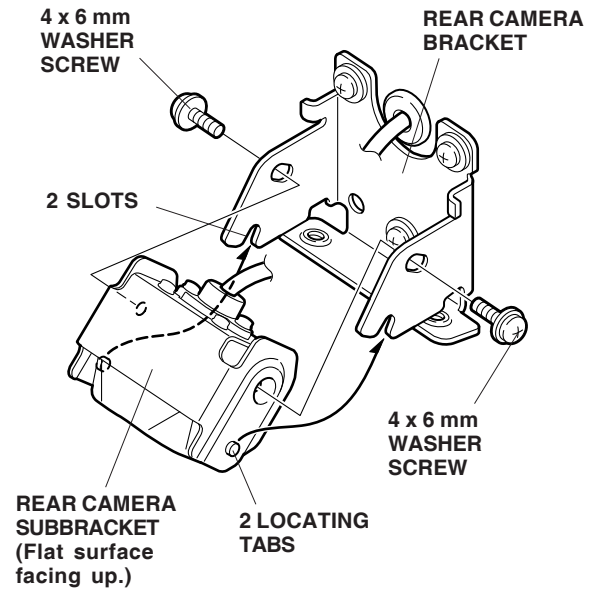

39. Install clear adhesive tapes to the tailgate:

- Open the tailgate.
- Get the clear adhesive tapes. Using scissors, cut 30 mm from the end of each adhesive tape.
- Using isopropyl alcohol on a shop towel, clean the tailgate where the adhesive tapes will attach.

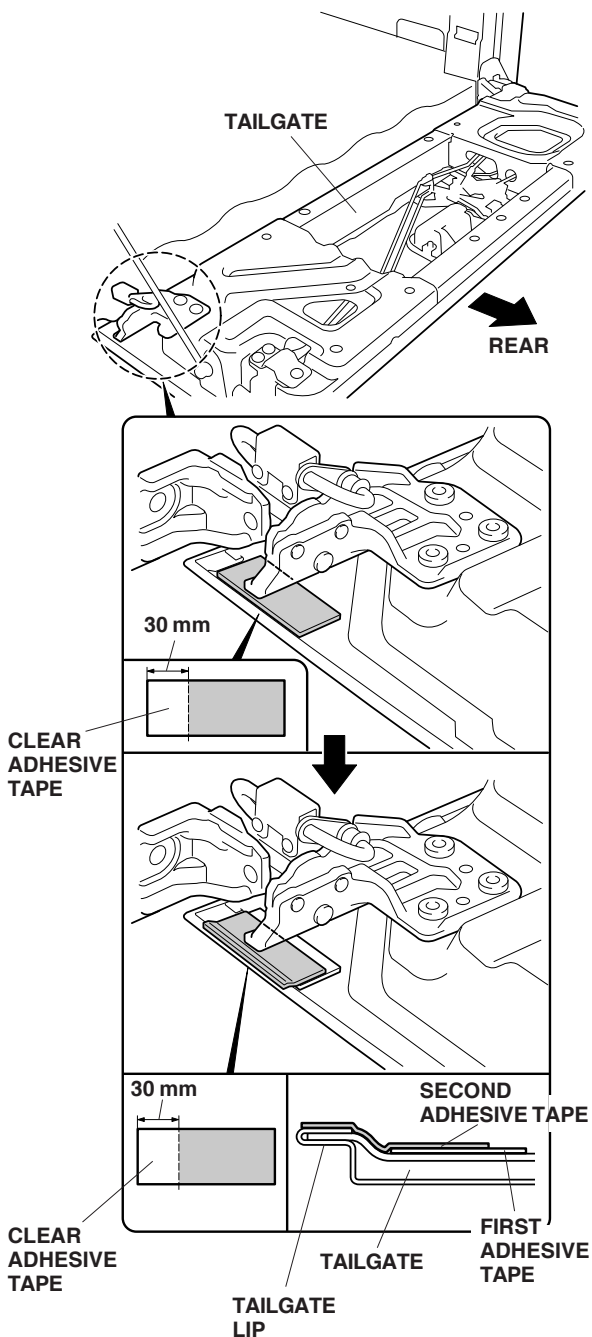

40. Route the rear camera harness along the tailgate as shown.

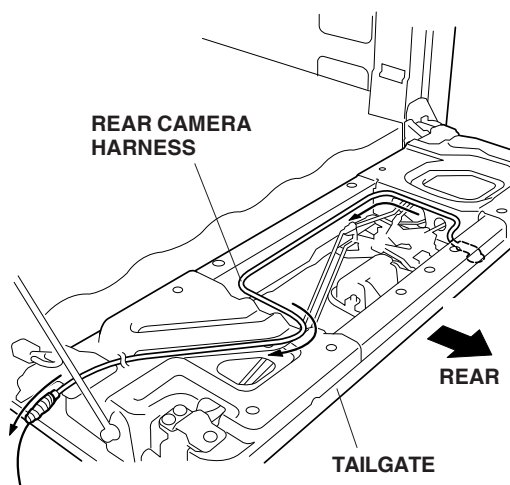

41. Remove the TORX bolt from the tailgate hinge, and attach the harness clamp bracket B to the tailgate using the TORX bolt you just removed. Do not tighten the TORX bolt at this time.

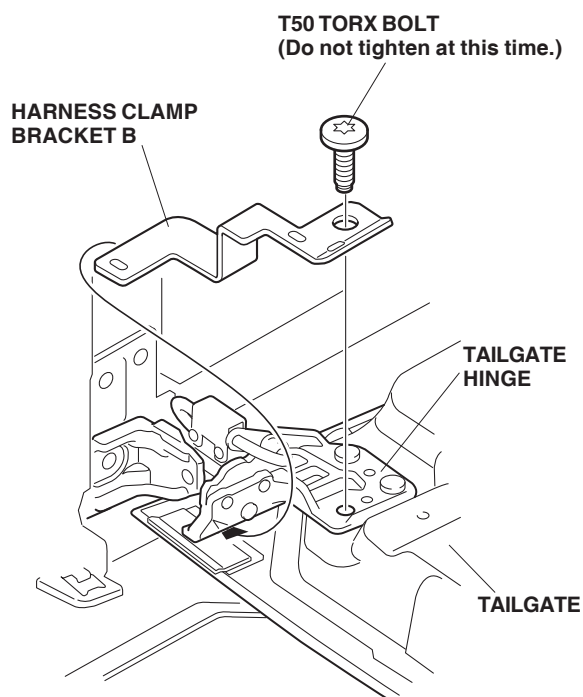

42. Secure the rear camera harness to the harness clamp bracket B with three small wire ties. Attach the wire tie over the tape attached to the harness.

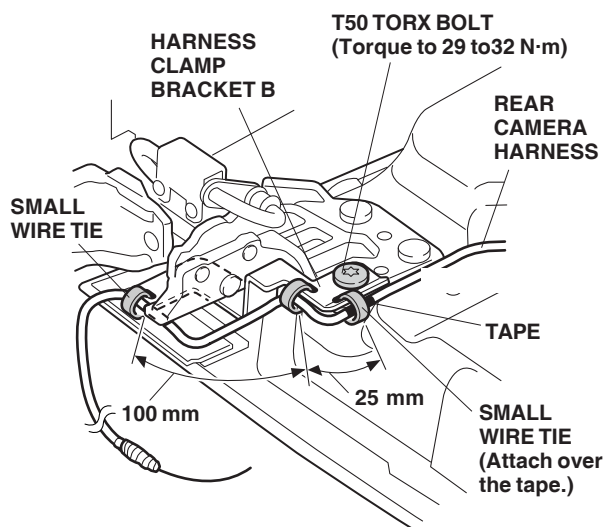

43. Torque the T50 TORX bolt to 29 to 32 N·m (21 to 23 lbs).
44. Close the tailgate. Remove the lower outboard hinge bolt, and attach harness clamp bracket A to the tailgate hinge with the TORX bolt you just removed. Do not tighten the TORX bolt at this time.

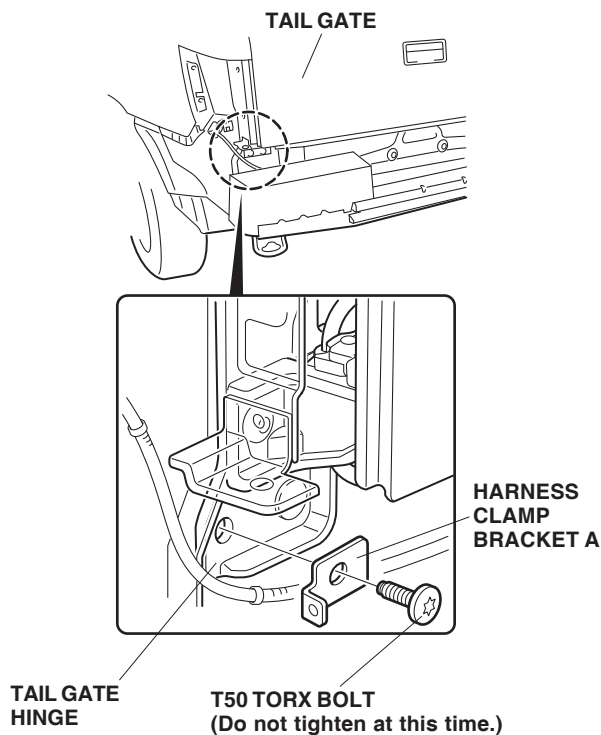

45. Pull the rear camera harness out from the inside of the tailgate, and secure the rear camera harness to the harness clamp bracket A with one small wire tie.

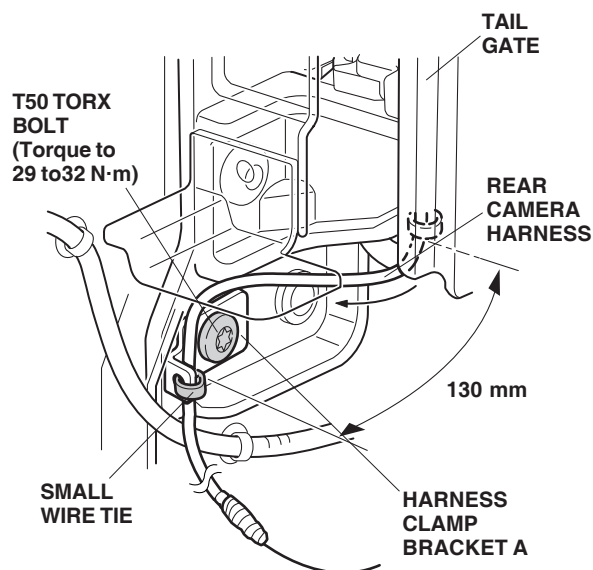

46. Torque the T50 TORX bolt to 29 to 32 N·m (21 to 23 lbs).
47. Using isopropyl alcohol on a shop towel, clean the tailgate where the cushion tapes will attach. Using scissors, cut one cushion tape in half. Secure the rear camera harness to the tailgate with two half cushion tapes and two full cushion tapes at the locations shown.

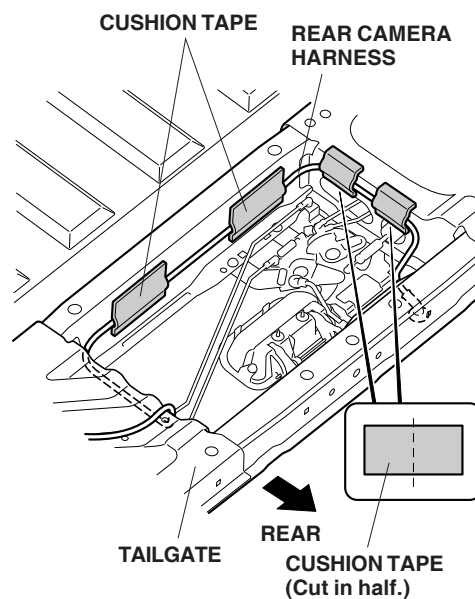

48. Secure the rear camera harness to the tailgate with five wire ties with clip.

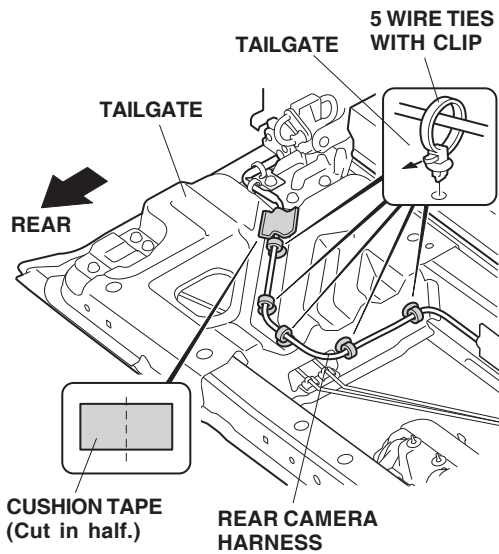

49. Using isopropyl alcohol on a shop towel, clean the tailgate where the cushion tape will attach. Using scissors, cut one cushion tape in half. Secure the rear camera harness to the tailgate with one half cushion tape.

50. Route the rear camera harness through the left side vehicle panel hole, and secure the rear camera harness to the vehicle harness with two wire ties.

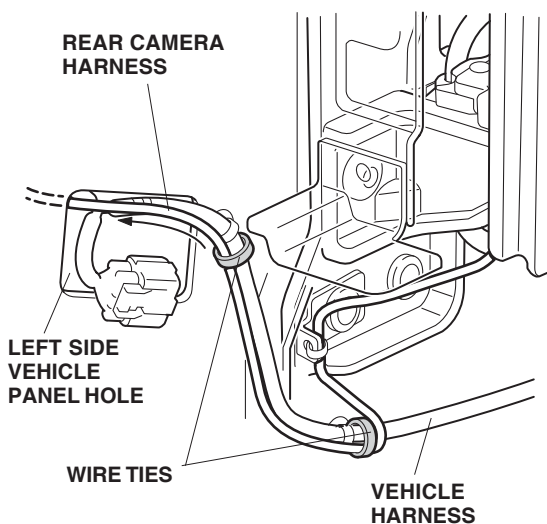

51. Route the rear camera harness out through the bed panel hole, and secure the rear camera harness to the vehicle harness with one wire tie just inside the panel hole.

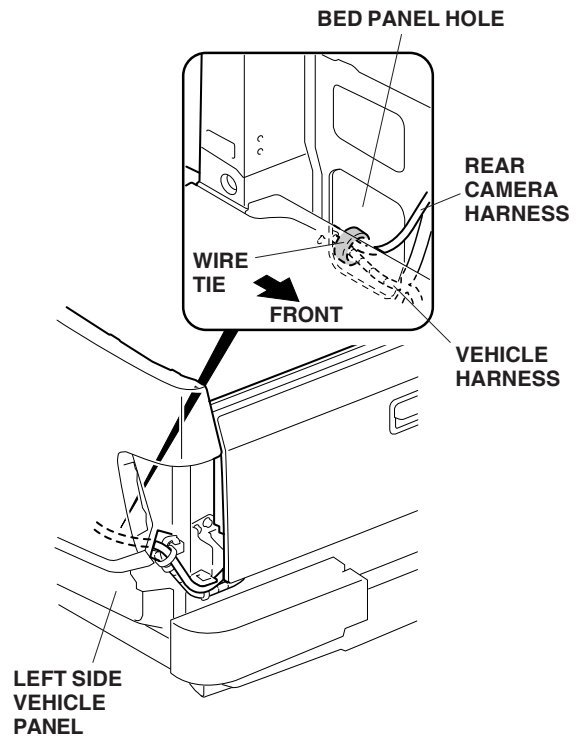

52. Route the rear camera harness along the vehicle harness towards the front of the vehicle, and secure it to the vehicle harness with six wire ties in the areas shown.

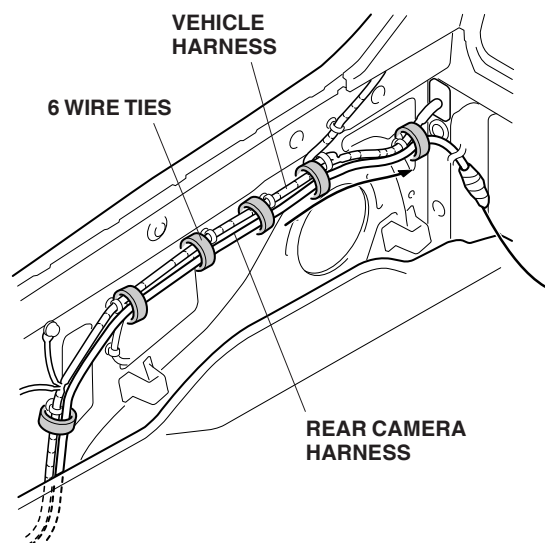

53. Remove the vehicle grommet from the left C-pillar.

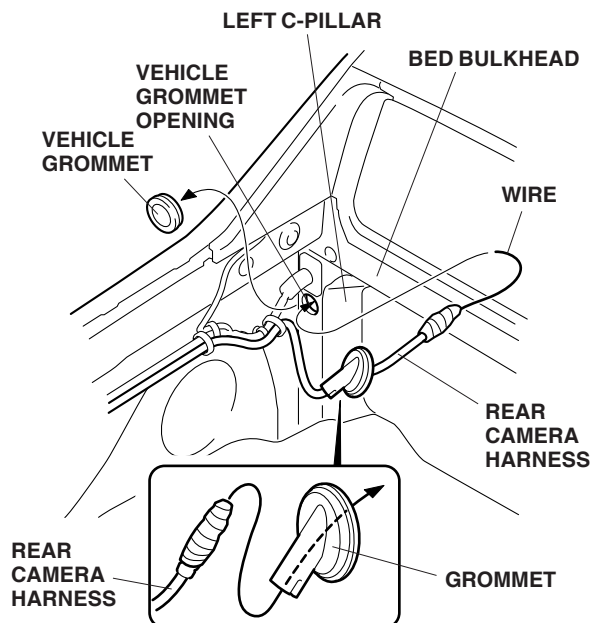

54. Insert the rear camera harness through the grommet, and route the rear camera harness through the vehicle grommet opening. Seat the grommet into the grommet hole.
55. Using electrical tape, secure the grommet to the rear camera harness, and pay attention to the angle of the grommet.

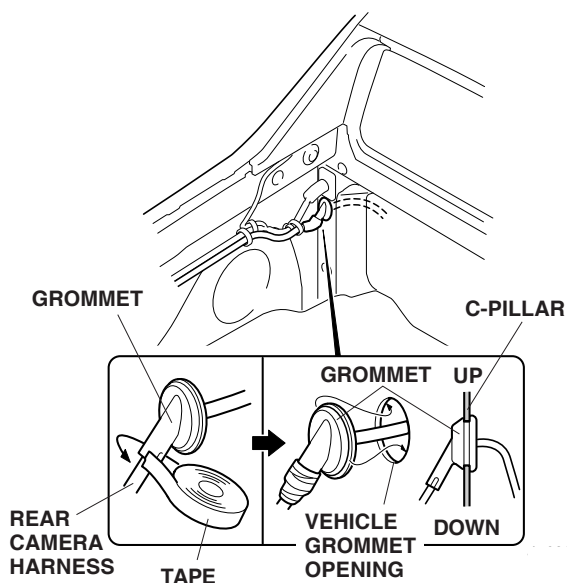

56. Inside the passenger's compartment turn down the rear panel insulator. Pull the rear camera harness out from the hole in the C-pillar, and remove the tape and wire from the rear camera harness.

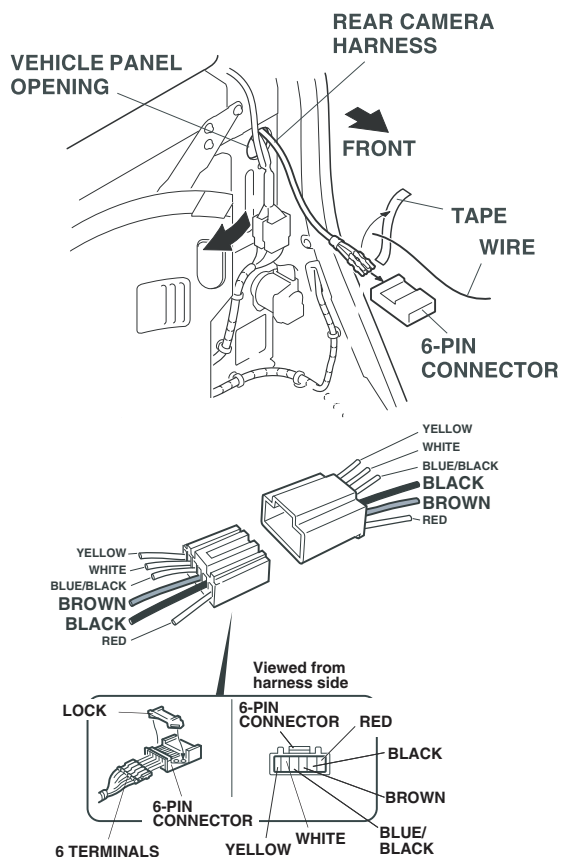

57. Remove the lock from the 6-pin connector. Plug the rear camera harness terminals into the 6-pin connector as shown. Reinstall the lock.
58. Get the rear camera subharness. Plug the rear camera subharness 6-pin connector into the rear camera harness 6-pin connector, and secure the connected 6-pin connectors to the vehicle connectors with two wire ties.

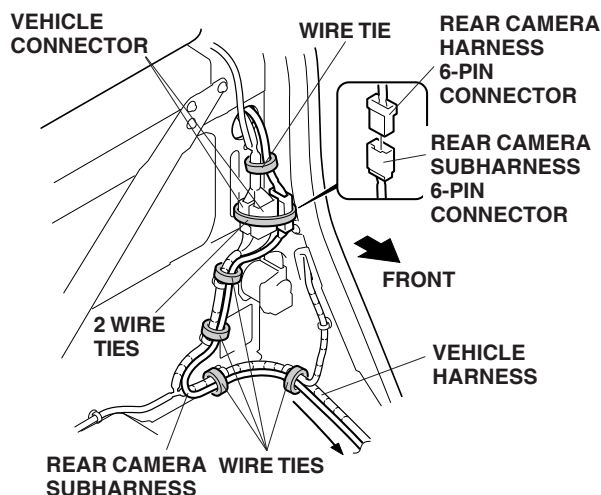

59. Route the rear camera subharness forward along the vehicle harness, and secure the subharness to the vehicle harness with five wire ties.
60. Continue routing the rear camera subharness forward along the vehicle harness, and secure the subharness to the vehicle harness with four small wire ties.

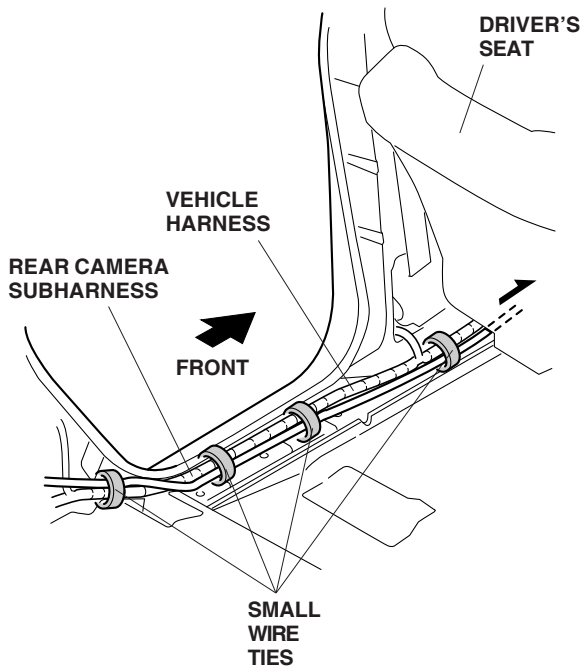

61. Route the rear camera subharness along the vehicle harness and under the floor carpet, then pull the rear camera subharness out from under the floor carpet opening under the driver's seat. Secure the rear camera subharness to the vehicle harness with two wire ties.

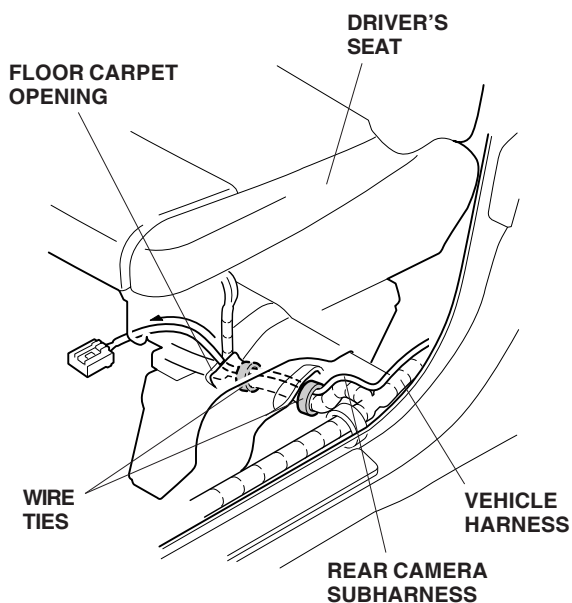

62. Plug the rear camera subharness 6-pin connector into the Navi control unit.

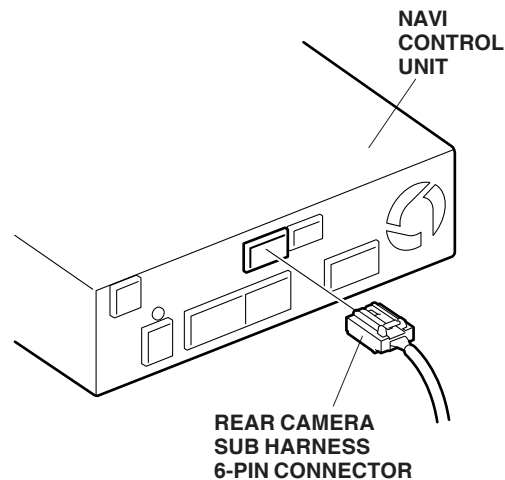

63. Slide the driver's seat back and forth to check that the rear camera subharness is not pulled too tight or is too loose.

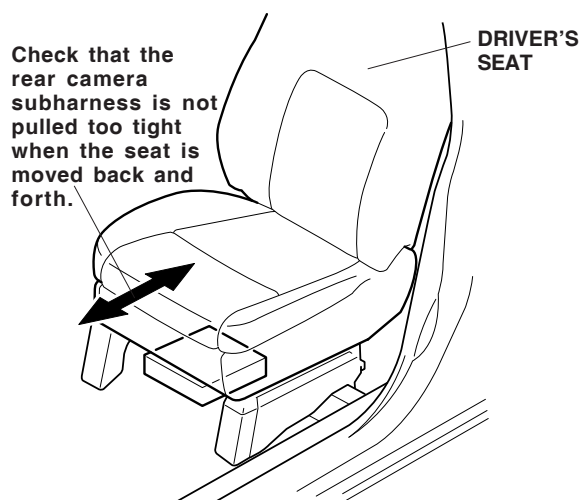

64. Reconnect the negative cable to the battery. Turn the key to the ON (II) position, and enter the Navi code.

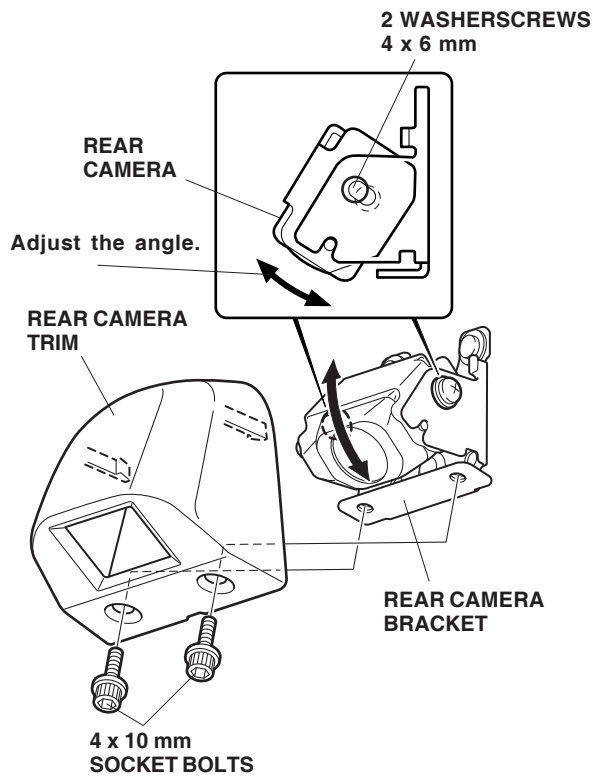

65. Move the shift knob to the “R” position.
66. Loosen the two 4 x 6 mm washer-screws. Adjust the rear camera angle up or down so that the end of the rear bumper is reflected at the lowest possible end of the navigation monitor. Tighten the two 4 x 6 mm washer-screws. Install the rear camera trim to the rear camera bracket with two 4 x 10 mm socket bolts.
67. Turn the key to the off position.

68. Measure and mark the rear bumper at the location shown.

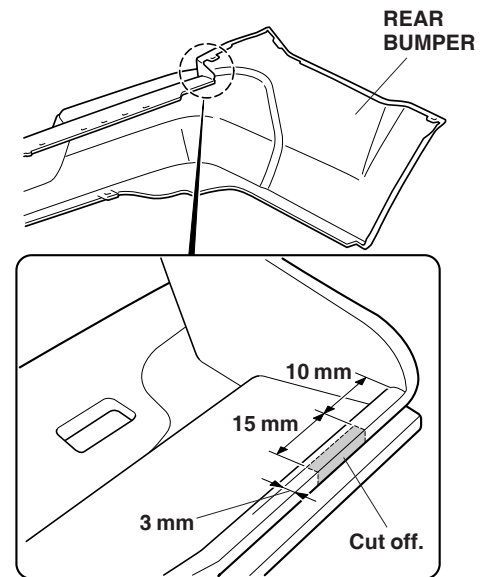

69. Using a utility knife, cut and remove measured piece from the rear bumper. Remove any burrs from the cut area with a file.
70. Reinstall the rear bumper.
71. Check that all wire harnesses are routed properly and all connectors are plugged in.
72. Enter the customer’s radio anti-theft code, and reset the radio station presets.
73. Set the clock.
74. Check the operation of the rear camera according to the owner’s manual provided.
75. Put the rear camera Owner’s Manual in the glove box with the vehicle owner’s manual.
76. Reinstall all removed parts.

NOTE: To reinstall the bed rail trim:

- With one hand on each end of the bed rail trim, hook the seven clips under the bed liner lip.

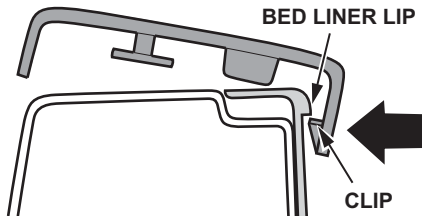

- Roll the trim toward the outside of the bed rail, so the trim now lies flat on top of it and all six lock tabs engage the slots in the bed rail.

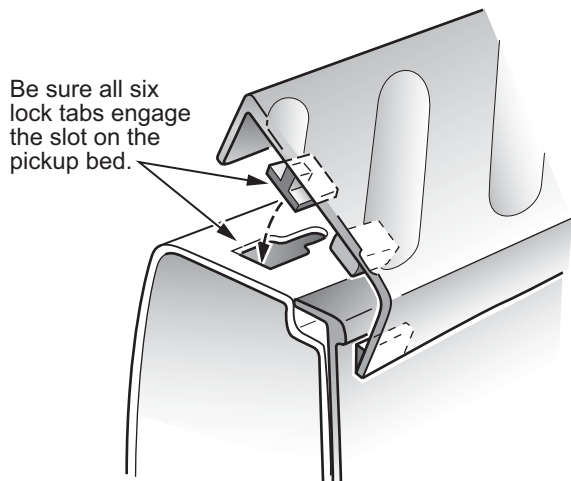

- With one hand on each end of the trim, push down and slide it toward the cab until you feel it stop. This locks the tabs in place.
- Starting at the front end, press up on the edge of the trim with your thumb to make sure it's secure. Then, working your way down the trim, repeat this to ensure the other lock tabs and the clips are secure.
- Reinstall the mounting screw and the trim cap.

NOTE: Whenever the battery is disconnected, the driver's window AUTO function is disabled.

77. Start the engine. Push down fully on the driver's window switch until the window is fully open.
78. Pull up fully on the driver's window switch to close the window completely, then hold the switch for 2 second or more.
79. Test the window AUTO function.