



INSTALLATION INSTRUCTIONS

Accessory
FOG LIGHTS
P/N 08V31-SNA-100B

Application
2008 CIVIC
HYBRID

Publications No.
All 37966-40032

Issue Date
OCT 2008

PARTS LIST

Right fog light

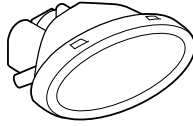

Left fog light



Right bracket A

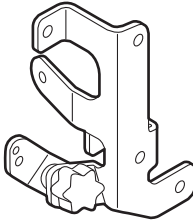

Left bracket A

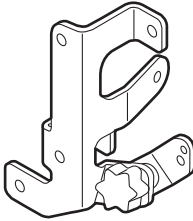

Right bracket B

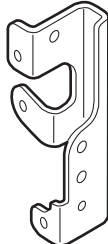

Left bracket B

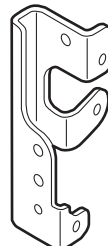

Switch harness

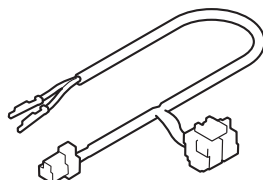

Fog light harness

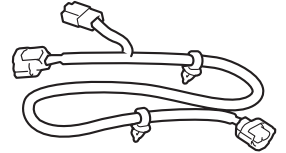

Subharness

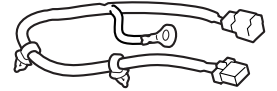

Switch

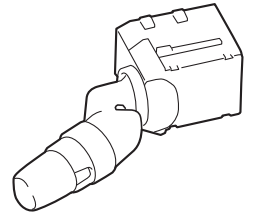

Right trim

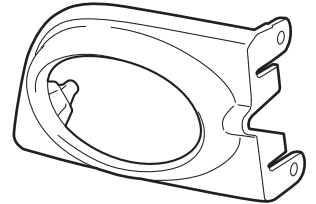

Left trim

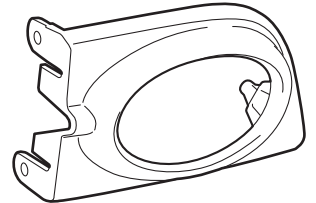

4 Large stepped screws



5 Wire ties

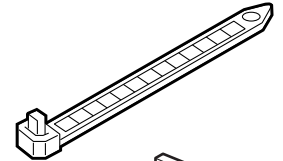

Clip



4 Small stepped screws



2 Washer screws, 4 x 8 mm



10 Self-tapping screws, 5 x 16 mm



Fuse (20A)

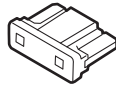

Relay

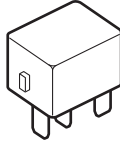

4 Wire ties with clips A

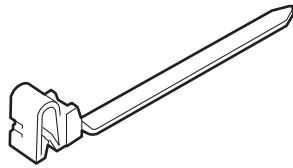

Wire tie with clip B

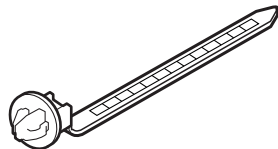

Ground bolt

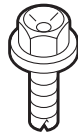

TOOLS AND SUPPLIES REQUIRED

- Phillips screwdriver
- Flat-tip screwdriver
- Ratchet
- 10 mm Sockets
- Drill
- 3 mm Drill bit
- 20 mm Hole saw
- Blanket
- Pushpin
- Utility knife
- Gloves
- Hacksaw blade
- Masking tape
- 5 mm Hex wrench

Illustration of Fog Lights installed on the vehicle

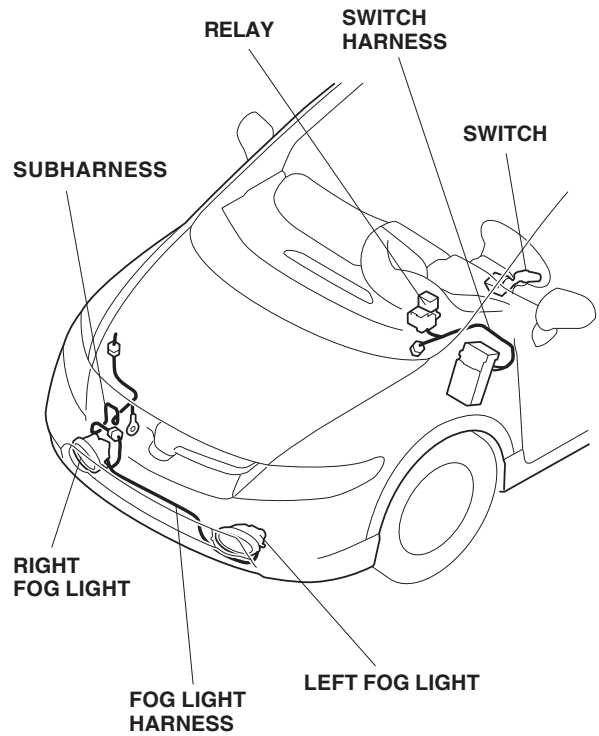

INSTALLATION

Customer Information: The information in this installation instruction is intended for use only by skilled technicians who have the proper tools, equipment, and training to correctly and safely add equipment to your vehicle. These procedures should not be attempted by "do-it-yourselfers."

1. Make sure you have the anti-theft code for the radio, then write down the frequencies for the preset buttons.
2. Disconnect the negative cable from the battery.
3. Remove the front bulkhead cover (two expansion clips, three clips and move the right and left fender trims inward).

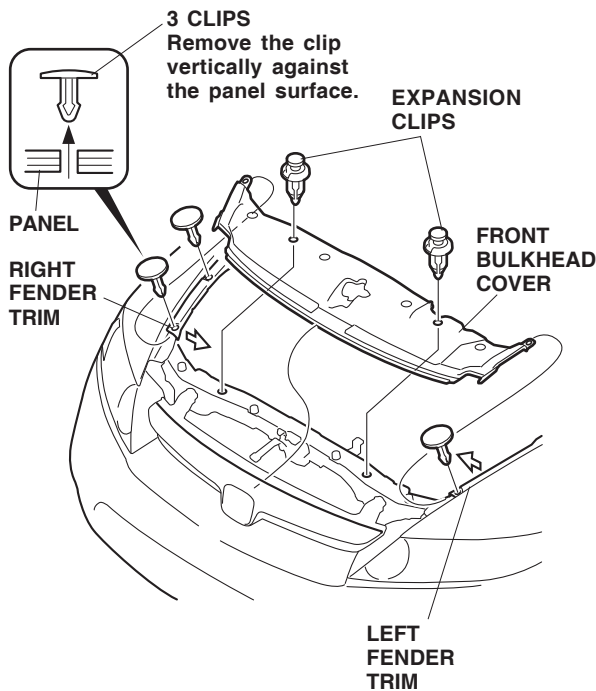

4. With the help of an assistant, remove the front bumper (four long clips, four center clips, two socket bolts, and two self-tapping screws). To prevent damage, set the front bumper on a blanket.

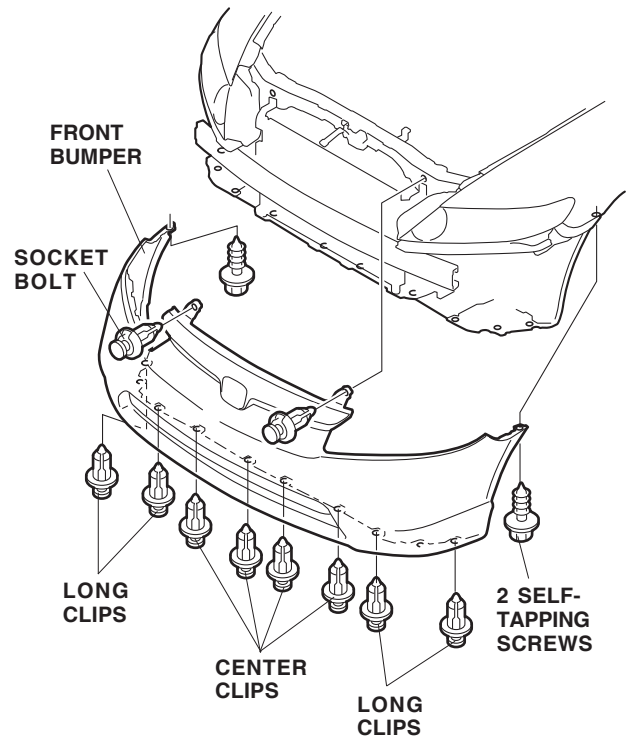

5. Apply masking tape to the front bumper (left side) in the area shown.

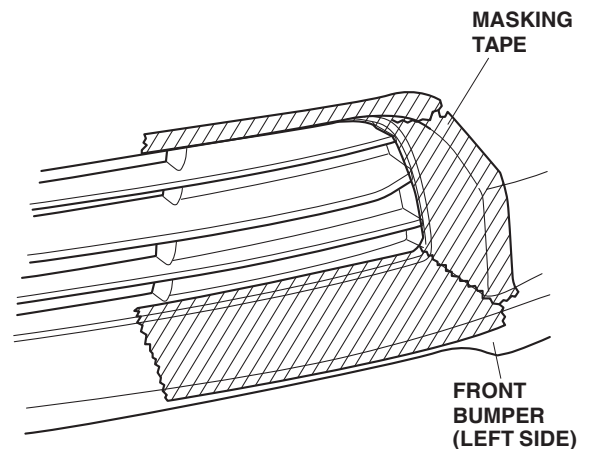

- On the inside of the bumper, locate and remove the bumper cover (six self-tapping screws).

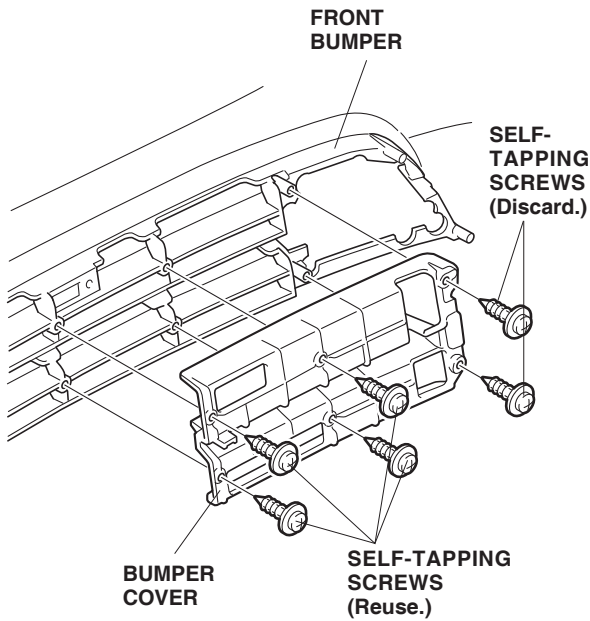

- On the inside of the front bumper, locate the eight marks on the driver's side of the bumper. Using a pushpin, pierce the front bumper at each of the eight marks.

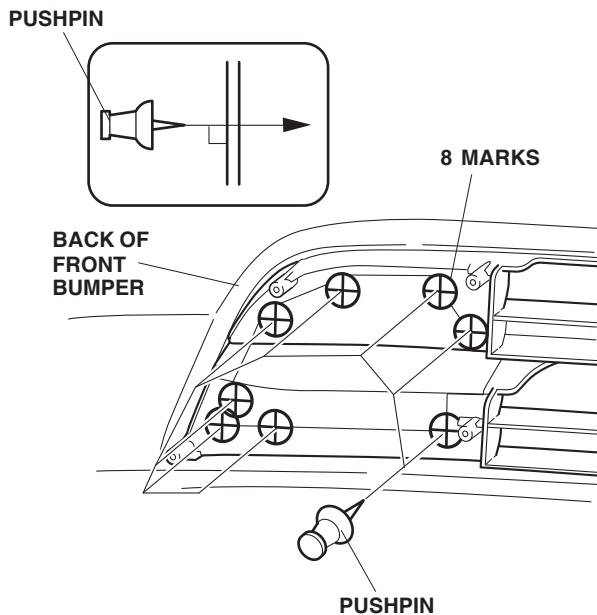

- If the mark at the illustrated position is not visible, measure the dimensions and make a mark on the front bumper with a pushpin as shown in the illustration.

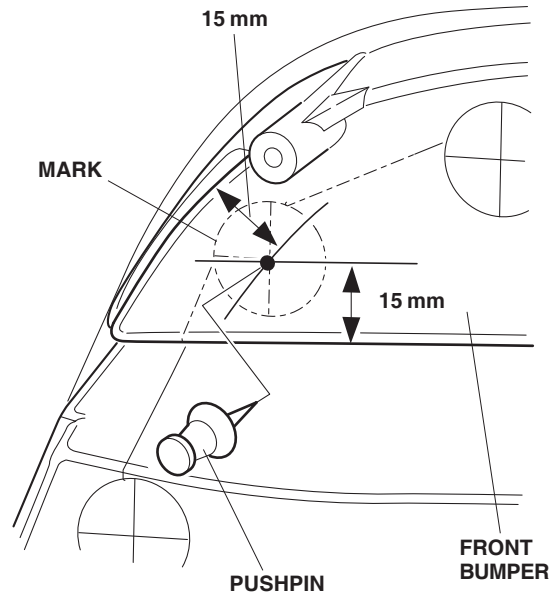

- While wearing eye protection, drill a 20 mm hole through each of the eight marks on the front bumper with a 20 mm holesaw.

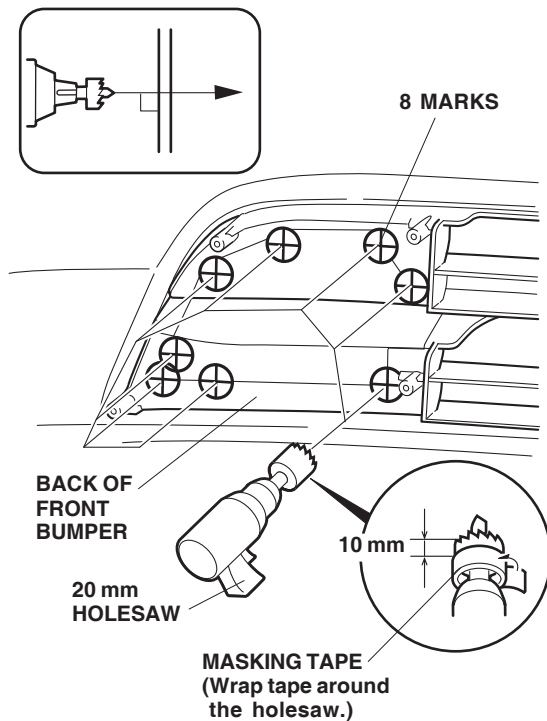

- Using a hacksaw blade, cut out the marked area on the front bumper.
 - Take care not to damage the front bumper.
 - After cutting out the marked area, remove any burrs from the edges of the hole.

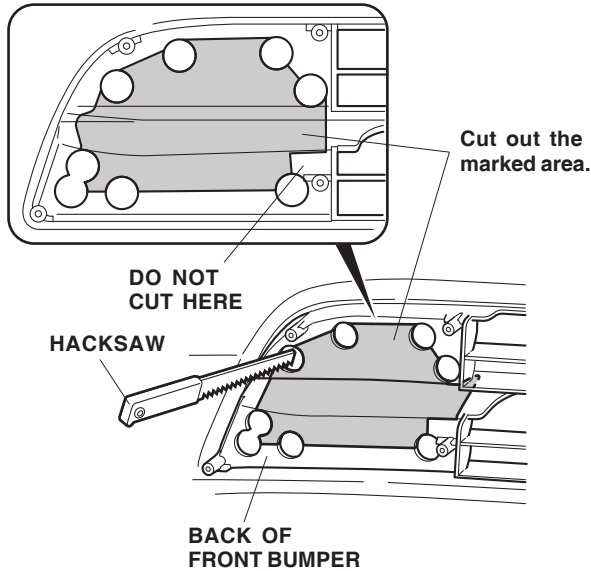

- Using a utility knife, cut out the two pieces of bumper in the two areas shown.
 - If there are pins on the front bumper, cut them off as shown.

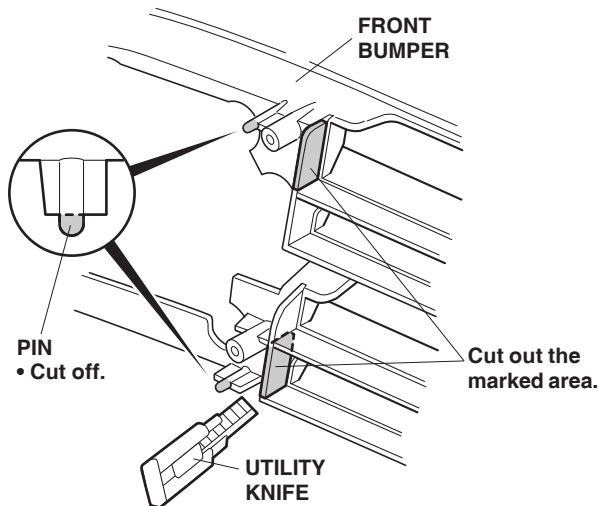

- Repeat steps 5 thru 11 to mark and cut out the right side of the bumper.

- Position the left bracket A and left bracket B on the left fog light, and install the two small stepped screws and one 4 x 8 mm washer screw. Tighten the screws securely. Install the brackets on the right fog light the same way. Before installing bracket A and bracket B, check the identification marks: The brackets marked "L" go on the left side; the brackets marked "R" go on the right side.

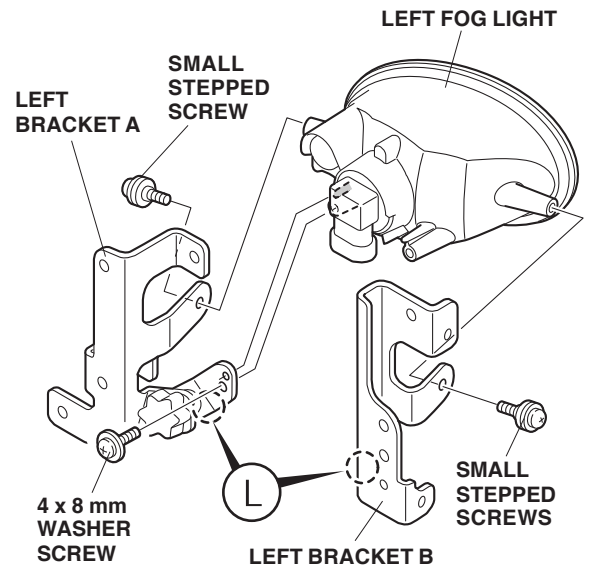

- Inside the front bumper, slide the fog light into the cutout you made, and secure it with four 5 x 16 mm self-tapping screws.

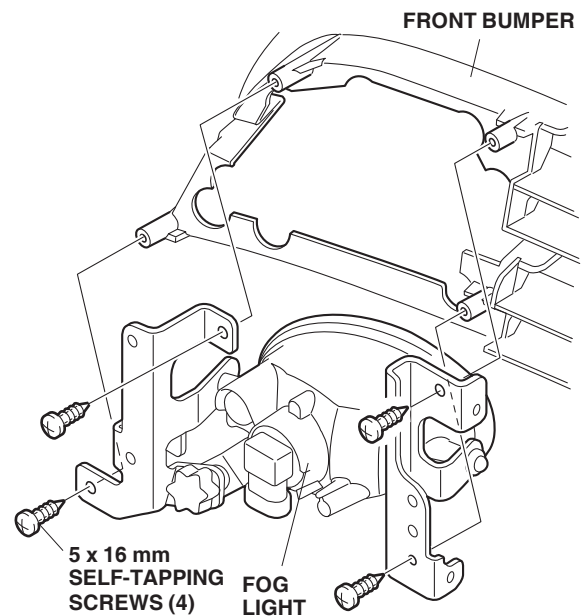

- On the right side of the vehicle, attach the right fog light bracket B, installed on the right fog light, to the bumper cover. Then, install the bumper cover/right fog light bracket B assembly on the front bumper using four of the six self-tapping screws and four 5 x 16 mm self-tapping screws.

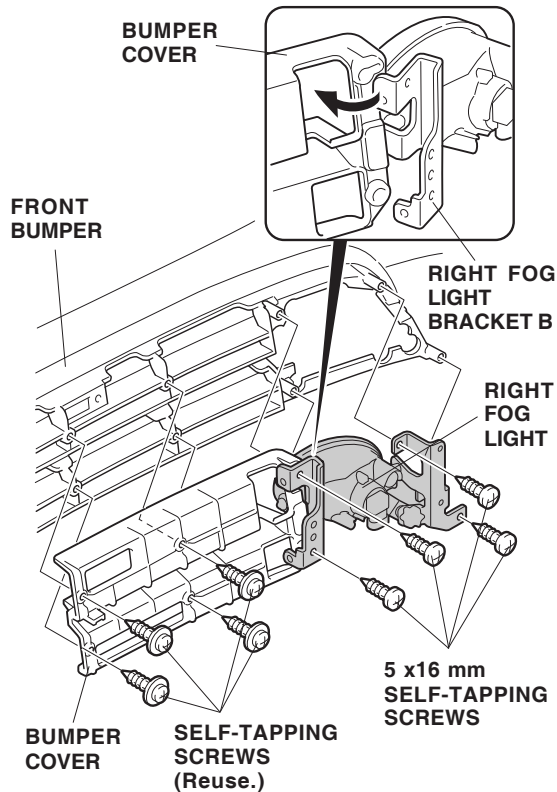

- Position the left trim on the bumper and install it with the two large stepped screws and one 5 x 16 mm self-tapping screw.

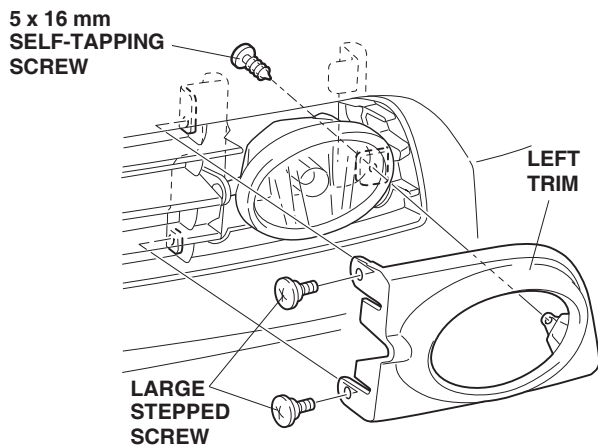

- Install the right trim the same way.

- Connect the fog light harness 2-pin connector to the left fog light and route the fog light harness along the inner side of the front bumper. Connect the 2-pin connector to the right fog light.

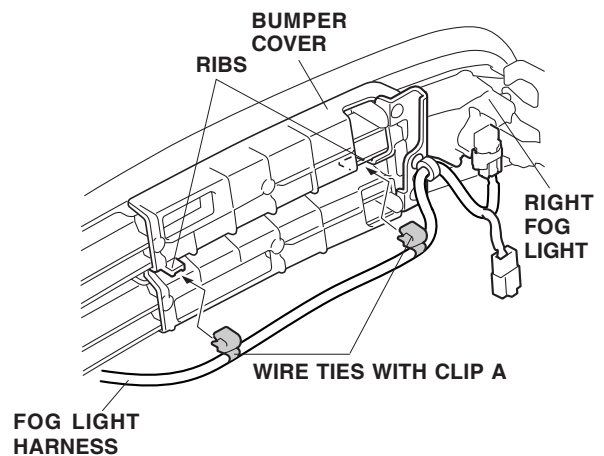
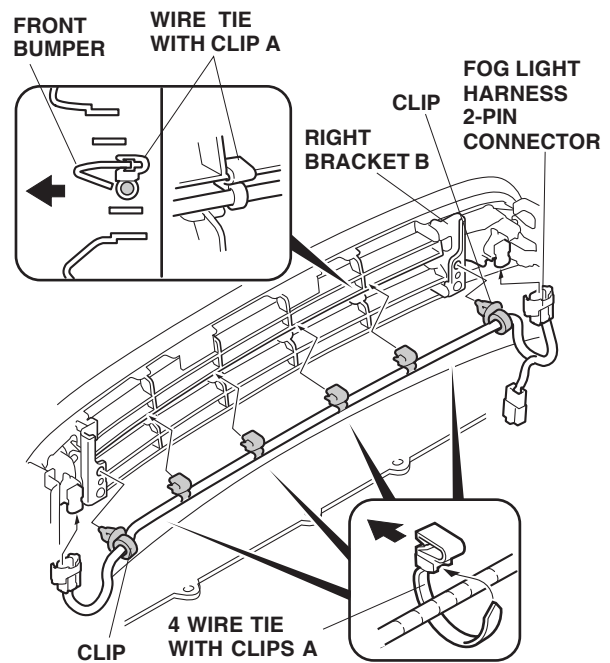

- Secure the two clips on the fog light harness to the left bracket B and right bracket B.
- Install the four wire ties with clips A on the fog light harness. Align the wire ties next to the vertical ribs. Secure the fog light harness to the front bumper by inserting the two left wire ties with clips A into the front bumper opening, and the two right wire ties with clips A to the ribs of the bumper cover.

21. Slide the clip onto the fog light harness 2-pin connector and secure it to the fog light bracket A.

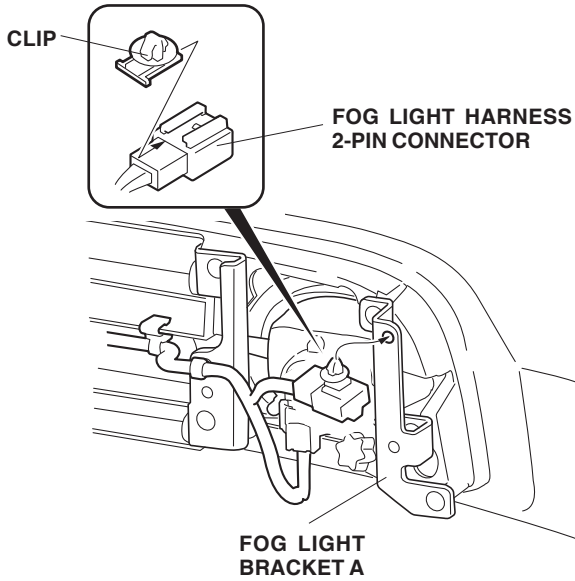

22. Locate the 1-pin connector blue-taped to the vehicle harness and remove the blue tape to free the 1-pin connector. Plug the 1-pin connector you just freed into the 1-pin connector of the subharness.

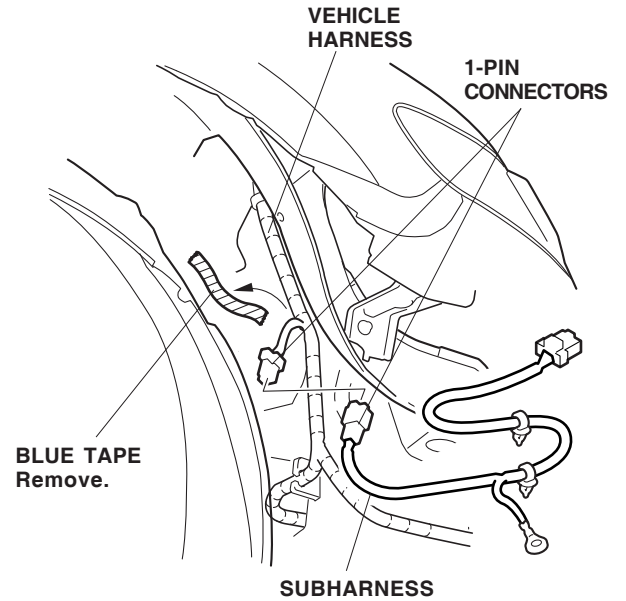

23. Route the subharness between the washer reservoir tank and vehicle panel as shown.

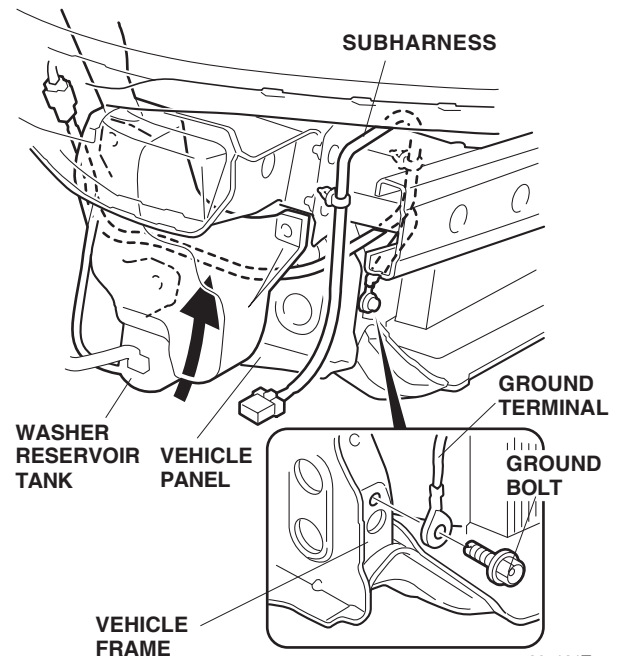

24. Secure the subharness ground terminal to the vehicle frame using the ground bolt supplied.

25. Secure the two subharness clips to the vehicle frame, and secure the subharness to the vehicle harness with two wire ties.

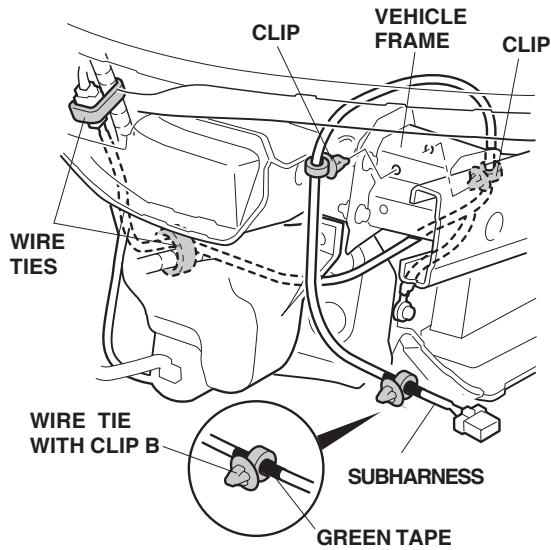

26. Install a wire tie with clip B to the subharness in the position marked with the green tape.
27. Connect the subharness 2-pin connector to the fog light harness 2-pin connector. Secure the wire tie with clip B at the green tape to the right bracket A, then reinstall the front bumper.

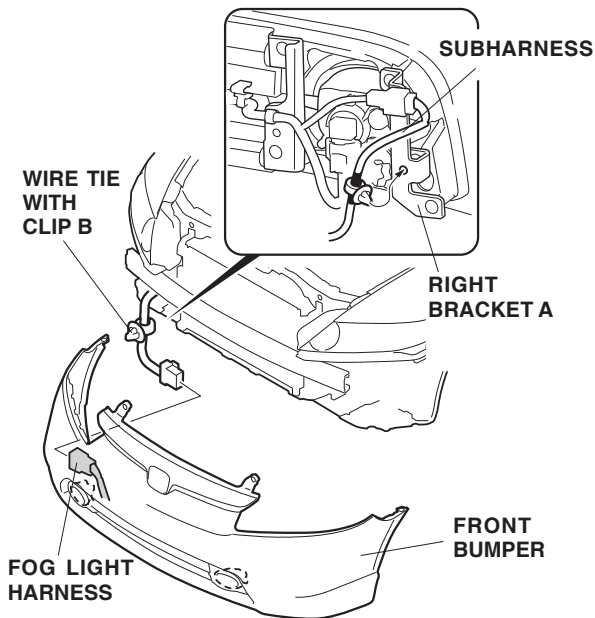

28. If equipped, remove the driver's dashboard under cover by turning the knob counterclockwise, and releasing two clips and pin. Take care not to damage the clips.

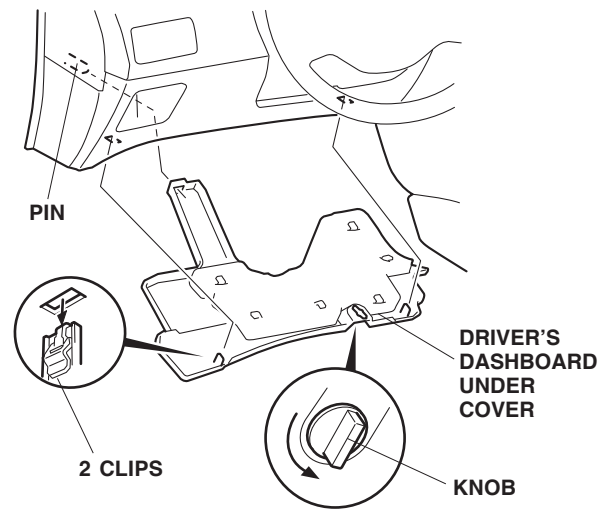

29. Remove the driver's dashboard lower cover. Release the eight retaining clips. Take care not to damage the clips.

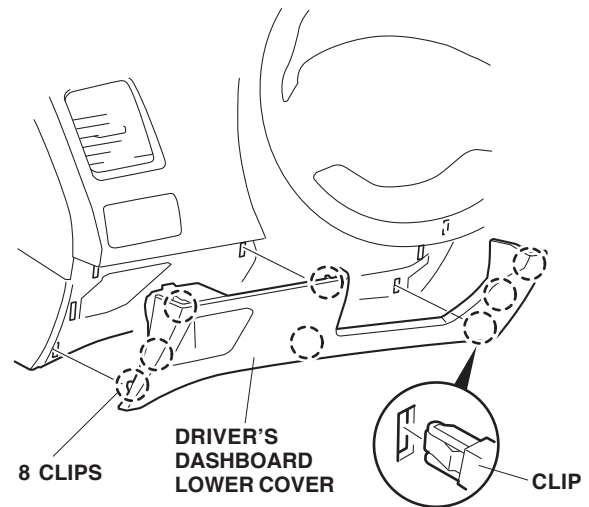

- Lower the tilt lever. Insert a flat-tip screwdriver along the guide on the column lower cover and release the retaining tabs from the upper column cover.

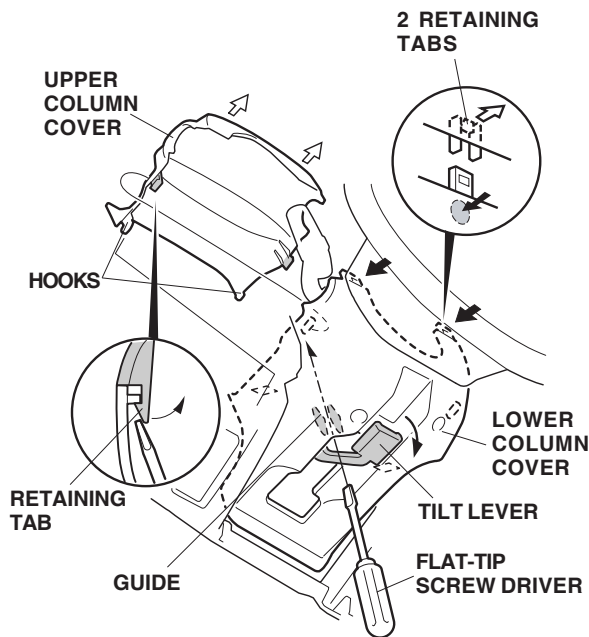

- Separate the upper column cover from the lower column cover (two retaining tabs).
- Remove the upper column cover (two hooks).
- Remove the lower column cover (two self-tapping screws and one screw).

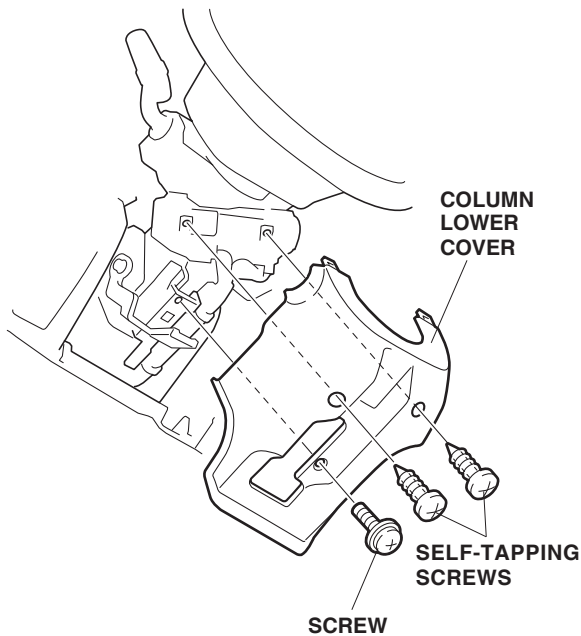

- Remove the green 42-pin connector, white 34-pin connector, and the blue 21-pin connector from the fuse box by pushing the retaining tab and raising the lock on each respective connector.

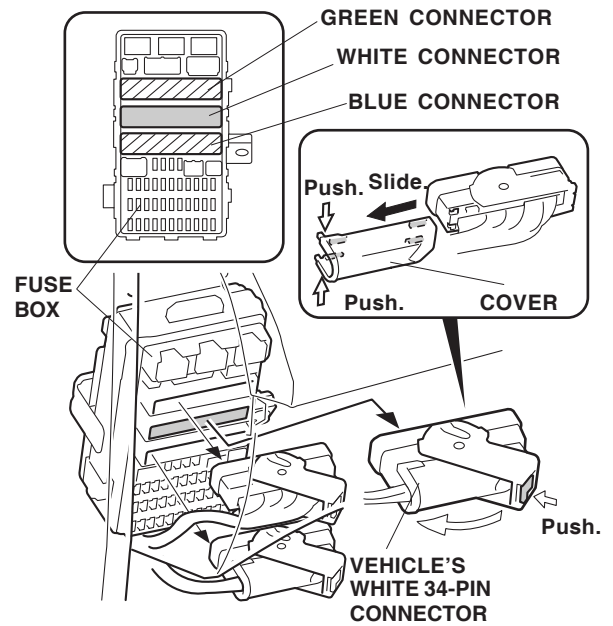

- Close the lock on the vehicle's white 34-pin connector and remove the cover by sliding it. Insert the switch harness white/red terminal and the blue terminal into the vehicle white 34-pin connector.

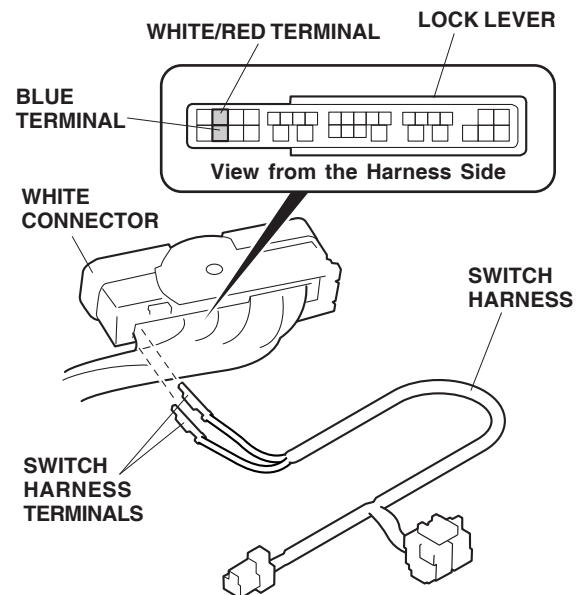

- Reinstall the cover on the 34-pin connector, then reinstall the vehicle connectors in the fuse box.

37. Route the switch harness above the vehicle knee bolster.

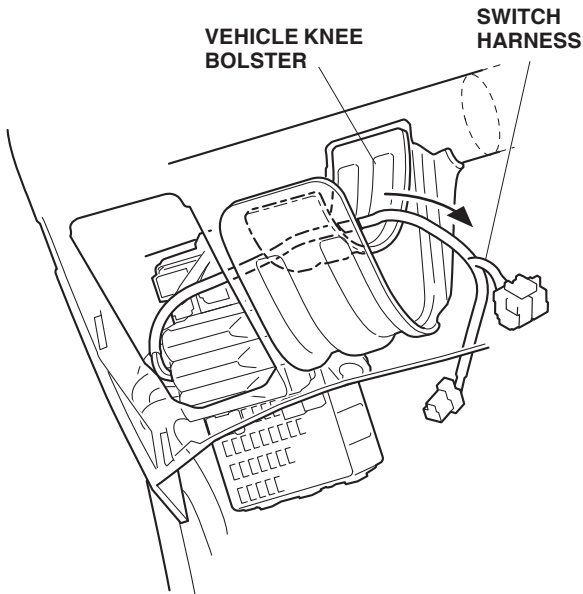

5307180T

38. Plug the relay into the switch harness relay block, then slide the relay block onto the vehicle bracket.

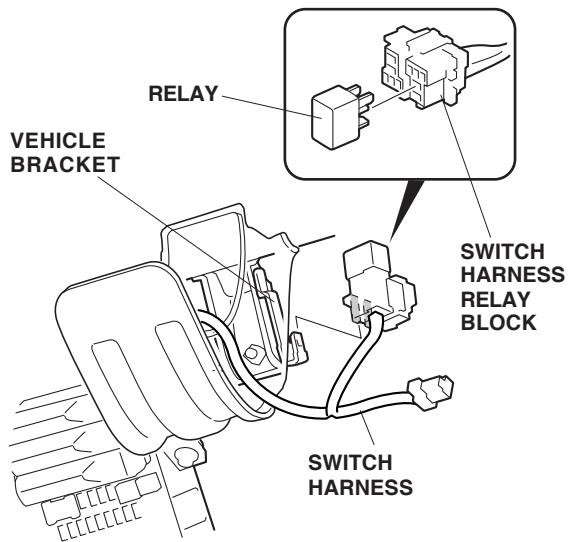

39. Locate the 1-pin connector blue-taped to the vehicle harness. Plug the 1-pin connector into the 1-pin connector of the switch harness.

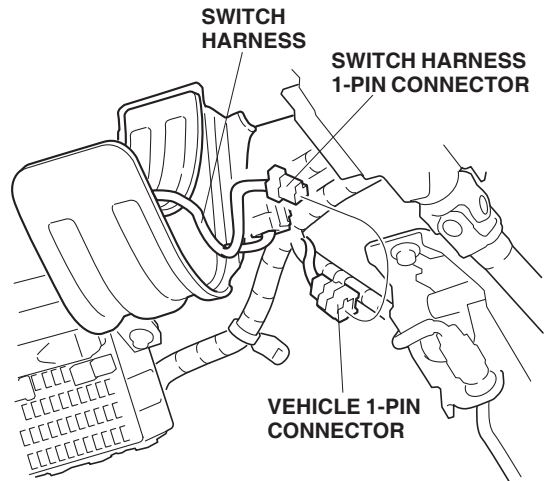

40. Secure the switch harness to the vehicle harness and vehicle knee bolster with three wire ties in the areas shown.

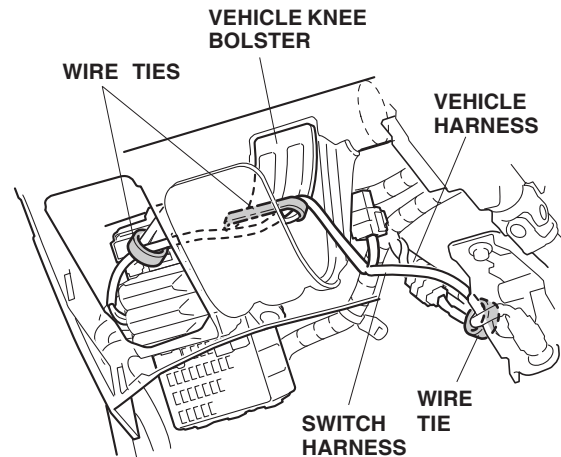

41. Lower the tilt lever and pull the steering wheel toward you.
42. Turn the steering wheel 90° counterclockwise.

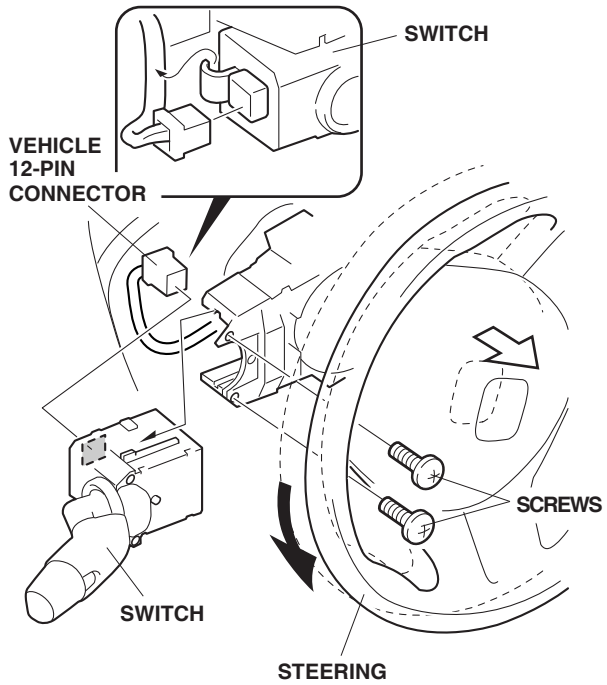

43. Remove the vehicle 12-pin connector from the switch. Remove the two screws from the switch and remove the switch.

44. Install the new switch with the original screws. Then plug the vehicle 12-pin connector into the new switch.
 - Do not install the switch while holding the lever.

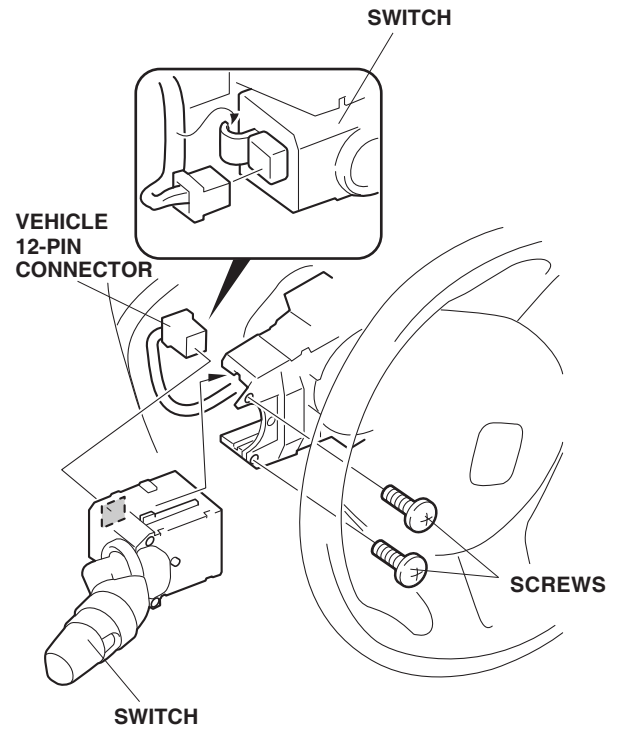

45. Install the 20A fuse into the fuse box in the location shown.

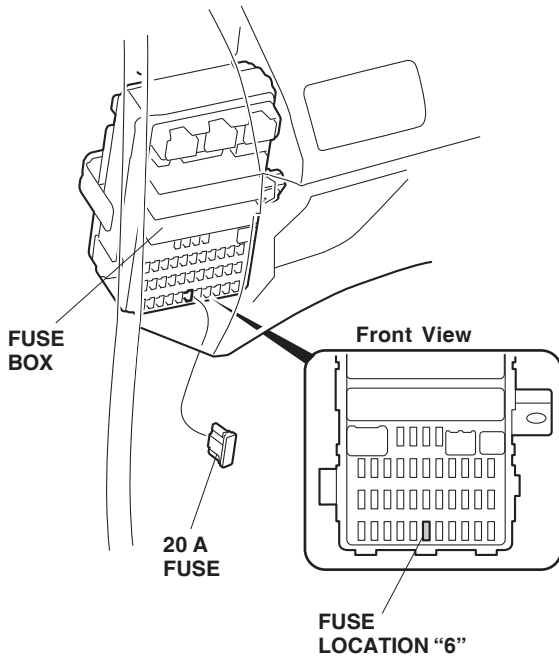

46. Check that all wire harnesses are routed properly and all connectors are plugged in.
47. Reinstall all removed parts. Do not reinstall the outboard bumper bolt at this time. Check that all clips and fasteners are installed securely.
48. Reconnect the negative cable to the battery.

USE AND CARE

How to Operate Fog Lights

- Turn the light switch to the “**D**” position (headlights on low beam).
- Turn on the fog light switch (indicator is on).

NOTE: The fog light lenses can cloud when the outside temperature is cold; this is normal and should go away in warm weather.

- If the fog lights don't come on, check the fuse and all the connectors, including the ground cable.

Fog Light Aiming Adjustment

49. Adjust the fog lights:
- Pull down the inner fender and under cover.
 - Adjust the aiming according to local laws and regulations.
 - To adjust, turn the aiming adjustment knob in or out until the correct aiming is obtained.

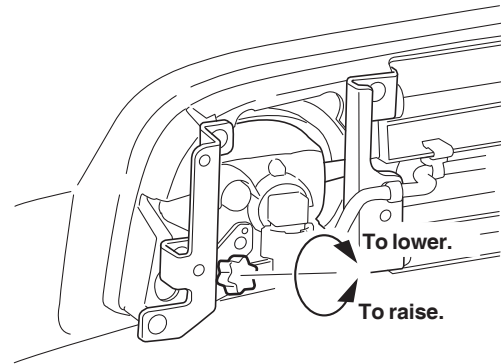

50. Reset the clock, and reset the radio station presets.
51. Reinstall the four outboard bumper bolts.
52. If the IMA battery level gauge (BAT) displays zero segments, start the engine, and hold it between 3,500 and 4,000 rpm (in Park or Neutral) until the IMA level gauge (BAT) displays at least three segments.
53. Because the battery was disconnected, you need to enter the Honda multi-matic feedback signal as described in the service manual.

NOTE: When the battery is disconnected, the driver's window AUTO function is disabled.

54. Start the engine. Push down on the driver's window switch until the window is fully open.
55. Pull up on the driver's window switch to close the window completely, then hold the switch for 2 seconds or more.
56. Lower and raise the driver's window to check operation of the driver's window AUTO function.

BULB REPLACEMENT

1. Remove the two long clips and three clips from the bottom of the front bumper, and pull down the inner fender and under cover.

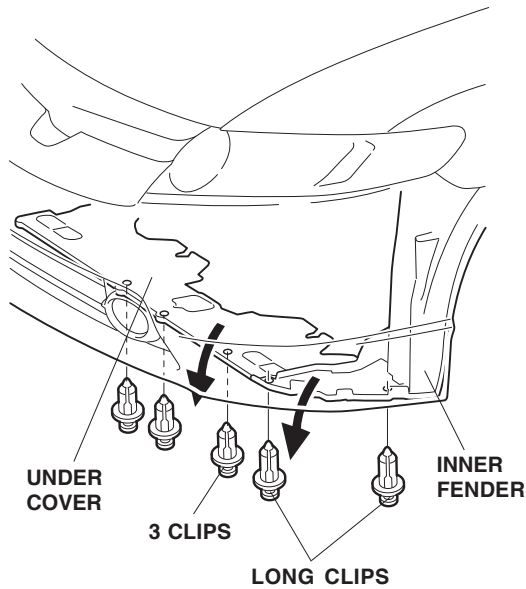

2. Unplug the connector from the fog light.
3. Remove the bulb.

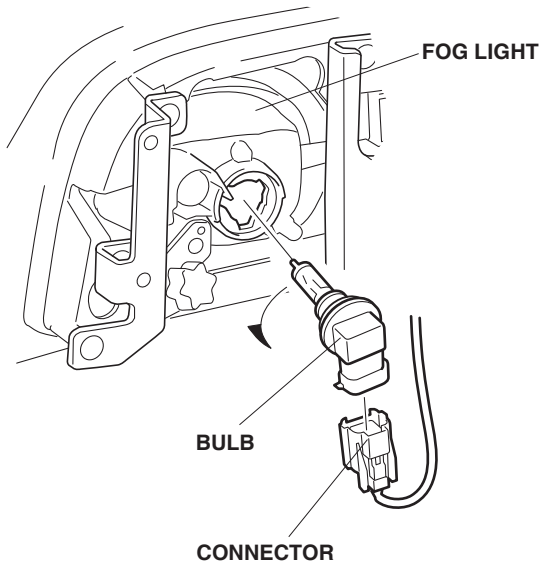

4. Install the new bulb and socket into the fog light.
 - Use only a genuine Honda halogen light bulb of specified wattage.

Rating: 12V 55W H11 Halogen Light Bulb,
P/N 33165-S5A-003

- Do not touch the bulb. Oily or greasy substances on the bulb can shorten its service life due to the heat produced when the bulb is turned on. If the bulb is accidentally touched, wipe it clean with a soft cloth that has been dampened with a denatured alcohol or a mild detergent solution.
- Align the tab on the fog light with the cutout in the bulb when installing the new bulb. If not aligned, the fog light may annoy oncoming drivers.

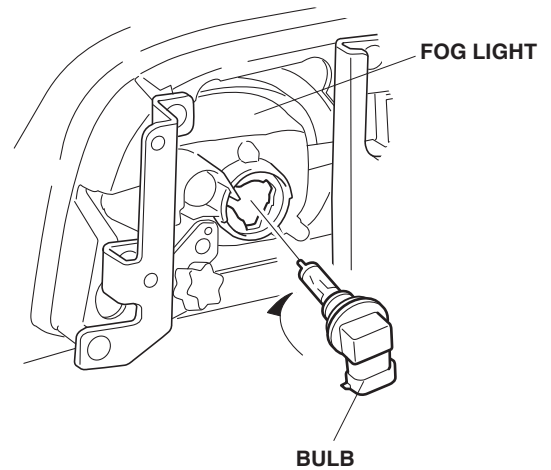

5. Reinstall the removed parts in the reverse order of removal.
 - Check that the wire harnesses are not pinched.
6. Check the operation of the fog lights; adjust the aiming if necessary.

CIRCUIT DIAGRAM

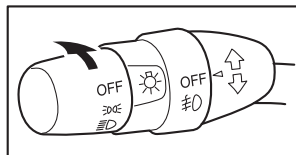
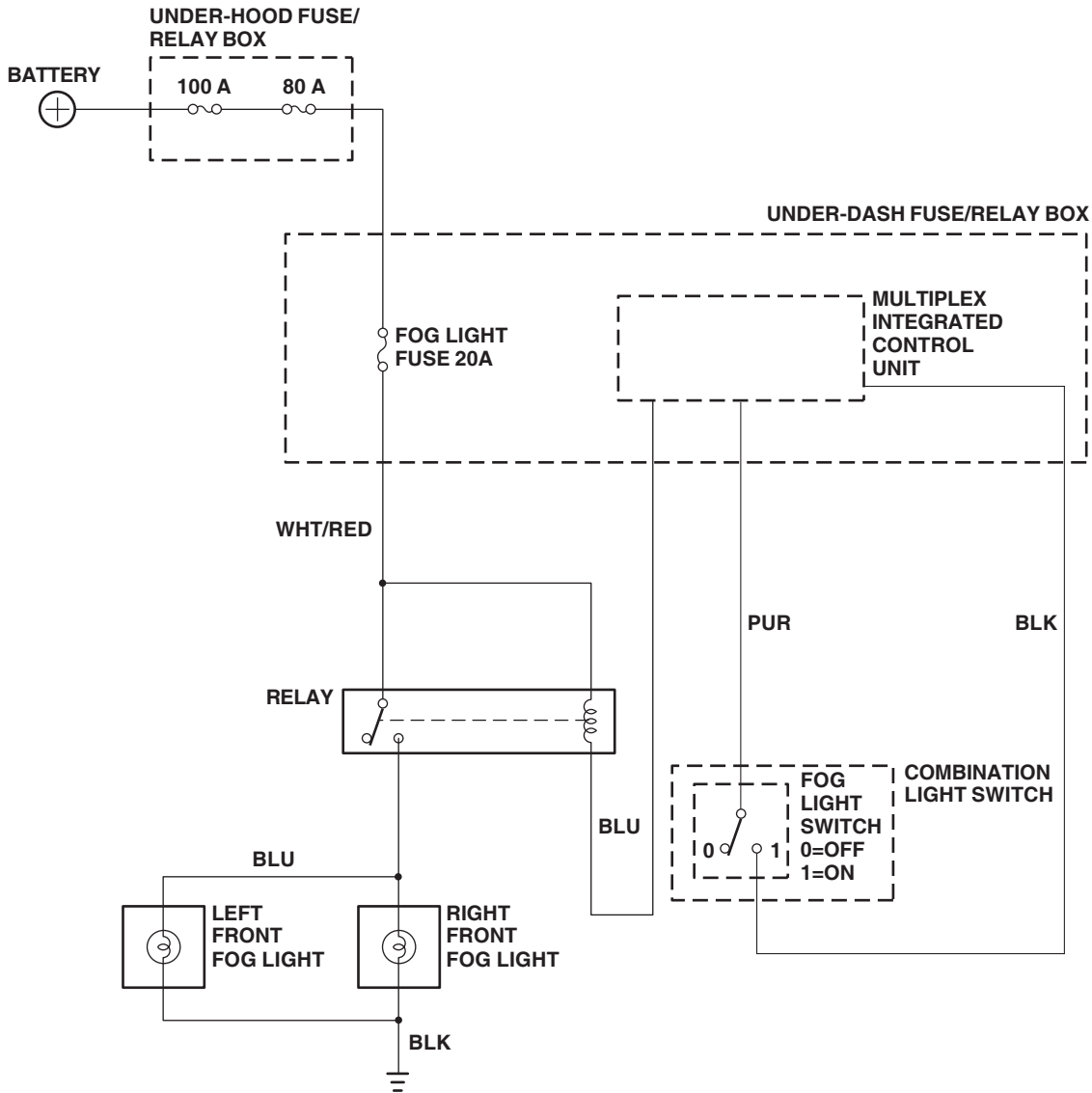

		HEADLIGHT SWITCH			
		OFF			
				Low	Hi
FOG LIGHT SWITCH	OFF	-	-	-	-
		-	-	ON	-

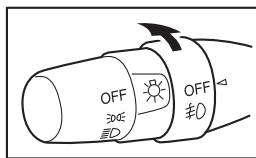

		HEADLIGHT SWITCH			
		OFF			
				Low	Hi
FOG LIGHT SWITCH	OFF	-	-	-	-
		-	-	ON	-

BLK	BLACK	BRN	BROWN
YEL	YELLOW	ORN	ORANGE
BLU	BLUE	PUR	PURPLE
GRN	GREEN	NAT	NATURAL
RED	RED	PNK	PINK
WHT	WHITE	GRY	GRAY
LT BLU	LIGHT BLUE	LT GRN	LIGHT GREEN