

PARTS LIST

Engine block heater

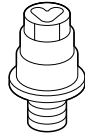

Aluminum washer



Heater harness

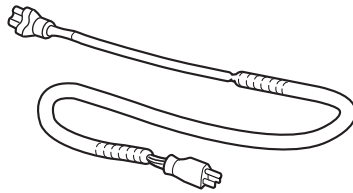

Protective cap

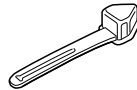
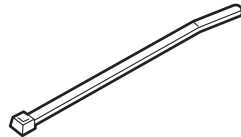
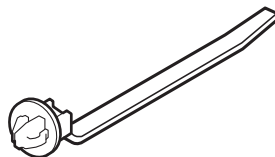
12 Black wire ties
(4 Not used)7 Wire ties with clip
(6 Not used)

5 White wire ties

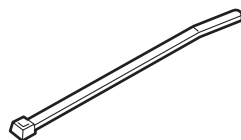
**TOOLS AND SUPPLIES REQUIRED**

Phillips screwdriver

Flat-tip screwdriver

Ratchet

8 mm, 10 mm, 19 mm, and 24 mm Sockets

Torque wrench

Diagonal cutters

Heavy gloves

Drain pan

Tape measure

Felt-tip pen

Coolant (Honda All Season Antifreeze/Coolant Type 2)

Eye protection (face shield, safety goggles, etc.)

Blanket

Drill

3 mm and 5 mm Drill bits

5 mm Hex wrench

Pushpin

Fender cover

Tape

File

Shop towel

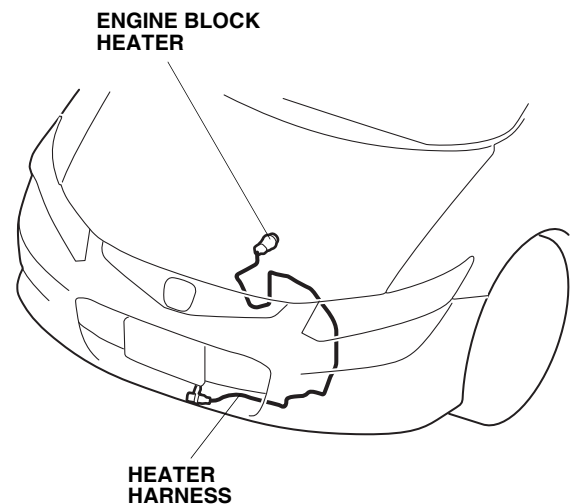
Illustration of the Engine Block Heater Installed on the Vehicle

INSTALLATION

Customer Information: The information in this installation instruction is intended for use only by skilled technicians who have the proper tools, equipment, and training to correctly and safely add equipment to your vehicle. These procedures should not be attempted by “do-it-yourselfers.”

NOTE:

- Always use Honda All Season Antifreeze/Coolant Type 2. Using a non-Honda coolant can result in corrosion, causing the cooling system to malfunction or fail.
 - To avoid burning out the element, do not operate the engine block heater until it is installed in the vehicle and you have added the coolant.
1. Disconnect the negative cable from the battery.
 2. Allow the engine and all cooling system components to cool down.
 3. Place a clean drain pan under the radiator drain plug, then remove the drain plug from the bottom of the radiator to drain the coolant. Remove the radiator cap to increase the flow.

NOTICE: Radiator coolant will damage the body paint. Quickly rinse any spilled coolant from body paint finish.

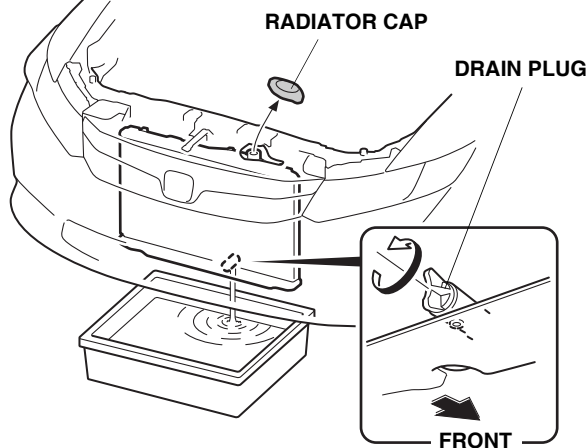

4. Drain the coolant completely, then reinstall the radiator cap.

5. Remove the front bumper:
 - Open the hood.
 - Wrap a shop towel around the hood latch.
 - On each side, attach tape to the areas shown.

HOOD LATCH
(Wrap with a shop towel.)

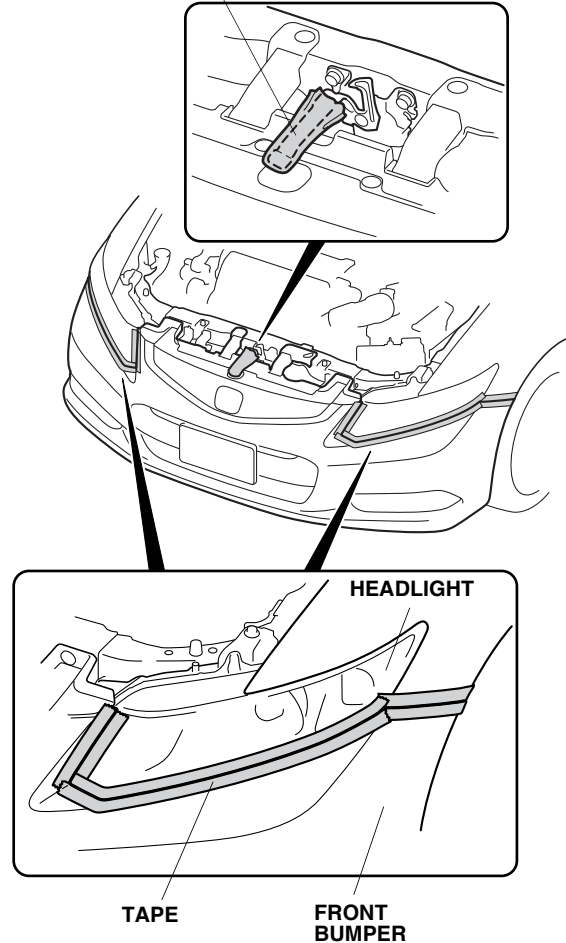

- Remove the 4 self-tapping screws, 10 short clips, and 2 long clips. Note the location of the long clips.

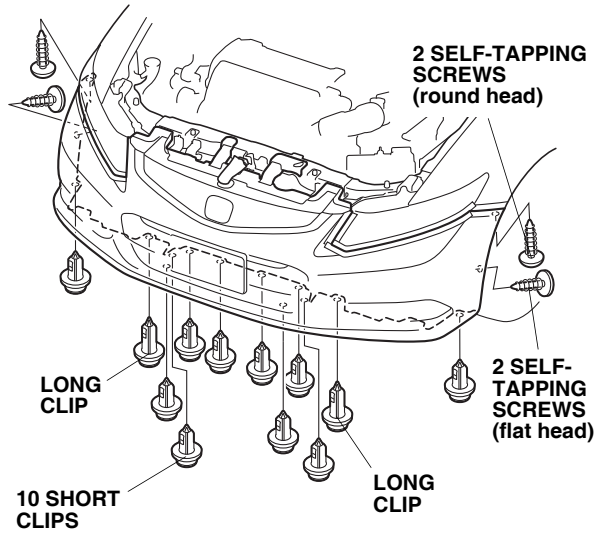

- On each side, release three retaining tabs.

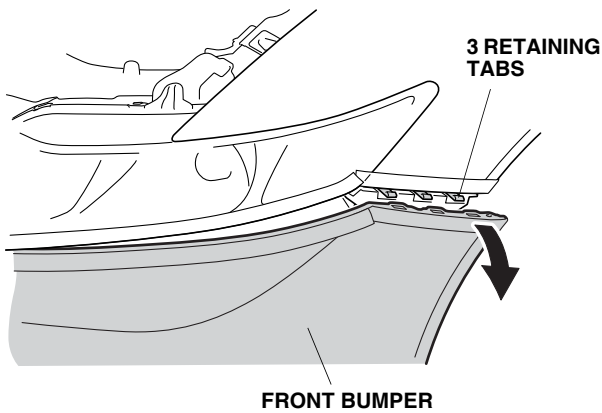

- On each side, release five retaining tabs.

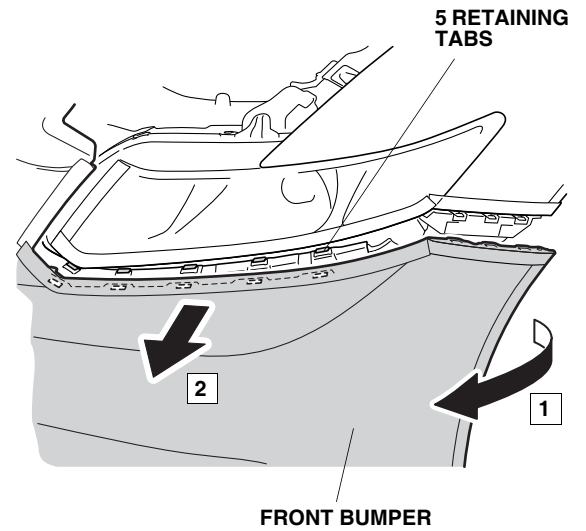

- With the help of an assistant, remove the front bumper (two hex bolts and two clips). Place the front bumper on a blanket to prevent damage.

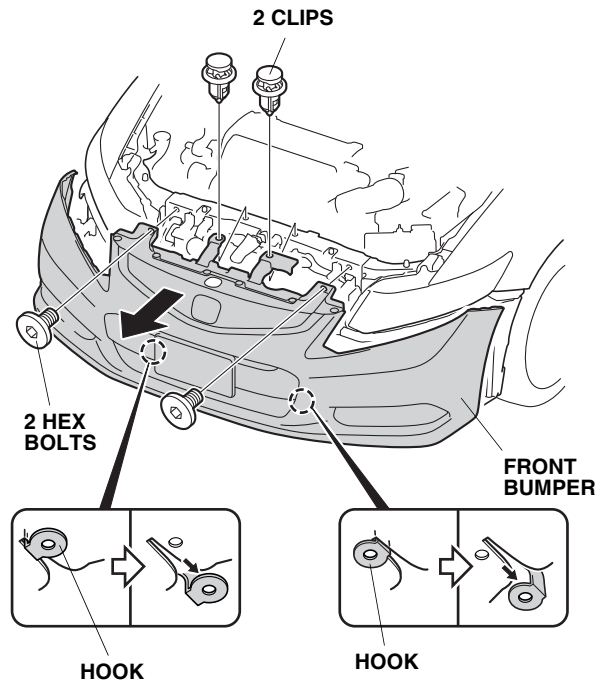

- Open the positive cable cover and disconnect the positive (+) battery cable from the battery.

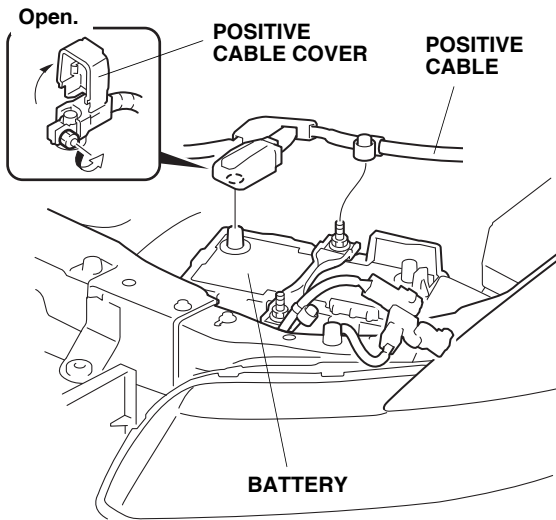

- Remove the two nuts from the battery setting plate, and remove the battery setting plate and J-bolts. Remove the battery upper cover, battery, and battery under cover.

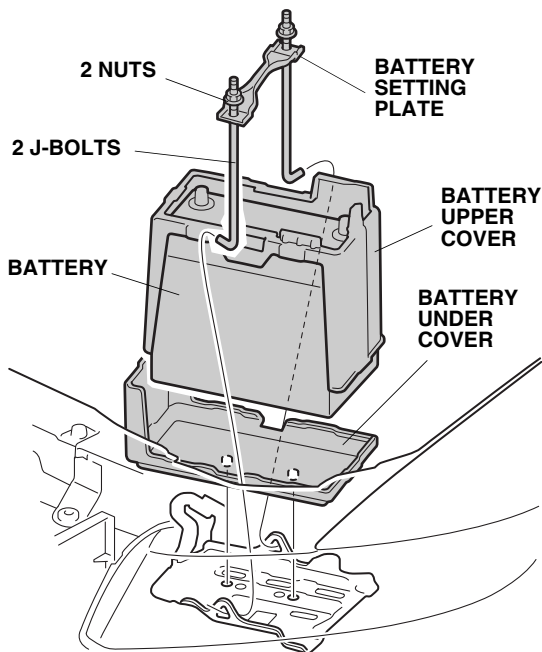

- Using a tape measure and a felt-tip pen, measure the heater harness and mark the heater harness at the three measurements shown.

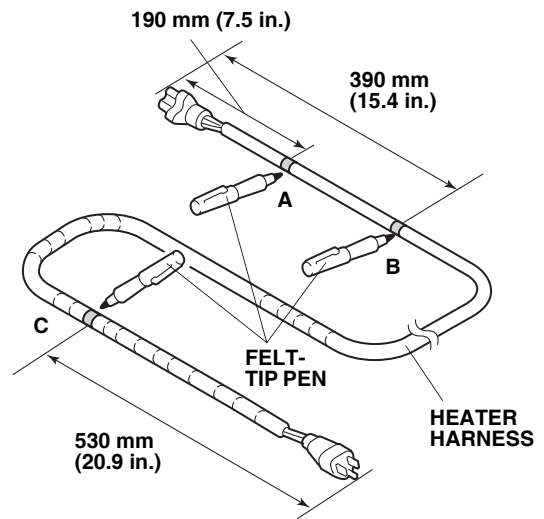

- Locate and remove the drain bolt and washer. Coolant remaining in the engine jackets flows out of the hole when the bolt is removed. Retain the bolt; it will be used if the block heater removed. NOTE: Use a new washer if the drain bolt is reinstalled.

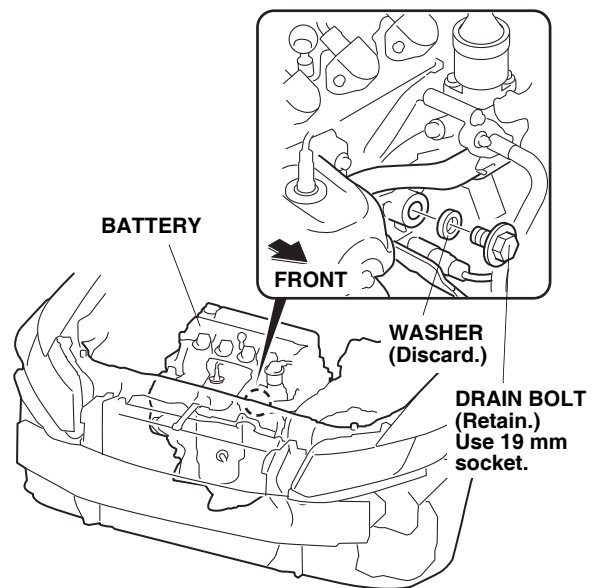

- Install the engine block heater with aluminum washer into the bolt hole using a 24 mm socket and a torque wrench. Torque the engine block heater to 60 N·m (44 lbf·ft).

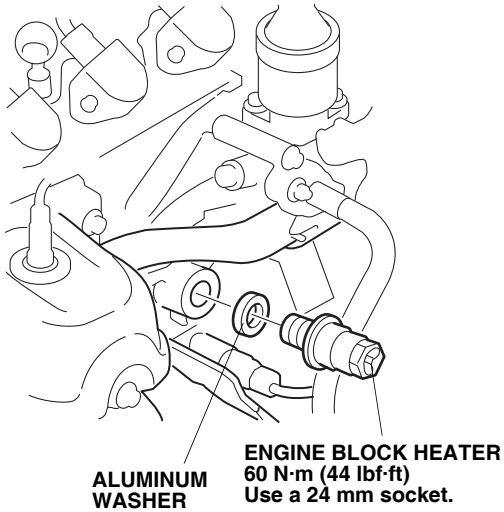

- Plug the connector end of the heater harness into the engine block heater.

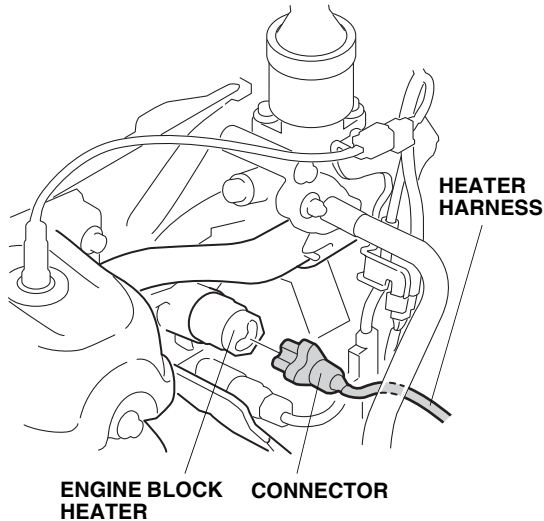

- Secure the heater harness to the vehicle bracket with one white wire tie at the mark you made at point A.

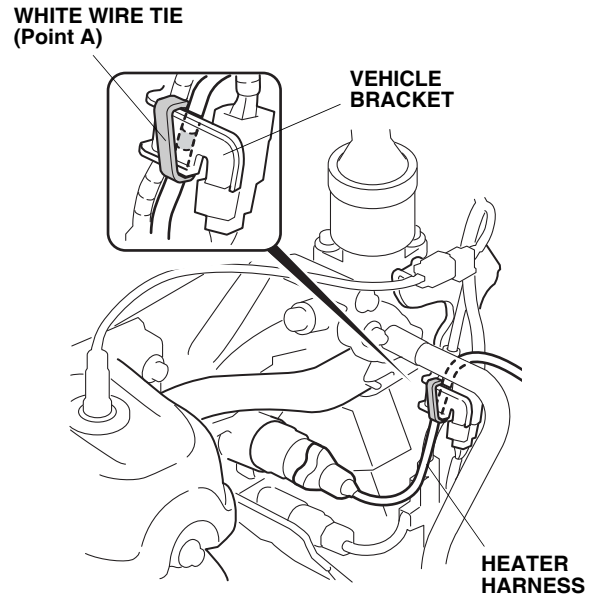

- Route the heater harness along the fan shroud as shown. Secure the heater harness to the fan shroud rib with one white wire tie at the mark you made at point B.

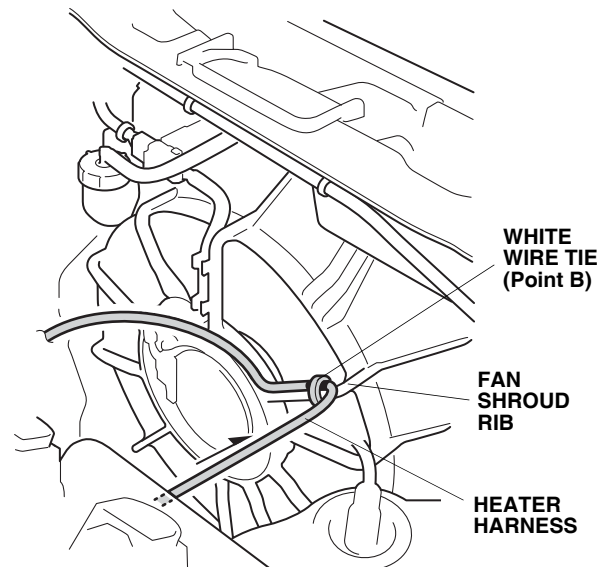

14. Route the heater harness up and toward the vehicle harness as shown.

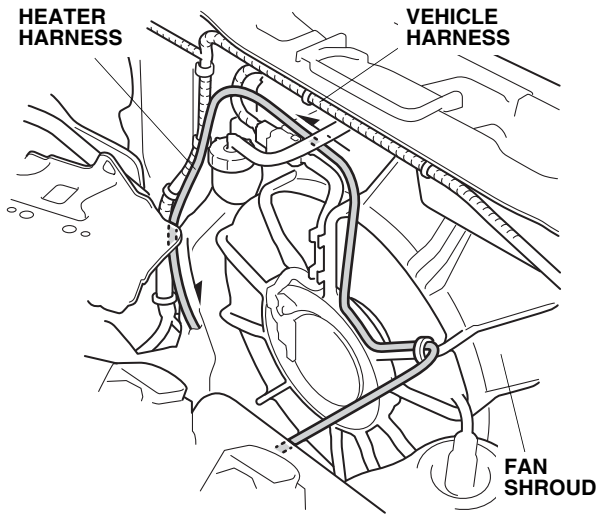

15. Using two black wire ties and three white wire ties, secure the heater harness to the fan shroud rib and vehicle harness.

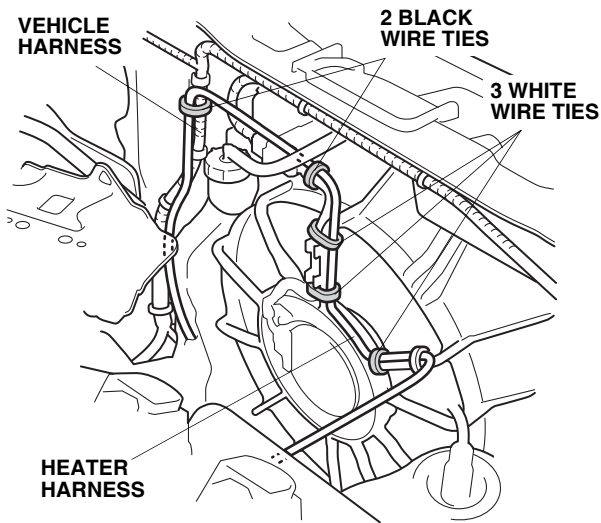

16. Route the heater harness down and under the vehicle frame as shown.

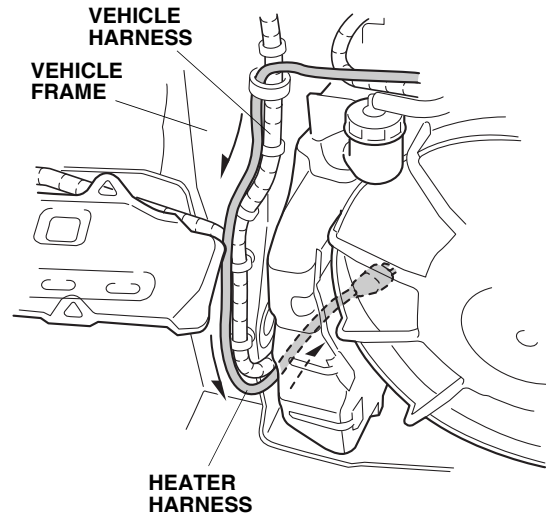

17. Using two black wire ties, secure the heater harness to the vehicle harness.

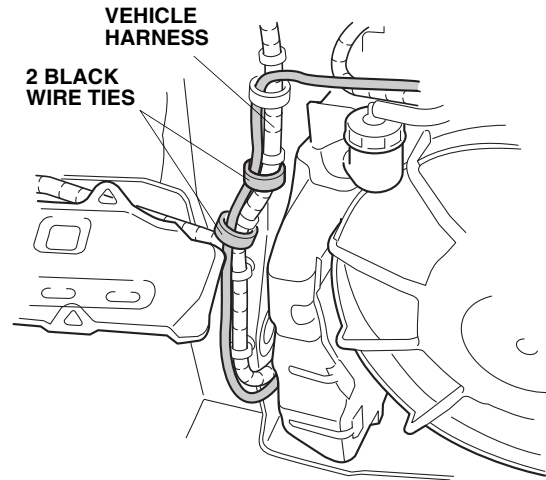

18. Route the heater harness through the front bulkhead as shown. Using one wire tie with clip, secure the heater harness to the vehicle frame.

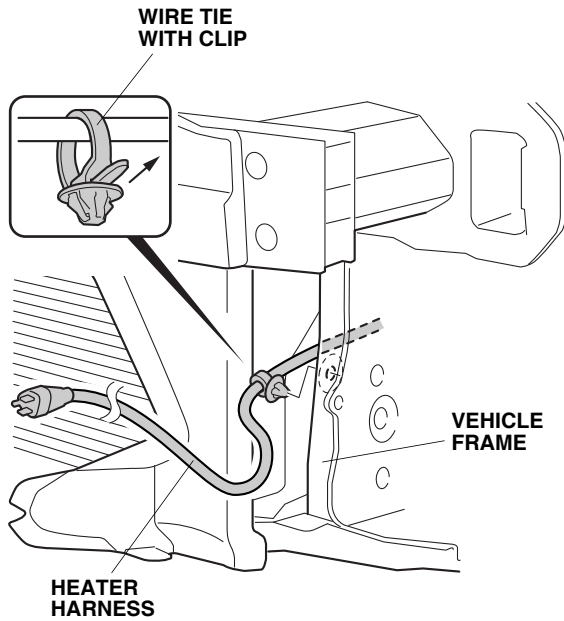

19. Using a felt-tip pen, mark the vehicle panel at the measurement shown.

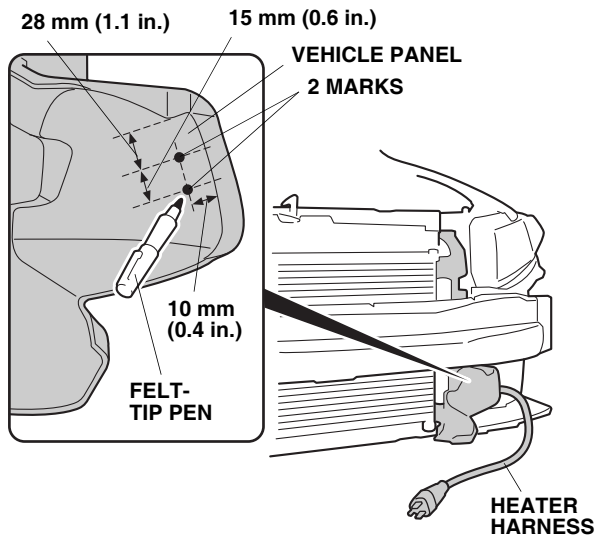

20. Using a pushpin, pierce the two marks on the vehicle panel. While wearing eye protection, drill the two pierced marks with a 3 mm drill bit, then enlarge the holes with a 5 mm drill bit. Remove any burrs.

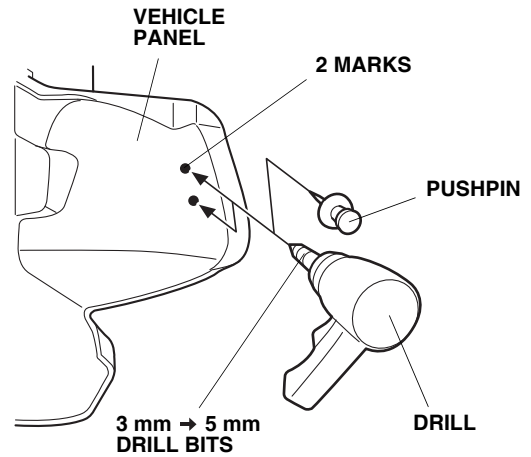

21. Secure the heater harness to the vehicle panel holes with one black wire tie at the mark you made at point C.

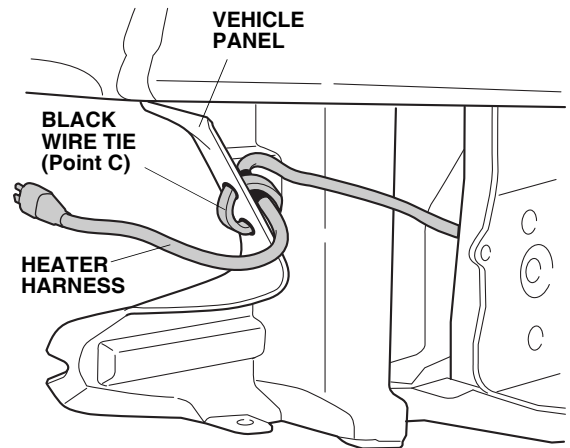

22. With the help of an assistant, route the heater harness through the grille opening in the bumper, then reinstall the front bumper with the help of an assistant.

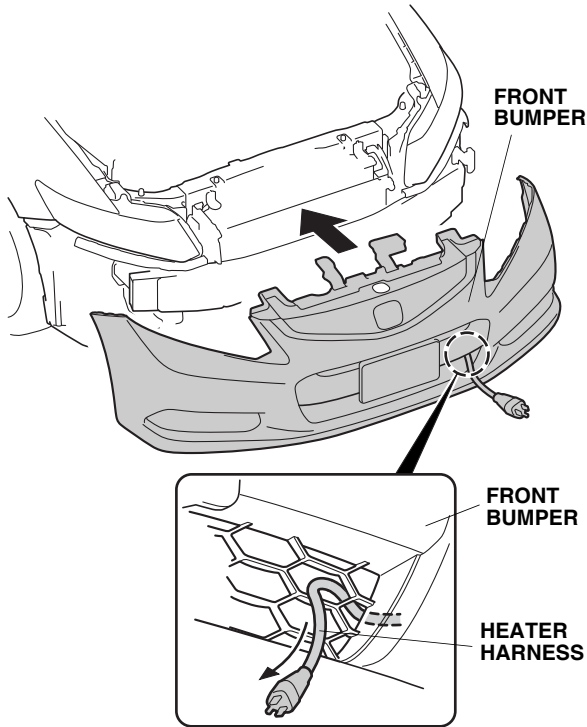

23. Using one black wire tie, secure the heater harness to the front bumper as shown.

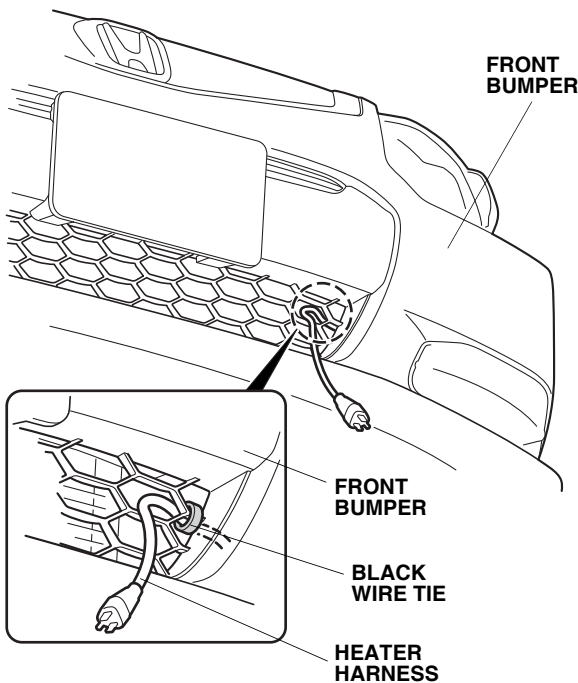

24. Route the heater harness inside the front bumper as shown.

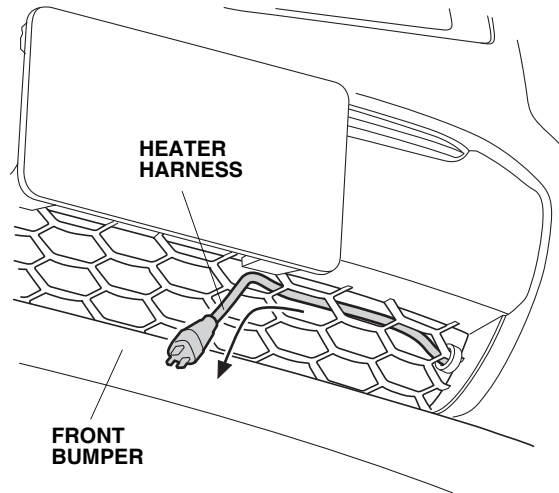

25. Using two black wire ties, secure the heater harness to the front grille as shown.

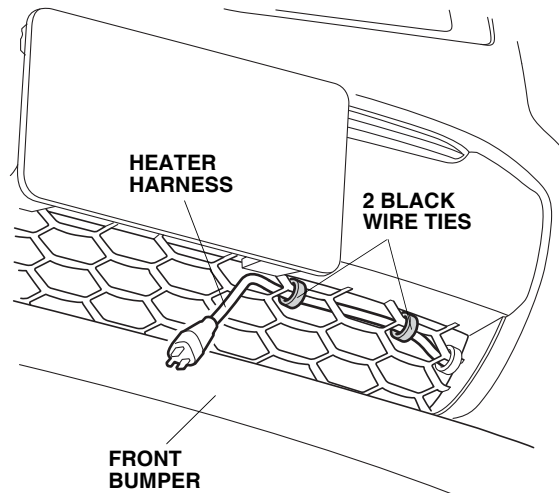

26. Attach the protective cap to the front grille, and plug the heater harness connector into the protective cap.

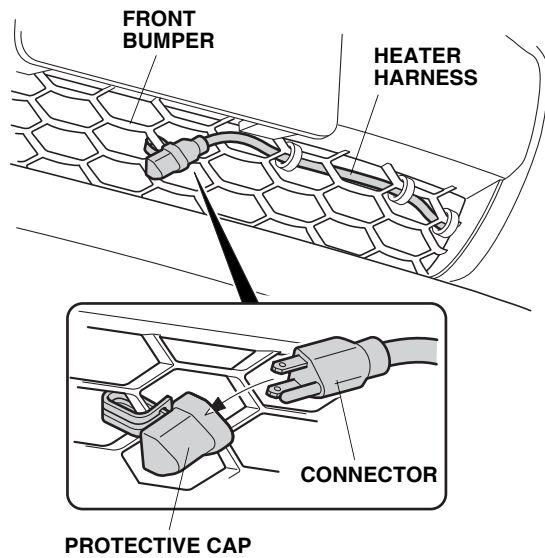

27. Reinstall all removed parts.
28. Reinstall the radiator drain plug.
29. Remove the radiator cap, and fill the system with the recommended coolant. Follow the instructions described in the Service Manual to fill and bleed the cooling system.
30. Check the coolant reservoir for correct level and check the cooling system for signs of leakage. Repair as necessary.
31. Check that the heater harness is routed properly and all connectors are plugged in.
32. Reinstall the radiator cap.
33. Put the drain bolt (removed in step 9) in the glove box.
34. Reconnect the negative cable to the battery.
35. Press and hold the radio power button for two seconds to restore radio and navigation (if equipped) system functions.
36. Reset the clock if necessary.